

ADJ. ALUMINUM GANTRY CRANE WITH DUAL TIRE PNEUMATIC CASTERS - AHA-4-8-10-PNU APPROX WEIGHT: 426.24 lbs. (DOES NOT INCLUDE WEIGHT OF POWER OR PACKAGING!!!)

*** ANY ADDITIONS, DELETIONS, OR OMISSIONS MUST BE CORRECTED ON THIS DRAWING AS THIS DRAWING WILL BE CONSIDERED ALL INCLUSIVE ***
 ALL GRAPHICS PROVIDED ARE FOR REFERENCE ONLY. IF CERTAIN DIMENSIONS ARE CRITICAL PLEASE VERIFY THOSE DIMENSIONS WITH YOUR SALESPERSON

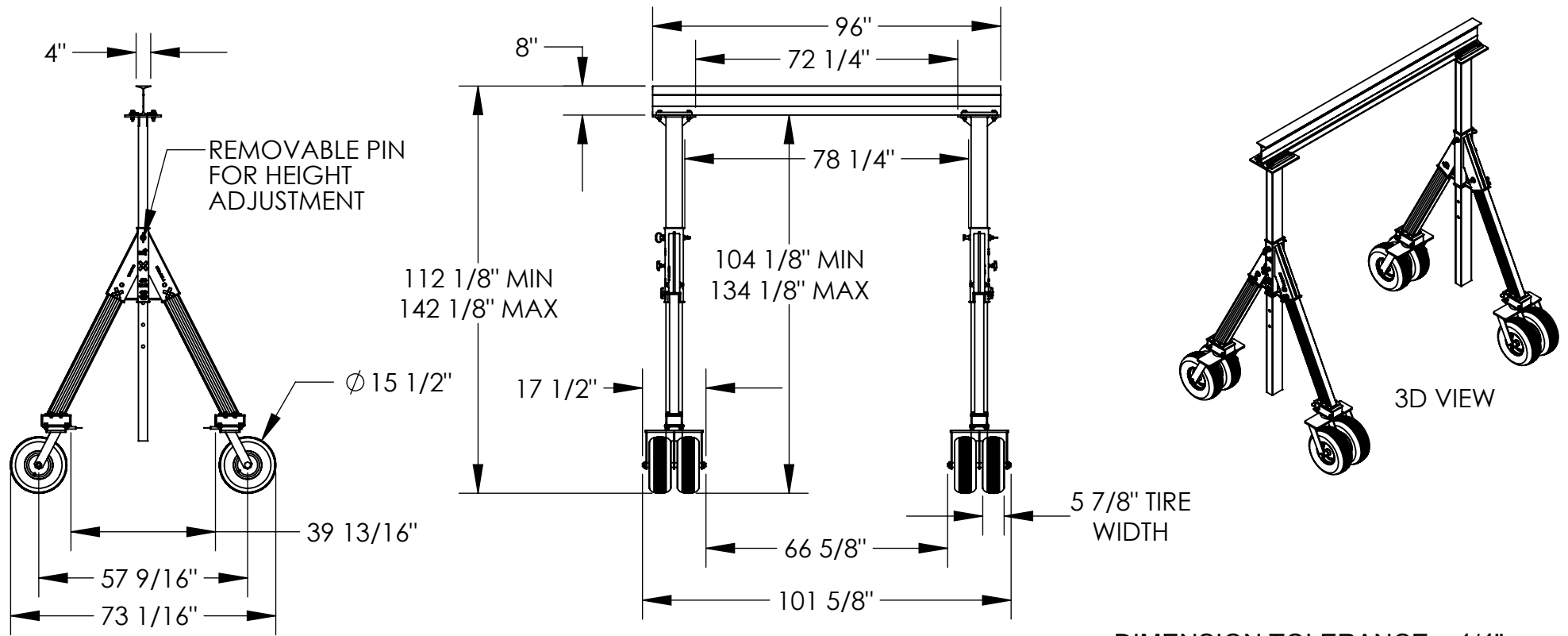

DIMENSION TOLERANCE ± 1/4"

STANDARD FEATURES

- MODEL NUMBER IS AHA-4-8-10-PNU
- CAPACITY IS 4,000 LBS.
- BASE WIDTH IS 73 1/16"
- MAX OVERALL HEIGHT IS 142 1/8"
- I-BEAM HEIGHT IS 8"
- I-BEAM WIDTH IS 4"
- OVERALL I-BEAM LENGTH IS 96"
- USABLE I-BEAM LENGTH IS 72 1/4"
- ADJUSTABLE UNDER I-BEAM HEIGHT
 - 104 1/8" MIN
 - 134 1/8" MAX
- HEIGHT IS ADJUSTABLE IN 6" INCREMENTS
- (4) Ø 15 1/2" DUAL TIRE PNEUMATIC CASTERS
(SWIVEL WITH (4) LOCKING POSITIONS)
- PNU MODELS ARE 12" TALLER THAN STANDARD
- AHA UNITS OF THE SAME HEIGHT DESIGNATION
- ALUMINUM CONSTRUCTION

SPECIAL FEATURES

NONE

A P P R O V A L	I, THE UNDERSIGNED, AGREE THAT THE PRODUCT AS REPRESENTED SATISFIES DESIGN AND DIMENSION REQUIREMENTS. I ALSO ACKNOWLEDGE MY DUTY TO CONFIRM PRODUCT AND INSTALLATION COMPLIANCE WITH ALL APPLICABLE FEDERAL, STATE AND LOCAL REGULATIONS AND STANDARDS.	
	UNITS REQUIRING APPROVAL DRAWINGS OR MODIFIED ARE NON-RETURNABLE	
	[] As drawn [] As marked	
	Signed: _____ Date: _____	
Printed Name: _____		
<i>LEAD TIME WILL START UPON RECEIPT OF SIGNED APPROVAL DRAWING</i>		

DISTRIBUTOR'S NAME:		P.O.#
VESTIL MANUFACTURING		X
DRAWN BY: MTS		W.O.#
DATE: 01/29/2021		X
REFERENCE: X		SALES: X
SCALE: 1:42		FILE NAME:
QUOTED LEAD TIME: X		28-007-469
QUOTE #		
X		