

# ADJ. ALUMINUM GANTRY CRANE WITH DUAL TIRE PNEUMATIC CASTERS - AHA-4-12-8-PNU

APPROX WEIGHT: 462.34 lbs.  
(DOES NOT INCLUDE WEIGHT OF POWER OR PACKAGING!!!)

\*\*\* ANY ADDITIONS, DELETIONS, OR OMISSIONS MUST BE CORRECTED ON THIS DRAWING AS THIS DRAWING WILL BE CONSIDERED ALL INCLUSIVE \*\*\*  
ALL GRAPHICS PROVIDED ARE FOR REFERENCE ONLY. IF CERTAIN DIMENSIONS ARE CRITICAL PLEASE VERIFY THOSE DIMENSIONS WITH YOUR SALESPERSON

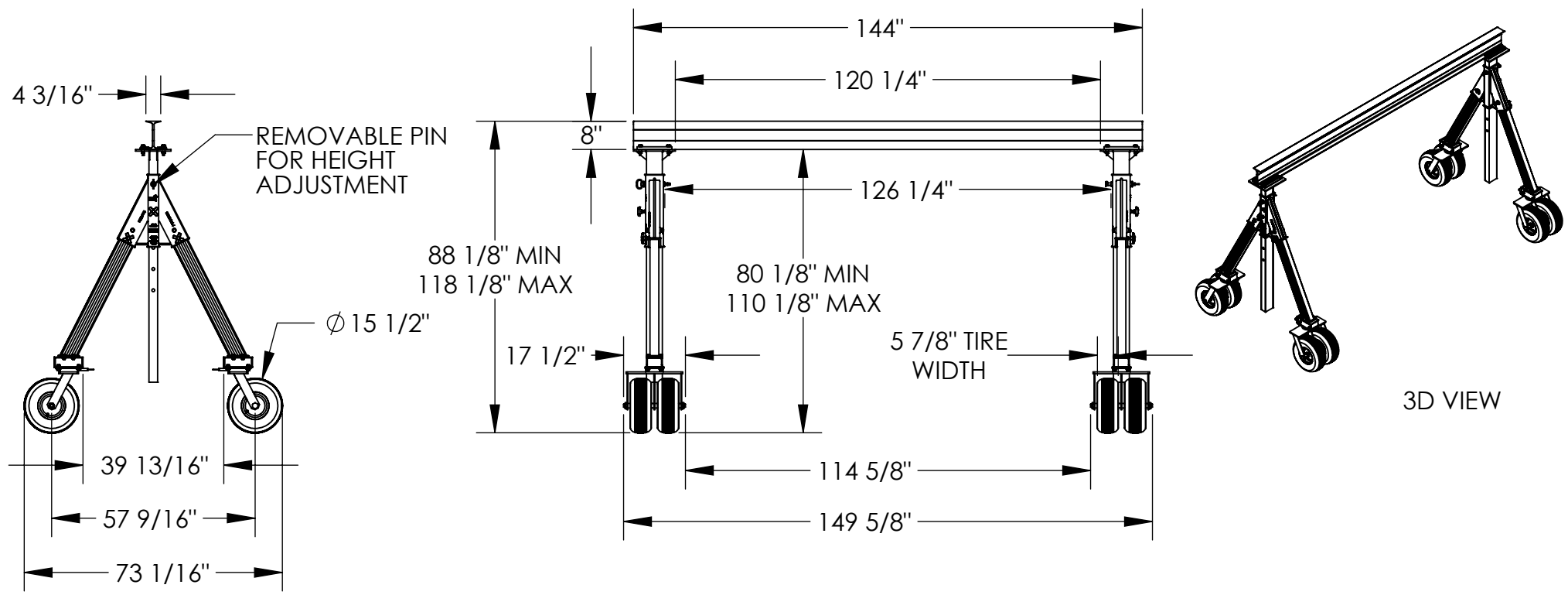

DIMENSION TOLERANCE ± 1/4"

## STANDARD FEATURES

- MODEL NUMBER IS AHA-4-12-8-PNU
- CAPACITY IS 4,000 LBS.
- BASE WIDTH IS 73 1/16"
- MAX OVERALL HEIGHT IS 118 1/8"
- I-BEAM HEIGHT IS 8"
- I-BEAM WIDTH IS 4 3/16"
- OVERALL I-BEAM LENGTH IS 144"
- USABLE I-BEAM LENGTH IS 120 1/4"
- ADJUSTABLE UNDER I-BEAM HEIGHT
  - 80 1/8" MIN
  - 110 1/8" MAX
- HEIGHT IS ADJUSTABLE IN 6" INCREMENTS
- (4) Ø 15 1/2" DUAL TIRE PNEUMATIC CASTERS (SWIVEL WITH (4) LOCKING POSITIONS)
- PNU MODELS ARE 12" TALLER THAN STANDARD
- AHA UNITS OF THE SAME HEIGHT DESIGNATION
- ALUMINUM CONSTRUCTION

## SPECIAL FEATURES

NONE

<b>APPROVAL</b>	I, THE UNDERSIGNED, AGREE THAT THE PRODUCT AS REPRESENTED SATISFIES DESIGN AND DIMENSION REQUIREMENTS. I ALSO ACKNOWLEDGE MY DUTY TO CONFIRM PRODUCT AND INSTALLATION COMPLIANCE WITH ALL APPLICABLE FEDERAL, STATE AND LOCAL REGULATIONS AND STANDARDS.	
	<b>UNITS REQUIRING APPROVAL DRAWINGS OR MODIFIED ARE NON-RETURNABLE</b>	
	[ ] As drawn      [ ] As marked	
	Signed: _____	Date: _____
Printed Name: _____		
<b>LEAD TIME WILL START UPON RECEIPT OF SIGNED APPROVAL DRAWING</b>		

DISTRIBUTOR'S NAME:		P.O.#
<b>VESTIL MANUFACTURING</b>		X
		W.O.#
DRAWN BY: MTS	DATE: 01/29/2021	X
REFERENCE: X	SCALE: 1:42	FILE NAME:
QUOTED LEAD TIME: X	QUOTE # X	28-007-465