

# ADJ. ALUMINUM GANTRY CRANE WITH DUAL TIRE PNEUMATIC CASTERS - AHA-4-12-10-PNU

APPROX WEIGHT: 474.59 lbs.  
(DOES NOT INCLUDE WEIGHT OF POWER OR PACKAGING!!!)

\*\*\* ANY ADDITIONS, DELETIONS, OR OMISSIONS MUST BE CORRECTED ON THIS DRAWING AS THIS DRAWING WILL BE CONSIDERED ALL INCLUSIVE \*\*\*  
ALL GRAPHICS PROVIDED ARE FOR REFERENCE ONLY. IF CERTAIN DIMENSIONS ARE CRITICAL PLEASE VERIFY THOSE DIMENSIONS WITH YOUR SALESPERSON

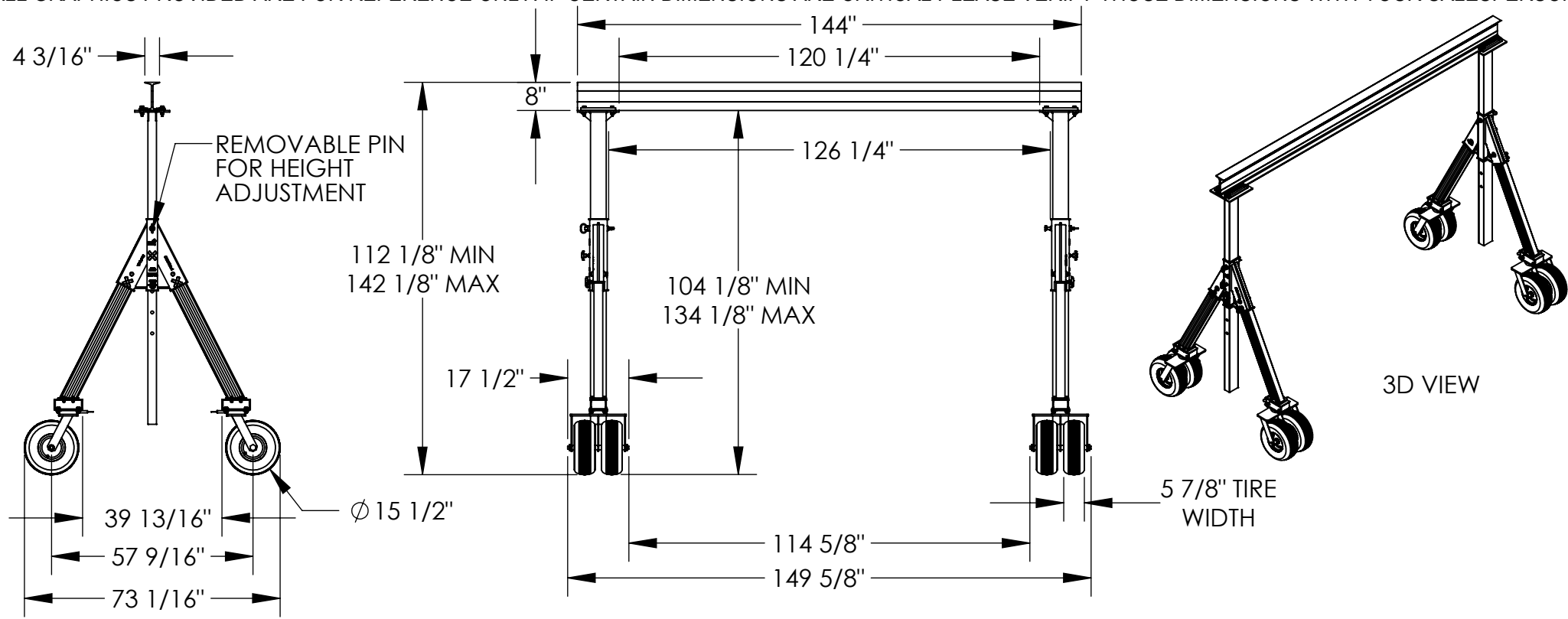

DIMENSION TOLERANCE ± 1/4"

## STANDARD FEATURES

- MODEL NUMBER IS AHA-4-12-10-PNU
- CAPACITY IS 4,000 LBS.
- BASE WIDTH IS 73 1/16"
- MAX OVERALL HEIGHT IS 142 1/8"
- I-BEAM HEIGHT IS 8"
- I-BEAM WIDTH IS 4 3/16"
- OVERALL I-BEAM LENGTH IS 144"
- USABLE I-BEAM LENGTH IS 120 1/4"
- ADJUSTABLE UNDER I-BEAM HEIGHT
  - 104 1/8" MIN
  - 134 1/8" MAX
- HEIGHT IS ADJUSTABLE IN 6" INCREMENTS
- (4) Ø 15 1/2" DUAL TIRE PNEUMATIC CASTERS (SWIVEL WITH (4) LOCKING POSITIONS)
- PNU MODELS ARE 12" TALLER THAN STANDARD
- AHA UNITS OF THE SAME HEIGHT DESIGNATION
- ALUMINUM CONSTRUCTION

## SPECIAL FEATURES

NONE

APPROVAL

I, THE UNDERSIGNED, AGREE THAT THE PRODUCT AS REPRESENTED SATISFIES DESIGN AND DIMENSION REQUIREMENTS. I ALSO ACKNOWLEDGE MY DUTY TO CONFIRM PRODUCT AND INSTALLATION COMPLIANCE WITH ALL APPLICABLE FEDERAL, STATE AND LOCAL REGULATIONS AND STANDARDS.  
**UNITS REQUIRING APPROVAL DRAWINGS OR MODIFIED ARE NON-RETURNABLE**  
[ ] As drawn [ ] As marked

Signed: \_\_\_\_\_ Date: \_\_\_\_\_

Printed Name: \_\_\_\_\_

LEAD TIME WILL START UPON RECEIPT OF SIGNED APPROVAL DRAWING

DISTRIBUTOR'S NAME:		P.O.#
VESTIL MANUFACTURING		X
DRAWN BY: MTS		W.O.#
DATE: 01/29/2021		X
REFERENCE: X	SCALE: 1:42	SALES: X
QUOTED LEAD TIME: X	QUOTE #	FILE NAME:
	X	28-007-463