

ADJUSTABLE ALUMINUM GANTRY CRANE -AHA-15-12-12-PNU APPROX WEIGHT: 317 lbs. DOES NOT INCLUDE WEIGHT OF POWER OR PACKAGING!!!

*** ANY ADDITIONS, DELETIONS, OR OMISSIONS MUST BE CORRECTED ON THIS DRAWING AS THIS DRAWING WILL BE CONSIDERED ALL INCLUSIVE ***
 ALL GRAPHICS PROVIDED ARE FOR REFERENCE ONLY. IF CERTAIN DIMENSIONS ARE CRITICAL PLEASE VERIFY THOSE DIMENSIONS WITH YOUR SALESPERSON

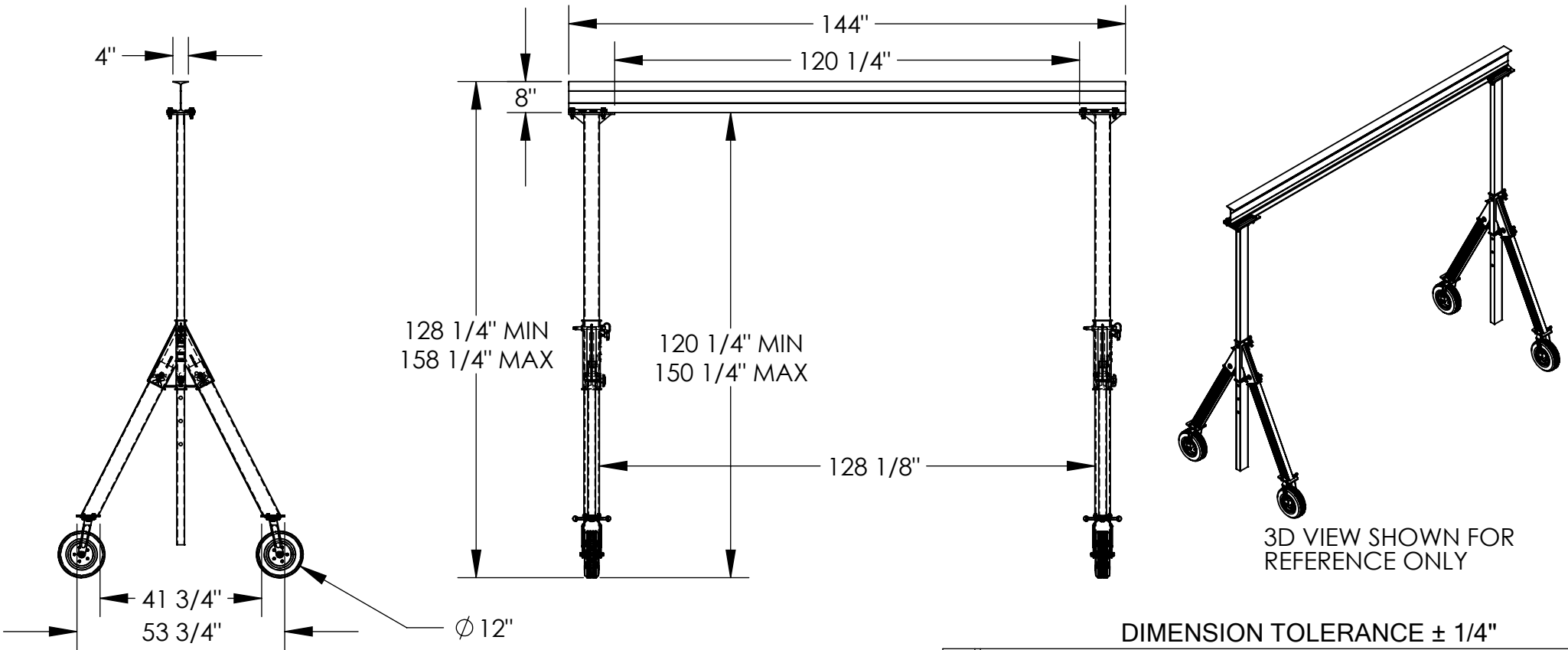

STANDARD FEATURES

- MODEL NUMBER IS AHA-15-12-12-PNU
- CAPACITY IS 1,500 LBS.
- BASE WIDTH IS 53 3/4"
- MAX OVERALL HEIGHT IS 158 1/4"
- I-BEAM HEIGHT IS 8"
- I-BEAM FLANGE WIDTH IS 4"
- OVERALL I-BEAM LENGTH IS 144"
- USABLE I-BEAM LENGTH IS 120 1/4"
- ADJUSTABLE UNDER I-BEAM HEIGHT
 - 120 1/4" MIN
 - 150 1/4" MAX
- HEIGHT IS ADJUSTABLE IN 6" INCREMENTS
- CASTERS: (4) Ø12" X 3 1/2" WIDE
 - PNEUMATIC SWIVEL CASTERS WITH
 - FOUR LOCKING POSITIONS
 - ALUMINUM CONSTRUCTION

SPECIAL FEATURES

NONE

DIMENSION TOLERANCE ± 1/4"

A P P R O V A L	I, THE UNDERSIGNED, AGREE THAT THE PRODUCT AS REPRESENTED SATISFIES DESIGN AND DIMENSION REQUIREMENTS. I ALSO ACKNOWLEDGE MY DUTY TO CONFIRM PRODUCT AND INSTALLATION COMPLIANCE WITH ALL APPLICABLE FEDERAL, STATE AND LOCAL REGULATIONS AND STANDARDS.	
	UNITS REQUIRING APPROVAL DRAWINGS OR MODIFIED ARE NON-RETURNABLE	
	[] As drawn [] As marked	
	Signed: _____ Date: _____	
Printed Name: _____		
LEAD TIME WILL START UPON RECEIPT OF SIGNED APPROVAL DRAWING		

FOR INTERNAL USE ONLY PROJECT SIGN OFF	
SALES	
ENG.	
FAB.	
POWER	

DISTRIBUTOR'S NAME:		P.O.#
VESTIL MANUFACTURING		X
DRAWN BY: ND	DATE: 07/11/13	W.O.#
REFERENCE: X	SCALE: 1:38	SALES: X
QUOTED LEAD TIME: X	QUOTE # X	FILE NAME:
		28-007-293