



by Stevens Industries, Inc.
 704 West Main St.
 Teutopolis, IL 62467
 P: 800.350.3270
 P: 217-857-7100 • F: 217-857-7101
 www.totmate.com

TMS401R TM2306R

ATTENTION

Please unpack and assemble in an area away from children's activities. Remove all tools and excess materials from work area after assembly of unit is complete. Dispose of pallet and packaging materials in an environmentally friendly manner. If any parts are missing or damaged, please call Stevens for immediate parts replacement (1-800-350-3270). When ordering parts, give the Model Number and Color of the unit.



CAUTION – CHOKING HAZARD

Adult assembly required due to presence of small parts and sharp edges.

NOTE: ASSEMBLY INSTRUCTIONS REFERENCE ILLUSTRATIONS AND PART NUMBERS FOR THE TM2306R.



TMS401R
 School Age Shelf Storage

		Parts List	
ITEM	QTY	PART #	DESCRIPTION
1	1	71XX-0672	Back
2	2	41XX-1473	End U
3	2	51XX-1306	Top-Bot
4	2	51XX-1307	Shelf
5	12	0861-0203000000	Screw Conn HxDc Ni 7mmx 50mm
6	2	0861-0445000000	Screw Tapp PhWh Zinc #8 X 1.25

NOTE: Hardware bag includes (4) 0861-0445000000 Screw Tapp PhWh Zinc #8x1.25, but ONLY TWO are to be used with the TMS401R.



TM2306R
 School Age Shelf Storage

		Parts List	
ITEM	QTY	PART #	DESCRIPTION
1	2	51XX-1271	Top
2	2	41XX-1473	End U
3	1	71XX-0642	Back
4	2	51XX-1272	Shelf
5	4	0861-0445000000	Screw Tapp PhWh Zinc #8 X 1.25
6	12	0861-0203000000	Screw Conn HxDc Ni 7mmx 50mm



TMS401R – TM2306R

STEP-BY-STEP ASSEMBLY

ILLUSTRATIONS AND PART NUMBERS ARE FOR TM2306R. BASIC ASSEMBLY INSTRUCTIONS ARE THE SAME FOR BOTH MODELS. 2-PERSON ASSEMBLY RECOMMENDED.

IMPORTANT!

Be sure to keep all parts supported during assembly to avoid damage. Do not over-tighten screws or it will damage the pre-drilled holes; snug fit is adequate.

HARDWARE / TOOLS INCLUDED

(Phillips screwdriver required but not included.)

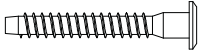

Confirmat Bolt (6)
(Screw Conn HxDc Ni 7mmx50mm)

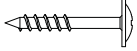

Back Screw (5)
(Screw Tapp PhWh Zinc #8x1.25)



Hex Wrench

(4) Back Screws are included in the TMS401R hardware bag, but ONLY TWO are to be used with the TMS401R.

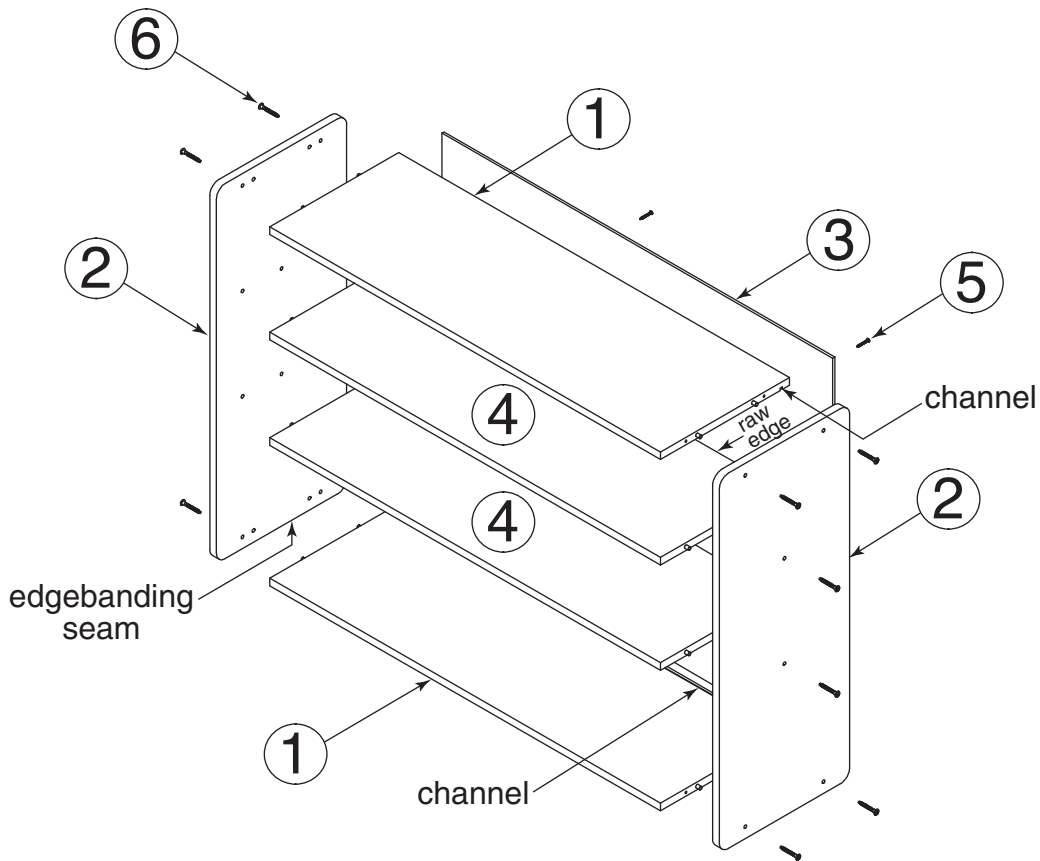

TM2306R Parts List			
ITEM	QTY	PART #	DESCRIPTION
1	2	51XX-1271	Top
2	2	41XX-1473	End U
3	1	71XX-0642	Back
4	2	51XX-1272	Shelf
5	4	0861-0445000000	Screw Tapp PhWh Zinc #8 X 1.25
6	12	0861-0203000000	Screw Conn HxDc Ni 7mmx 50mm



STEP-BY-STEP ASSEMBLY

STEP 1

Identify **Tops (1)**. Note that routed channels along back edges of **Tops (1)** will face interior of unit for installation of **Back (3)**.

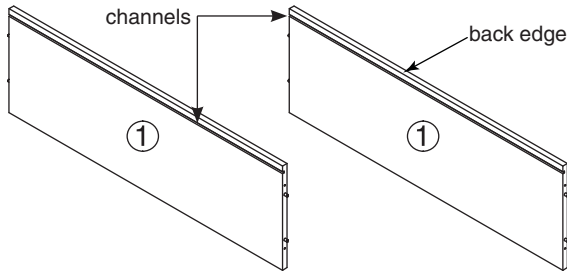

STEP 2

With **End (2)** resting on its front edge, insert dowels on one **Top (1)** into holes on **End (2)**. Make sure back edge of **Top (1)** is facing up and channel is facing toward interior of unit. Press firmly into place. Secure **Top (1)** to **End (2)** with two **Confirmat Bolts (6)**.

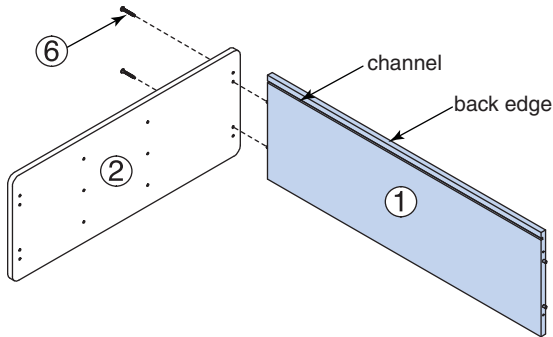

STEP 3

Repeat **Step 2** with other **Top (1)**. Make sure channel is facing toward interior of unit and channels on both **Tops (1)** are aligned.

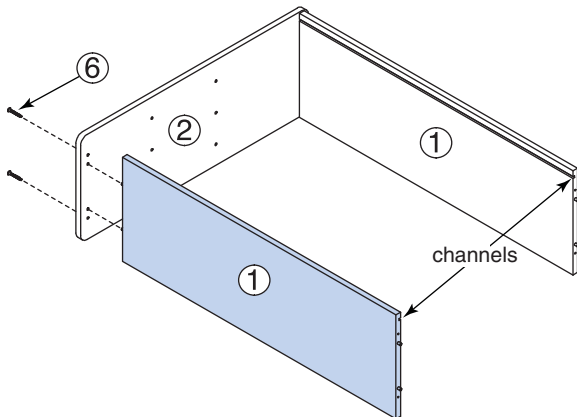

STEP 4

Insert dowels on **Shelves (4)** into remaining holes on **End (2)**. Make sure raw edges are facing up (toward back of unit). Press firmly into place. Secure **Shelves (4)** to **End (2)** with two **Confirmat Bolts (6)**.

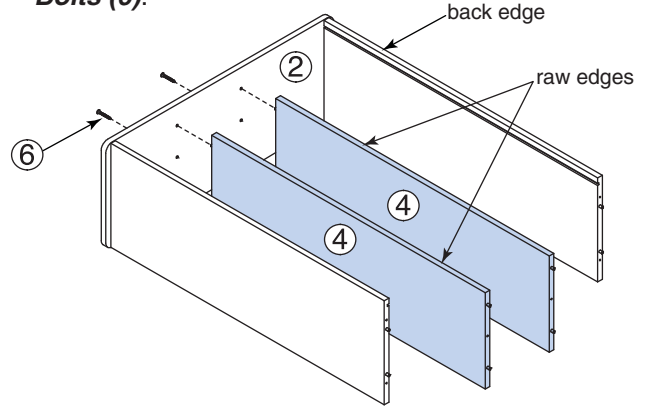

STEP 5

Slide **Back (3)** into channels on **Tops (1)**. Make sure pre-drilled holes on **Back (3)** align with edges of **Shelves (4)**. If they do not align, remove **Back (3)**, rotate 180°, reinsert and check alignment. Seat firmly against **End (2)**.

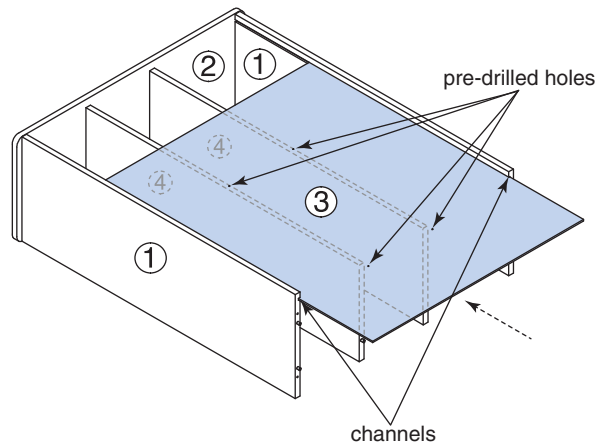



TMS401R – TM2306R

STEP-BY-STEP ASSEMBLY

STEP 6

Position other **End (2)** at opposite end of unit, so dowels on **Tops (1)** and **Shelves (4)** align with holes on **End (2)**. Press firmly into place. **HINT: Propping up Tops and Shelves will allow End to be positioned without obstruction.**

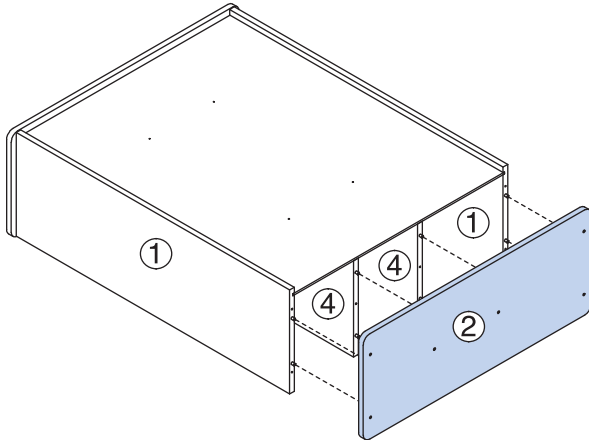

STEP 7

Secure **End (2)** to **Tops (1)** and **Shelves (4)** with six **Confirmat Bolts (6)**.

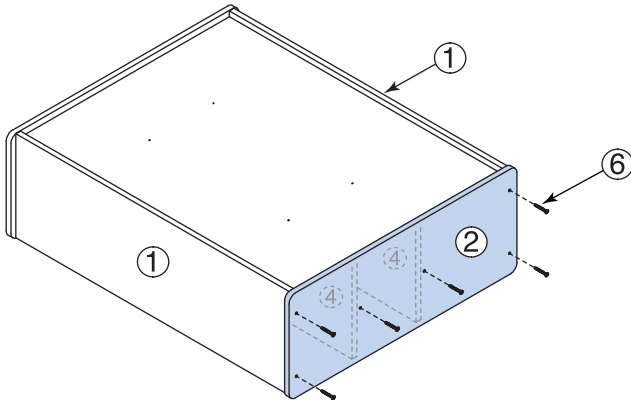

STEP 8

Secure **Back (3)** to **Shelves (4)** with four **Back Screws (5)**. (Phillips screwdriver not included.) **NOTE: TMS401R only requires two back screws (one per shelf). IMPORTANT! Make sure Back Screws are centered on edge of Shelves and inserted straight into Shelves. This is necessary to prevent Back Screws from protruding through and damaging Shelf surfaces.**

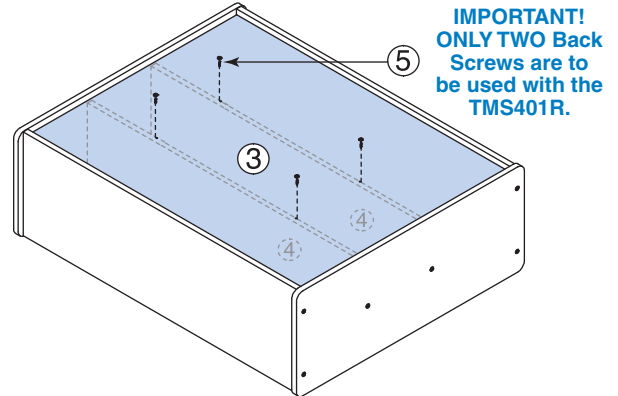

STEP 9

Carefully stand unit upright. Make sure edgebanding seams on **Ends (2)** are on bottom of unit.

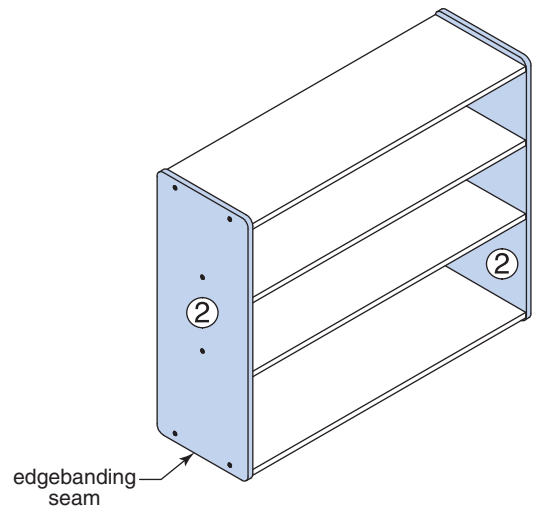

STEP 10

Ensure that all joints, bolts and screws are tight.

This completes the assembly.