



by Stevens Industries, Inc.
 704 West Main St.
 Teutopolis, IL 62467
 P: 800.350.3270
 P: 217-857-7100 • F: 217-857-7101
 www.totmate.com

TM8350R TM8352R

ATTENTION

Please unpack and assemble in an area away from children's activities. Remove all tools and excess materials from work area after assembly of unit is complete. Dispose of pallet and packaging materials in an environmentally friendly manner. If any parts are missing or damaged, please call Stevens for immediate parts replacement (1-800-350-3270). When ordering parts, give the Model Number and Color of the unit.



CAUTION – CHOKING HAZARD

Adult assembly required due to presence of small parts and sharp edges.

IMPORTANT!

Assembly must be securely attached to building structure with anchoring devices of appropriate type, size and quantity in accordance with applicable codes and accepted installation practices.

NOTE: ASSEMBLY INSTRUCTIONS REFERENCE ILLUSTRATIONS AND PART NUMBERS FOR THE TM8352R.



**TM8350R
 Single Floor Vanity**

			Parts List	
ITEM	QTY	PART #	DESCRIPTION	
1	2	41XX-1501	End U	
2	1	82XX-0252	Access Panel	
3	4	61XX-0640	Rail-TK-Supt	
4	4	0861-0338000000	Nut Propell 1/4 20x.5 5/8Flang	
5	4	0861-0032000000	Screw Mach PhTr Zn 1/4-20x1.50	
6	8	0861-0203000000	Screw Conn HxDc Ni 7mmx 50mm	
7	1	0661-1259000000	Fauc PEER P241LF Lav 4"	
8	1	0660-2708000000	Sink Sng CDE3122SPW 21x31 Wht	
9	1	0661-0008000000	Plbg Strainer Flat D70-100	



**TM8352R
 Double Floor Vanity**

			Parts List	
ITEM	QTY	PART #	DESCRIPTION	
1	2	41XX-1501	End U	
2	1	82XX-0253	Access Panel	
3	4	61XX-0641	Rail-TK-Supt	
4	2	61XX-0649	Rail-Xsupt	
5	4	0861-0338000000	Nut Propell 1/4 20x.5 5/8Flang	
6	4	0861-0032000000	Screw Mach PhTr Zn 1/4-20x1.50	
7	1	0660-2709000000	Sink Dbl DDE4922SPW 21x49 Wht	
8	2	0661-1259000000	Fauc PEER P241LF Lav 4"	
9	2	0661-0008000000	Plbg Strainer Flat D70-100	
10	8	0861-0203000000	Screw Conn HxDc Ni 7mmx 50mm	
11	4	0861-0205000000	Screw Conn HxFl ZN 7mmx 50mm	



TM8350R – TM8352R

STEP-BY-STEP ASSEMBLY

ILLUSTRATIONS AND PART NUMBERS ARE FOR TM8352R.
 BASIC ASSEMBLY INSTRUCTIONS ARE THE SAME FOR BOTH MODELS.
 2-PERSON ASSEMBLY RECOMMENDED.

IMPORTANT!

*Be sure to keep all parts supported during assembly to avoid damage.
 Do not over-tighten screws or it will damage the pre-drilled holes;
 snug fit is adequate.*

HARDWARE / TOOLS INCLUDED

(Phillips screwdriver and soft mallet required but not included.)

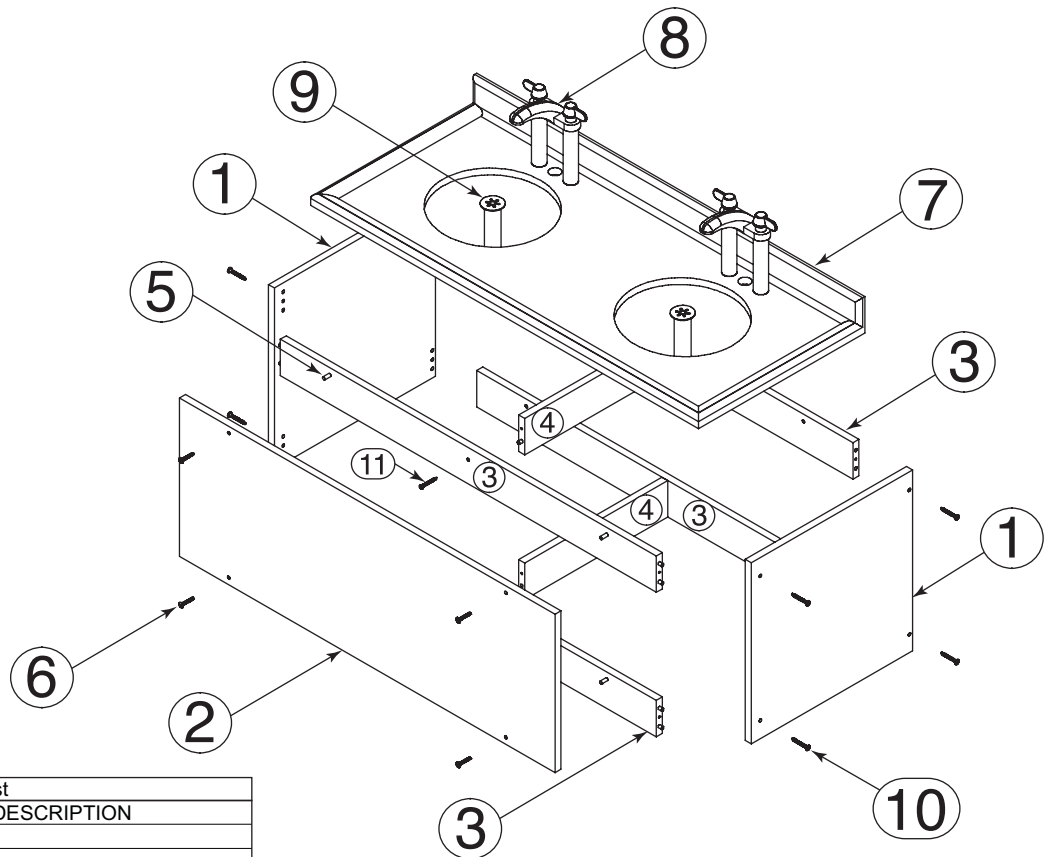
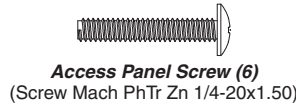
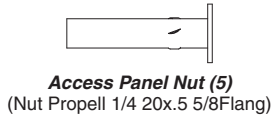
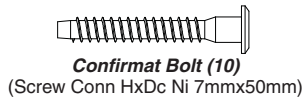

TM8352R Parts List

ITEM	QTY	PART #	DESCRIPTION
1	2	41XX-1501	End U
2	1	82XX-0253	Access Panel
3	4	61XX-0641	Rail-TK-Supt
4	2	61XX-0649	Rail-Xsupt
5	4	0861-0338000000	Nut Propell 1/4 20x.5 5/8Flang
6	4	0861-0032000000	Screw Mach PhTr Zn 1/4-20x1.50
7	1	0660-2709000000	Sink Dbl DDE4922SPW 21x49 Wht
8	2	0661-1259000000	Fauc PEER P241LF Lav 4"
9	2	0661-0008000000	Plbg Strainer Flat D70-100
10	8	0861-0203000000	Screw Conn HxDc Ni 7mmx 50mm
11	4	0861-0205000000	Screw Conn HxFI ZN 7mmx 50mm



STEP-BY-STEP ASSEMBLY

FOR TM8352R ONLY (STEP 1):

STEP 1

Construct two **Rail Supports** as follows:

- a. Insert dowels on ends of one **X Rail (4)** into holes in center of two **TK Rails (3)**. Make sure holes in ends of **X Rail (4)** align with thru-holes in **TK Rails (3)**. Press firmly into place.

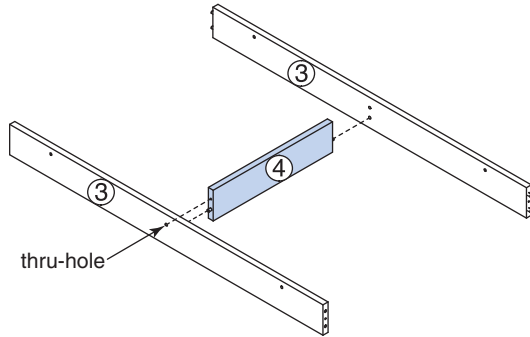

- b. Secure **Rails (3 & 4)** from (a.) together with two **Flat Head Conformat Bolts (11)**, using the included **Hex Wrench**.

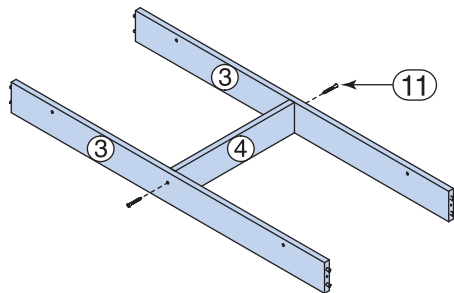

- c. Repeat (a.) and (b.) to construct other **Rail Support**.

FOR BOTH MODELS (STEPS 2-13):

STEP 2

Lay one **End (1)** flat on floor, with side having the most holes facing up. NOTE: Holes are closer to back edge and further from front edge.

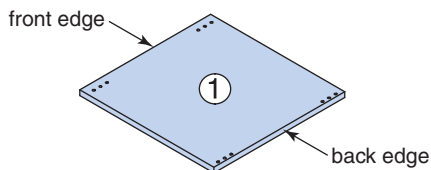

STEP 3

Insert dowels on **TK Rails (3)** into holes on **End (1)**. (For TM8352R, **TK Rails (3)** are part of the **Rail Supports** from **Step 1**.) Top edges of all **TK Rails (3)** must be facing same direction. Press firmly into place.

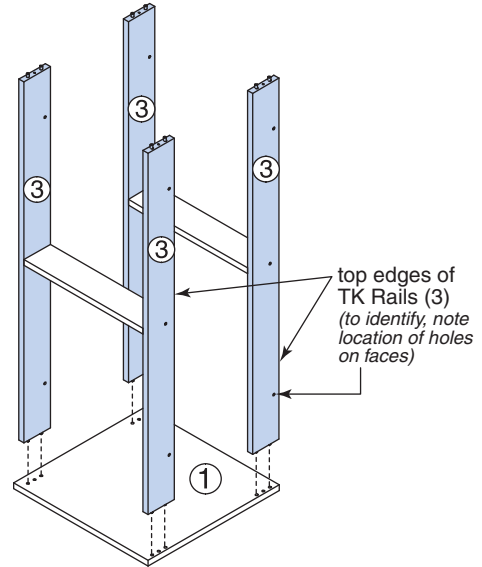

STEP 4

Position other **End (1)** on top of assembly, so dowels on **TK Rails (3)** align with holes on **End (1)** and back edges of both **Ends (1)** are facing same direction. Press firmly into place.

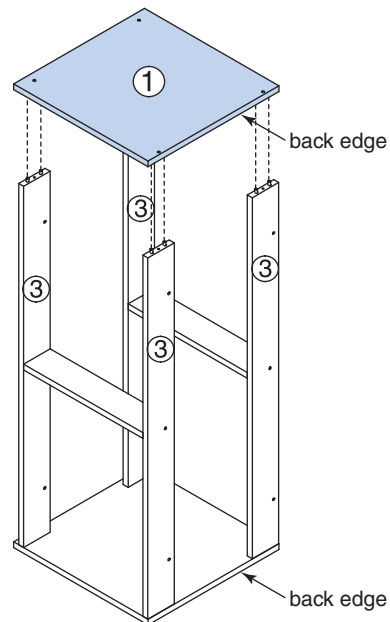



STEP-BY-STEP ASSEMBLY

STEP 5

Secure **End (1)** to **TK Rails (3)** with four **Confirmat Bolts (10)**.

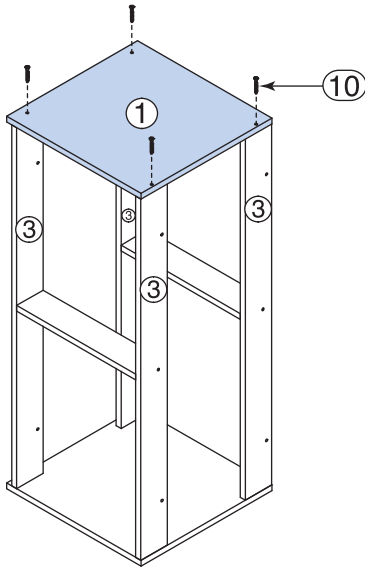

STEP 6

Carefully turn assembly over, so other **End (1)** is facing up.

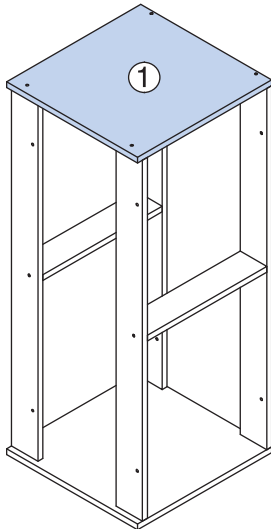

STEP 7

Repeat **Step 5** to secure **End (1)** to **TK Rails (3)**.

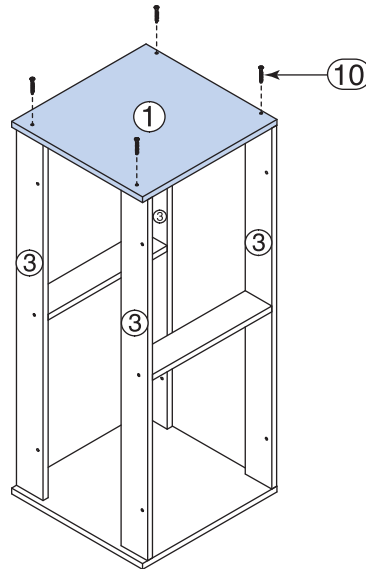

STEP 8

Carefully position assembly with front facing up.

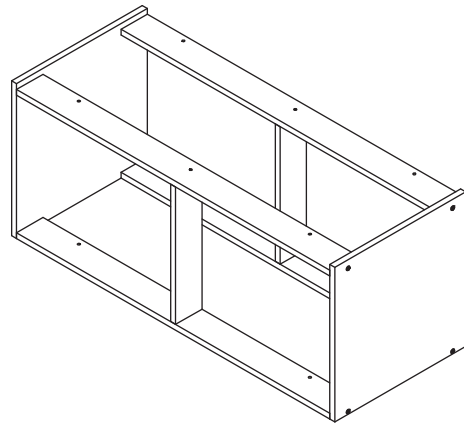

STEP 9

Insert **Access Panel Nuts (5)** into both holes on each front **TK Rail (3)**, with flange exposed to interior of cabinet. Tap **Access Panel Nuts (5)** into place with soft mallet.

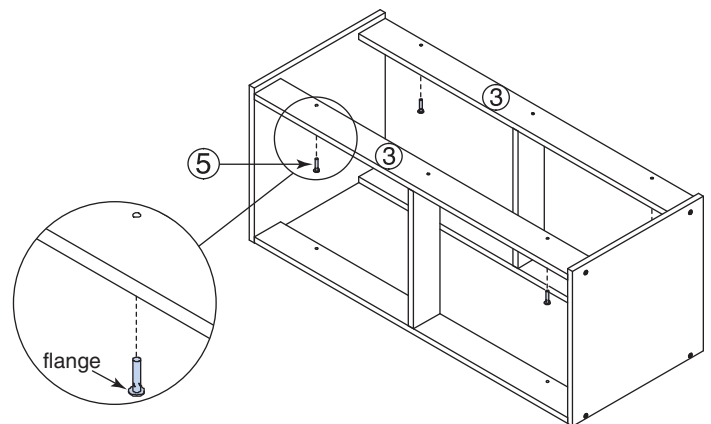



STEP-BY-STEP ASSEMBLY

STEP 10

Position **Access Panel (2)** over assembly, so holes on **Access Panel (2)** align with **Access Panel Nuts (5)**. Press firmly into place.

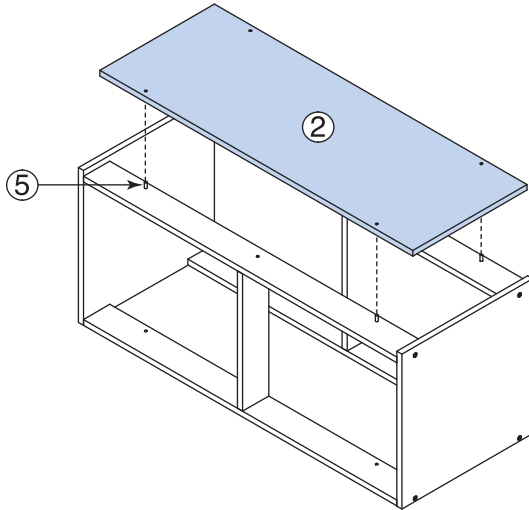

STEP 11

Secure **Access Panel (2)** to front **TK Rails (3)** with four **Access Panel Screws (6)**. (Phillips screwdriver not included.) **NOTE: The Access Panel can be removed as needed for plumbing access.**

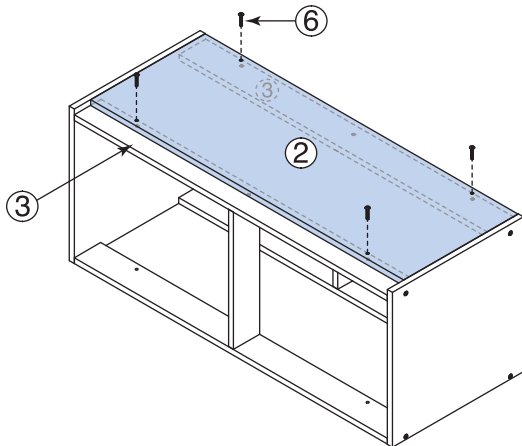

STEP 12

Carefully stand unit upright.

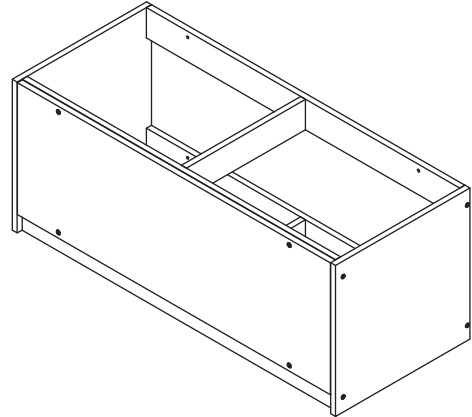

STEP 13

Ensure that all joints, bolts and screws are tight.

This completes the assembly of the cabinet.

Installation of Sinks (7), Faucets (8) and Strainers (9) to be performed by licensed plumber.