



by Stevens Industries, Inc.
 704 West Main St.
 Teutopolis, IL 62467
 P: 800.350.3270
 P: 217-857-7100 • F: 217-857-7101
 www.totmate.com

TM2336R
TM4336R

ATTENTION

Please unpack and assemble in an area away from children's activities. Remove all tools and excess materials from work area after assembly of unit is complete. Dispose of pallet and packaging materials in an environmentally friendly manner. If any parts are missing or damaged, please call Stevens for immediate parts replacement (1-800-350-3270). When ordering parts, give the Model Number and Color of the unit.



CAUTION – CHOKING HAZARD

Adult assembly required due to presence of small parts and sharp edges.

IMPORTANT!

Assembly must be securely attached to building structure with anchoring devices of appropriate type, size and quantity in accordance with applicable codes and accepted installation practices.

NOTE: ASSEMBLY INSTRUCTIONS REFERENCE ILLUSTRATIONS AND PART NUMBERS FOR THE TM2336R.



TM2336R
Diaper Wall Storage

			Parts List	
ITEM	QTY	PART #	DESCRIPTION	
1	2	41XX-1476	End U	
2	1	51XX-1273	Bottom	
3	1	51XX-1279	Shelf	
4	5	41XX-1477	Subdivider	
5	2	61XX-0630	Stringer	
6	1	51XX-1270	Top	
7	3	41XX-1472	Divider	
8	1	71XX-0641	Back	
9	10	0263-1696000000	Clip Shelf/Divider 1/4"x224mm	
10	19	0861-0203000000	Screw Conn HxDc Ni 7mmx 50mm	
11	1	0861-0205000000	Screw Conn HxFI ZN 7mmx 50mm	
12	2	0861-0445000000	Screw Tapp PhWh Zinc #8 X 1.25	



TM4336R
Diaper Wall Storage

			Parts List	
ITEM	QTY	PART #	DESCRIPTION	
1	1	5108-1280	Top	
2	2	4108-1481	End U	
3	1	5108-1281	Bottom	
4	1	71XX-0647	Back	
5	1	5108-1282	Shelf	
6	3	4108-1482	Divider	
7	5	51XX-1274	Subdivider	
8	2	6108-0632	Stringer	
9	10	0263-1696000000	Clip Shelf/Divider 1/4"x224mm	
10	19	0861-0203000000	Screw Conn HxDc Ni 7mmx 50mm	
11	1	0861-0205000000	Screw Conn HxFI ZN 7mmx 50mm	
12	2	0861-0445000000	Screw Tapp PhWh Zinc #8 X 1.25	



TM2336R – TM4336R

STEP-BY-STEP ASSEMBLY

**ILLUSTRATIONS AND PART NUMBERS ARE FOR TM2336R.
ASSEMBLY INSTRUCTIONS ARE THE SAME FOR BOTH MODELS.
2-PERSON ASSEMBLY RECOMMENDED.**

IMPORTANT!

**Be sure to keep all parts supported during assembly to avoid damage.
Do not over-tighten screws or it will damage the pre-drilled holes;
snug fit is adequate.**

HARDWARE / TOOLS INCLUDED

(Phillips screwdriver required but not included.)

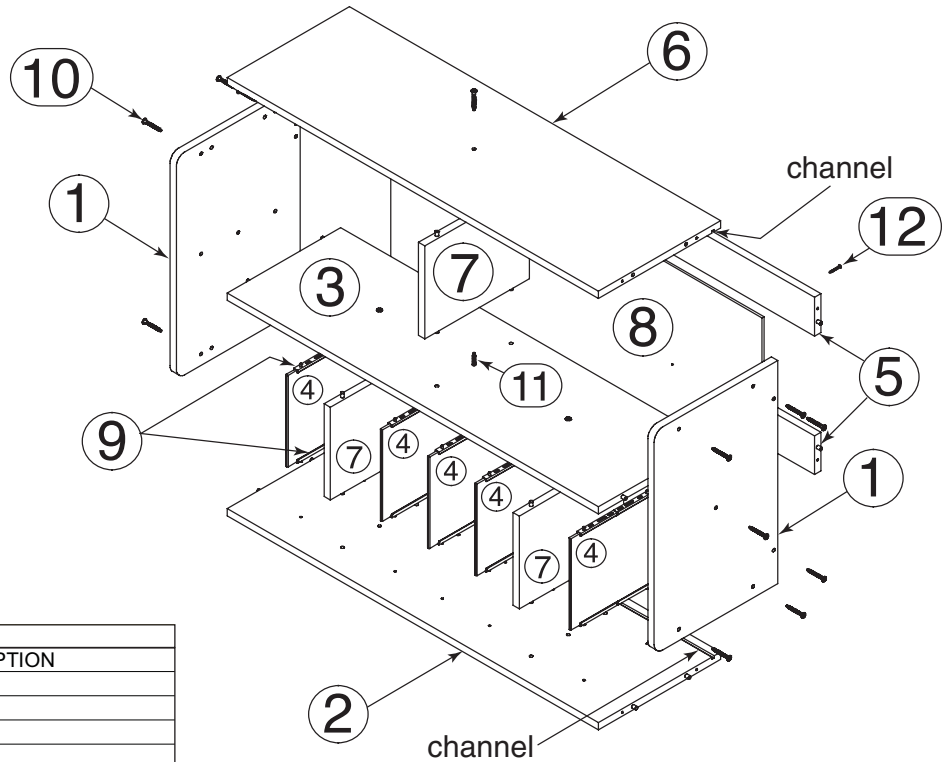
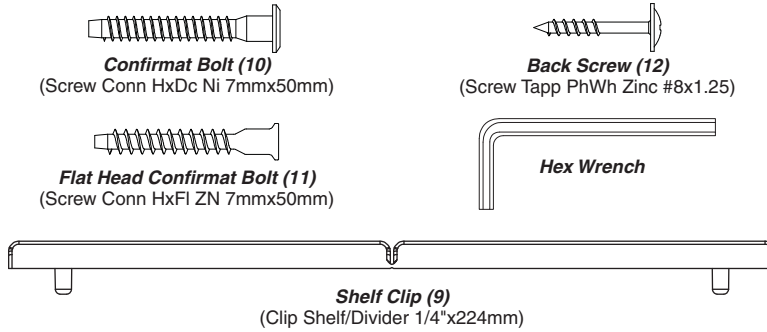

TM2336R Parts List			
ITEM	QTY	PART #	DESCRIPTION
1	2	41XX-1476	End U
2	1	51XX-1273	Bottom
3	1	51XX-1279	Shelf
4	5	41XX-1477	Subdivider
5	2	61XX-0630	Stringer
6	1	51XX-1270	Top
7	3	41XX-1472	Divider
8	1	71XX-0641	Back
9	10	0263-1696000000	Clip Shelf/Divider 1/4"x224mm
10	19	0861-0203000000	Screw Conn HxDc Ni 7mmx 50mm
11	1	0861-0205000000	Screw Conn HxFl ZN 7mmx 50mm
12	2	0861-0445000000	Screw Tapp PhWh Zinc #8 X 1.25



STEP-BY-STEP ASSEMBLY

STEP 1

Identify **Top (6)** and **Bottom (2)**. Note that routed channels on **Top (6)** and **Bottom (2)** will face interior of unit and hold **Back (8)** in place. To differentiate the parts, note that **Bottom (2)** has more holes than **Top (6)**.

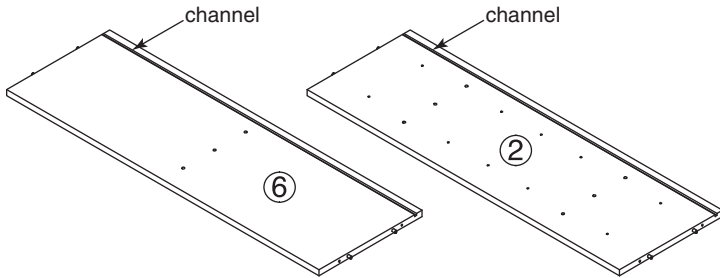

STEP 2

Lay **Bottom (2)** on floor, with side having the most holes facing up. Channel will be facing up. Insert dowels on two **Dividers (7)** into holes on **Bottom (2)**, making sure raw edges of **Dividers (7)** are facing toward channel on **Bottom (2)**. Press firmly into place.

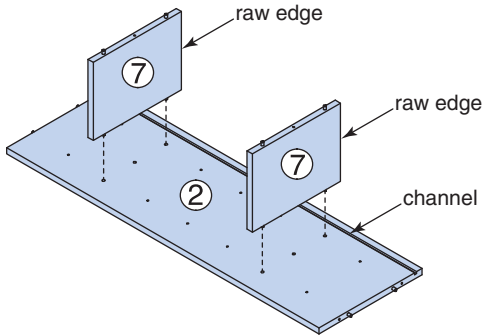

STEP 3

With side of **Shelf (3)** having the most holes facing down, align holes on **Shelf (3)** with dowels on standing **Dividers (7)**. Make sure all raw edges are facing same direction. Press firmly into place.

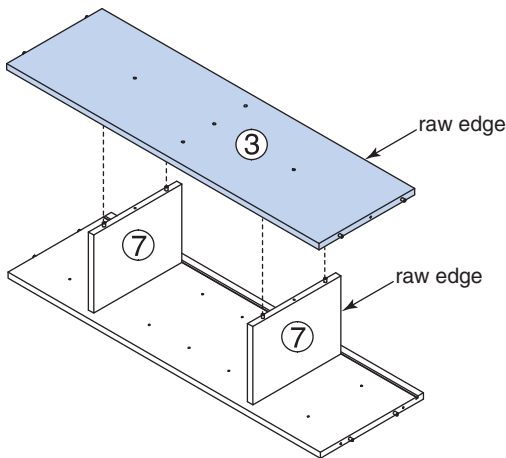

STEP 4

Secure **Shelf (3)** and **Bottom (2)** to **Dividers (7)** with four **Confirmat Bolts (10)**, using the included **Hex Wrench**.

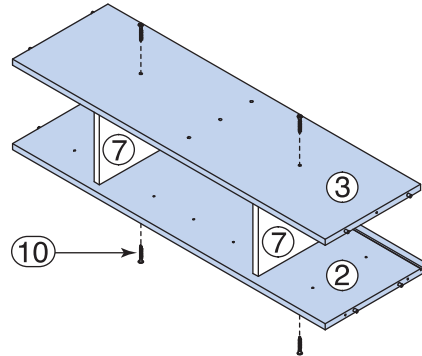

STEP 5

Insert dowels on remaining **Divider (7)** into holes on **Shelf (3)**. Make sure raw edges are facing same direction. Press firmly into place.

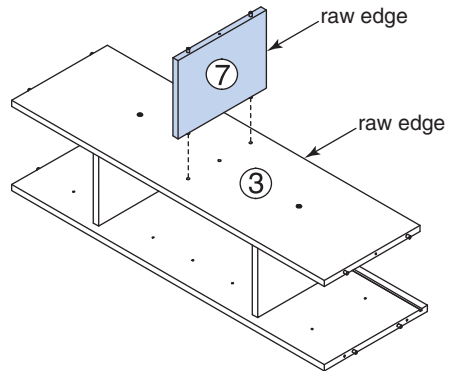

STEP 6

With side of **Top (6)** having the most holes facing down, align holes on **Top (6)** with dowels on **Divider (7)**. Make sure channel on **Top (6)** is aligned with channel on **Bottom (2)**. Press firmly into place.

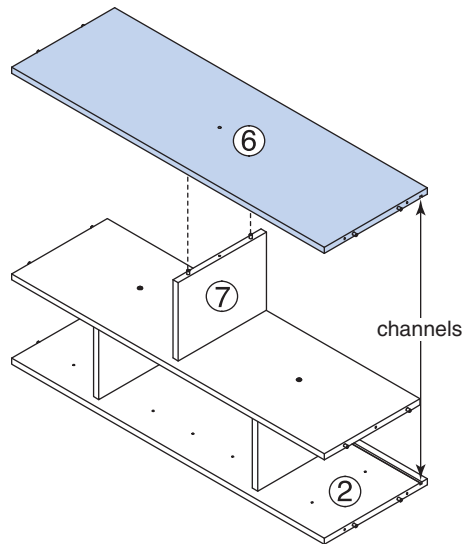



STEP-BY-STEP ASSEMBLY

STEP 7 Secure **Shelf (3)** to **Divider (7)** with **Flat Head Confirmat Bolt (11)**. Secure **Top (6)** to **Divider (7)** with **Confirmat Bolt (10)**. This will be referred to as the **Shelf/Divider Assembly** in **Step 9**.

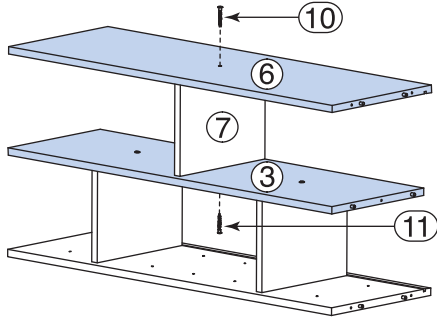

STEP 8 Lay one **End (1)** on floor with side having the most holes facing up.

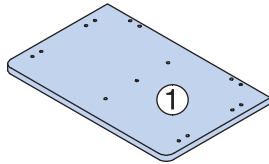

STEP 9 Insert dowels on one end of **Shelf/Divider Assembly** from **Step 7** into holes on **End (1)**. Make sure raw edges and channels on **Shelf/Divider Assembly** are facing toward back (flat) edge of **End (1)**. Press firmly into place.

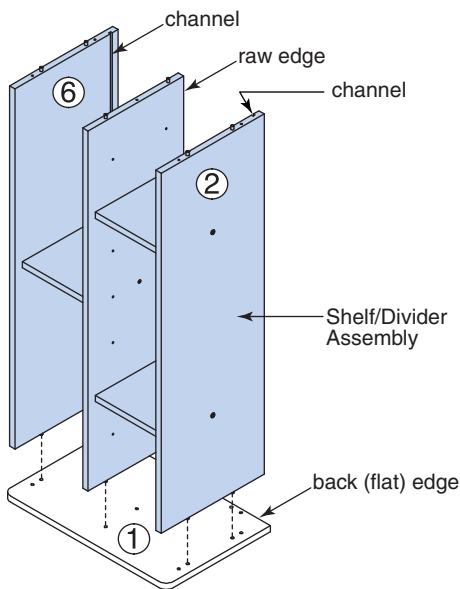

STEP 10 Slide **Back (8)** into channels on **Top (6)** and **Bottom (2)**. Seat firmly against **End (1)**. When seated, make sure holes on **Back (8)** align with back edge of **Shelf (3)**.

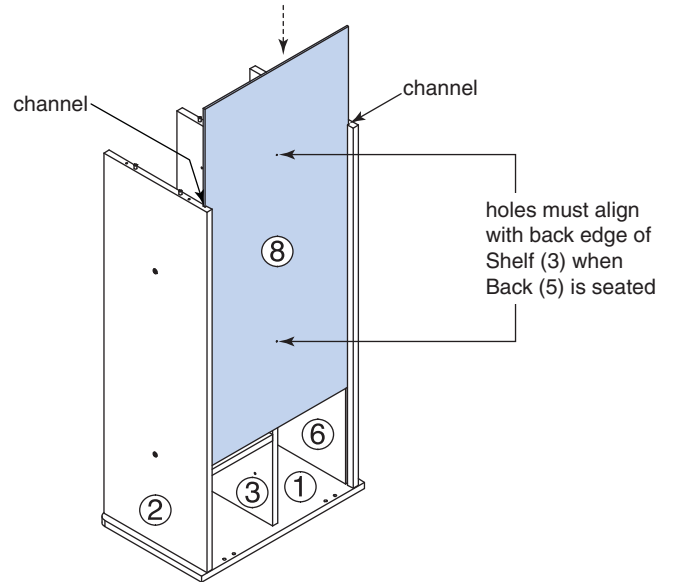

STEP 11 Insert dowels on **Stringers (5)** into remaining holes on **End (1)**. Make sure holes on **Stringers (5)** align with thru-holes on **End (1)**. Press firmly into place.

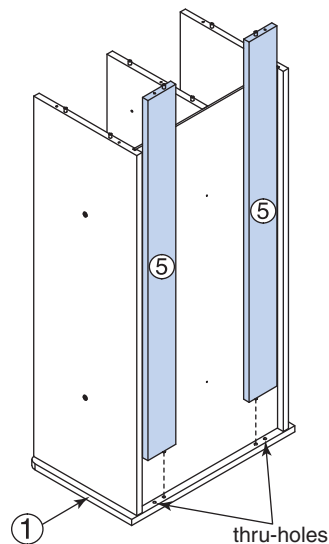



STEP-BY-STEP ASSEMBLY

STEP 12

Position other **End (1)** on top of assembly, so dowels on **Top (6)**, **Bottom (2)** and **Stringers (5)** align with holes on **End (1)**. Press firmly into place.

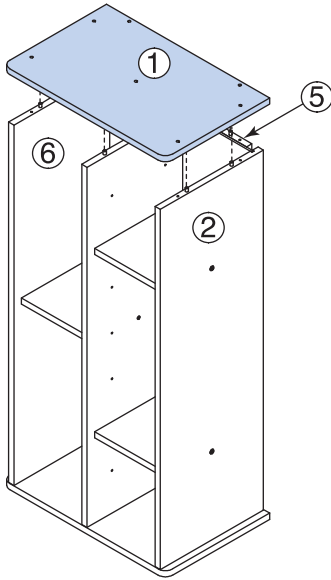

STEP 14

Carefully turn unit over, so other **End (1)** is facing up. Repeat **Step 13** to secure other **End (1)** to **Top (6)**, **Bottom (2)** and **Stringers (5)**.

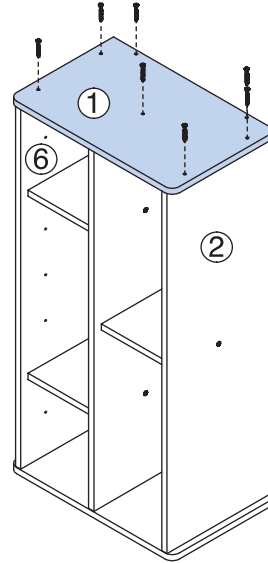

STEP 13

Secure **End (1)** to **Top (6)**, **Bottom (2)** and **Stringers (5)** with seven **Confirmat Bolts (10)**.

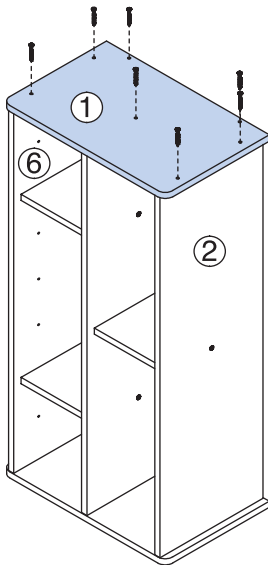

STEP 15

Carefully position unit with front edge on floor and back facing up.

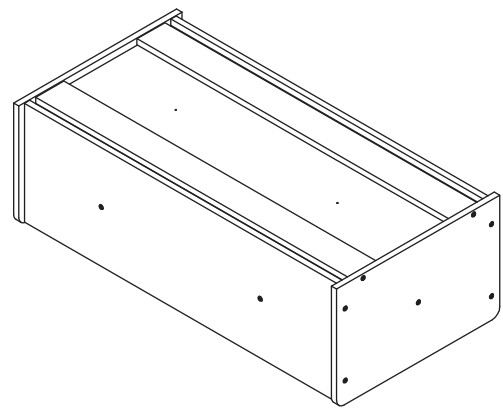



STEP-BY-STEP ASSEMBLY

STEP 16

Secure **Back (8)** to **Shelf (3)** with two **Back Screws (12)**. (Phillips screwdriver not included.) **IMPORTANT! Make sure Back Screws are centered on raw edge of Shelf and inserted straight into Shelf. This is necessary to prevent Back Screws from protruding through and damaging Shelf surface.**

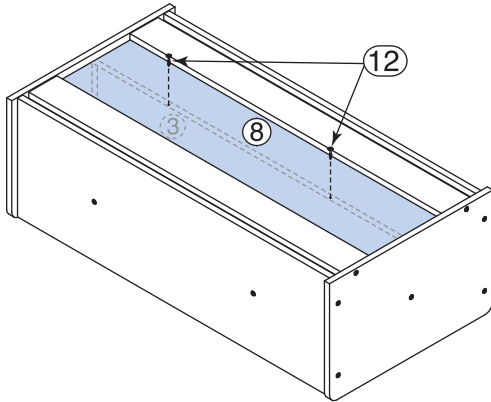

STEP 17

Carefully lay unit onto its back.

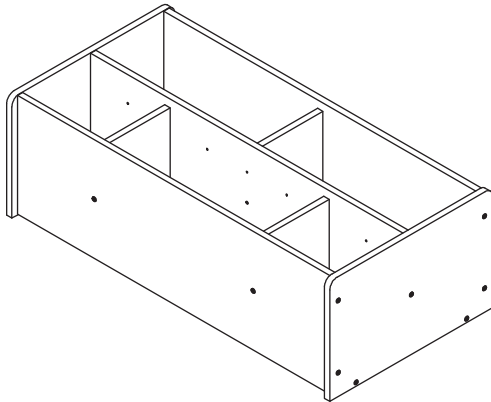

STEP 19

Slide **Subdividers (4)** into **Shelf Clips (9)**, ensuring rounded edges are facing front of unit.

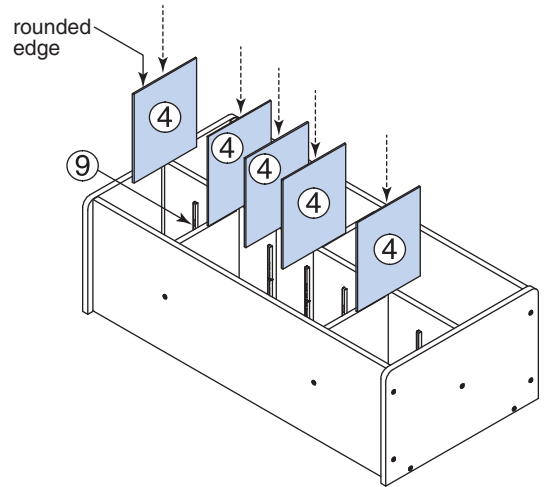

STEP 20

Carefully stand unit upright.

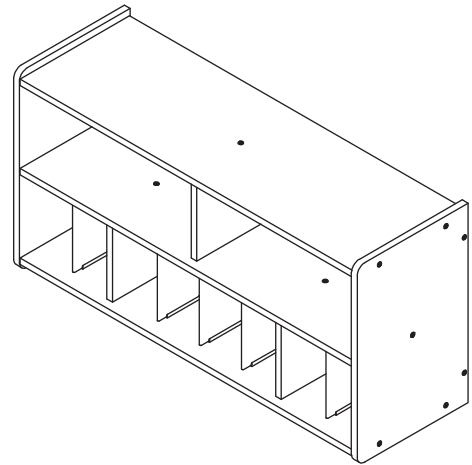

STEP 21

Ensure that all joints, bolts and screws are tight.

This completes the assembly.