



by Stevens Industries, Inc.
 704 West Main St.
 Teutopolis, IL 62467
 P: 800.350.3270
 P: 217-857-7100 • F: 217-857-7101
 www.totmate.com

TM2321R TM2325R

ATTENTION

Please unpack and assemble in an area away from children's activities. Remove all tools and excess materials from work area after assembly of unit is complete. Dispose of pallet and packaging materials in an environmentally friendly manner. If any parts are missing or damaged, please call Stevens for immediate parts replacement (1-800-350-3270).
 When ordering parts, give the Model Number and Color of the unit.



CAUTION – CHOKING HAZARD

Adult assembly required due to presence of small parts and sharp edges.

NOTE: ASSEMBLY INSTRUCTIONS REFERENCE ILLUSTRATIONS AND PART NUMBERS FOR THE TM2325R.



**TM2321R
 Mobile Desk**

			Parts List	
ITEM	QTY	PART #	DESCRIPTION	
1	1	61XX-0654	Support	
2	1	41XX-1519	End R	
3	1	51XX-1316	Top	
4	1	41XX-1518	End L	
5	1	82XX-0192	Front	
6	1	51XX-1317	Shelf	
7	14	0861-0203000000	Screw Conn HxDc Ni 7mmx 50mm	
8	4	0463-0705000000	Cstr U 50mm Twin W/B 3/4in Set	



**TM2325R
 Mobile Desk**

			Parts List	
ITEM	QTY	PART #	DESCRIPTION	
1	1	41XX-1518	End L	
2	1	41XX-1519	End R	
3	1	61XX-0655	Support	
4	1	51XX-1318	Top	
5	1	82XX-0193	Front	
6	1	51XX-1319	Shelf	
7	18	0861-0203000000	Screw Conn HxDc Ni 7mmx 50mm	
8	4	0463-0705000000	Cstr U 50mm Twin W/B 3/4in Set	



TM2321R – TM2325R

STEP-BY-STEP ASSEMBLY

ILLUSTRATIONS AND PART NUMBERS ARE FOR TM2325R.
 BASIC ASSEMBLY INSTRUCTIONS ARE THE SAME FOR BOTH MODELS.
 2-PERSON ASSEMBLY RECOMMENDED.

IMPORTANT!

*Be sure to keep all parts supported during assembly to avoid damage.
 Do not over-tighten screws or it will damage the pre-drilled holes;
 snug fit is adequate.*

HARDWARE / TOOLS INCLUDED

(Phillips screwdriver required but not included.)

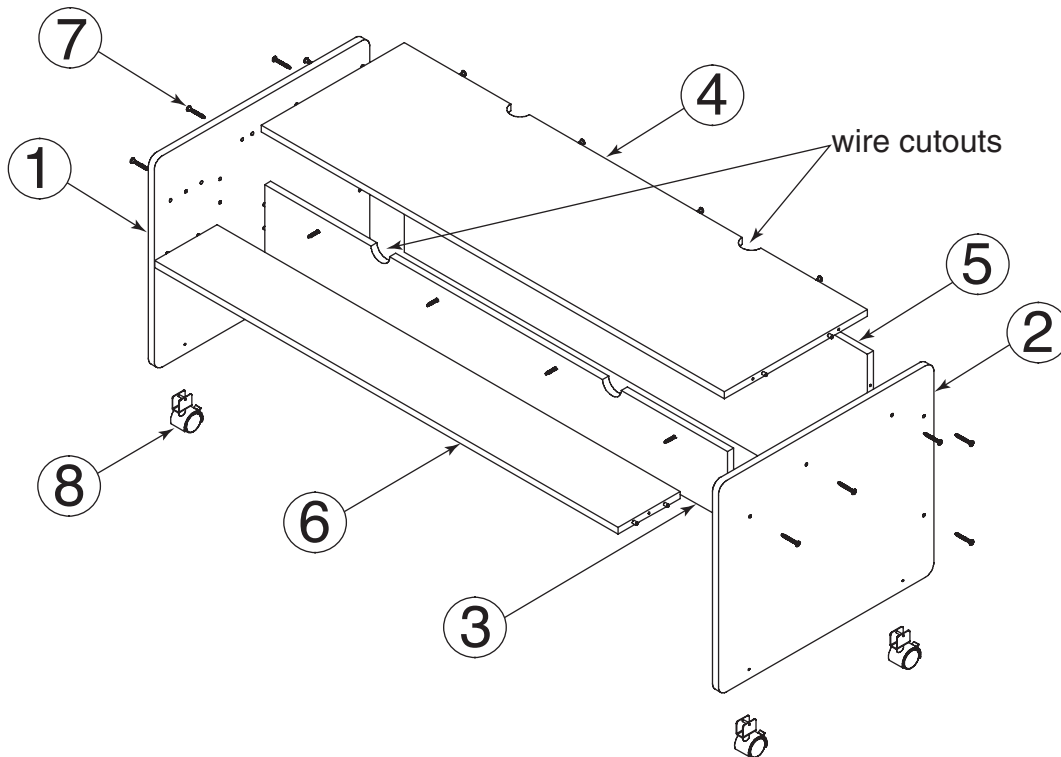
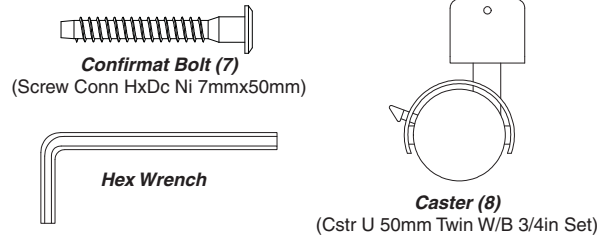

TM2325R Parts List			
ITEM	QTY	PART #	DESCRIPTION
1	1	41XX-1518	End L
2	1	41XX-1519	End R
3	1	61XX-0655	Support
4	1	51XX-1318	Top
5	1	82XX-0193	Front
6	1	51XX-1319	Shelf
7	18	0861-0203000000	Screw Conn HxDc Ni 7mmx 50mm
8	4	0463-0705000000	Cstr U 50mm Twin W/B 3/4in Set



STEP-BY-STEP ASSEMBLY

STEP 1

Lay **Left End (1)** flat on floor, with side having the most holes facing up.

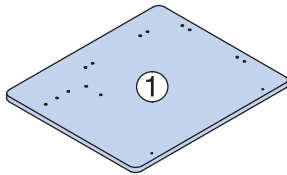

STEP 2

Insert dowels on **Front (5)**, **Top (4)**, **Support (3)** and **Shelf (6)** into holes on **Left End (1)**. Make sure raw edges are not exposed, and wire cutouts are oriented correctly, as shown. Make sure four holes on face of **Front (5)** align with holes on edge of **Top (4)**, and four holes on face of **Support (3)** align with holes on edge of **Shelf (6)** (reference **DETAILS A & B**). Press all parts firmly into place.

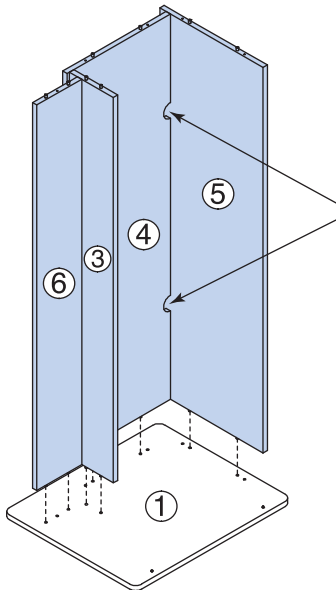

wire cutouts

NOTE: Wire cutouts on Support (3) are not visible – reference exploded view on page 2.

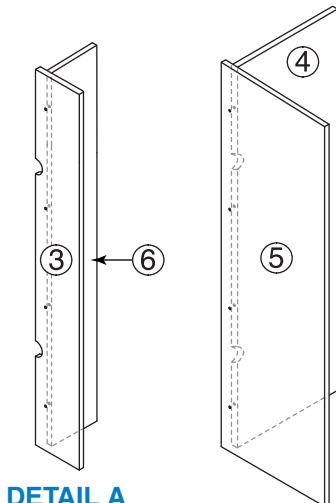

DETAIL A

DETAIL B

STEP 3

Position **Right End (2)** on top of assembly, so dowels on **Front (5)**, **Top (4)**, **Support (3)** and **Shelf (6)** align with holes on **Right End (2)**. Press firmly into place.

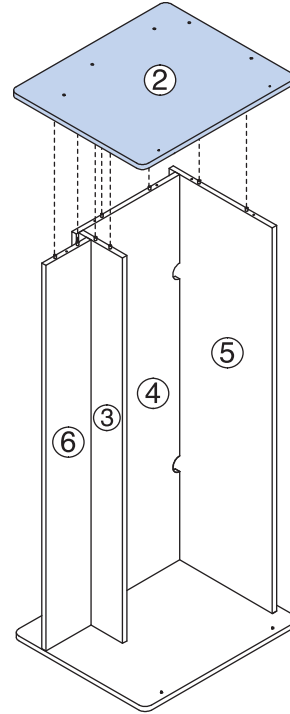

STEP 4

Secure **Right End (2)** to **Front (5)**, **Top (4)**, **Support (3)** and **Shelf (6)** with five **Confirmat Bolts (7)**, using the included **Hex Wrench**.

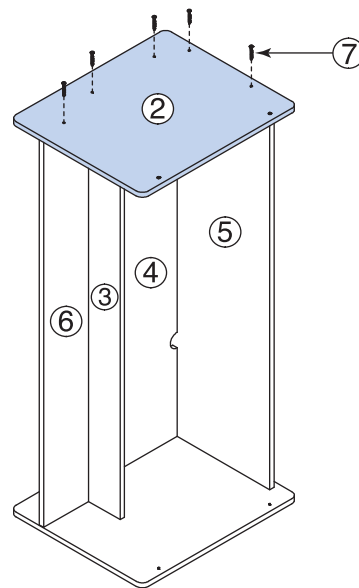



TM2321R – TM2325R

STEP-BY-STEP ASSEMBLY

STEP 5 Carefully turn assembly over, so **Left End (1)** is facing up.

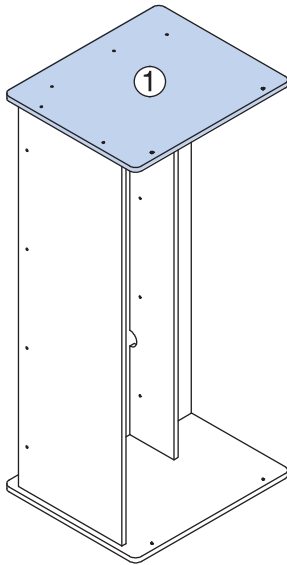

STEP 7 Secure **Front (5)** to **Top (4)** with four **Confirmat Bolts (7)** through the aligned holes.

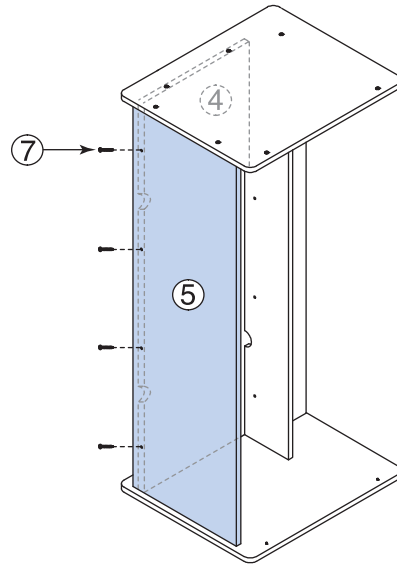

STEP 6 Repeat **Step 4** to secure **Left End (1)** to **Front (5)**, **Top (4)**, **Support (3)** and **Shelf (6)**.

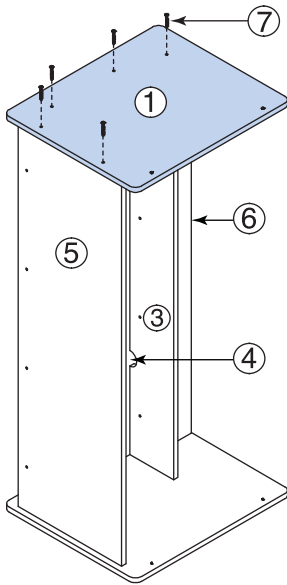

STEP 8 Secure **Support (3)** to **Shelf (6)** with four **Confirmat Bolts (7)** through the aligned holes.

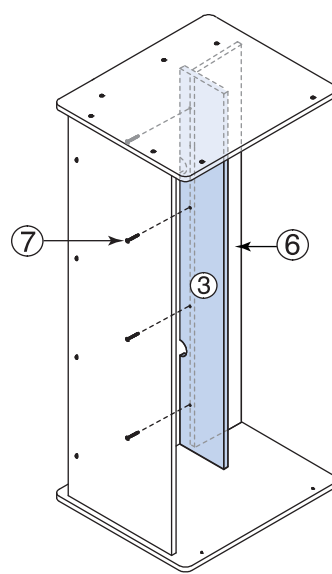



STEP-BY-STEP ASSEMBLY

STEP 9

Carefully position the assembly with the bottom edge facing up.

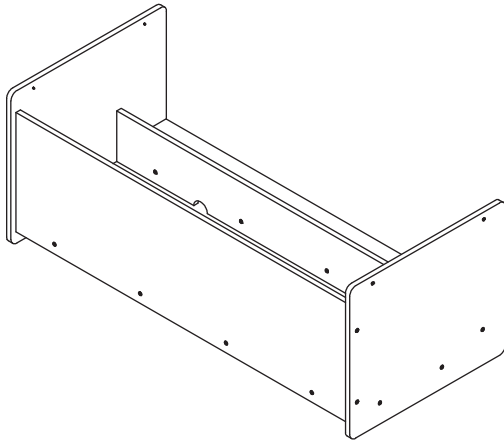

STEP 10

Align mounting bracket holes on **Casters (8)** with holes along bottom edge of **Ends (1 & 2)**.

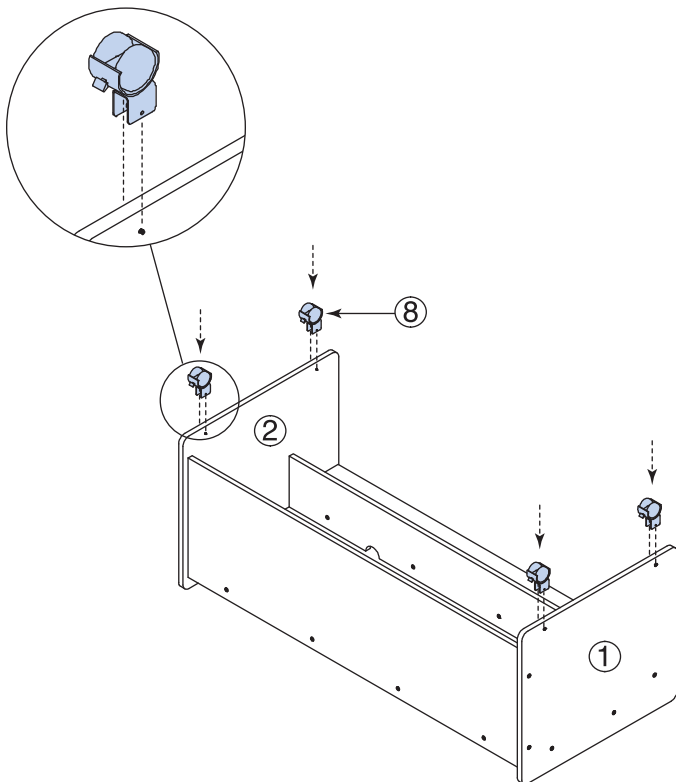

STEP 11

Mount **Casters (8)** to **Ends (1 & 2)** by securing screws through aligned holes on mounting brackets and **Ends (1 & 2)** from outside to inside. (Phillips screwdriver not included.)

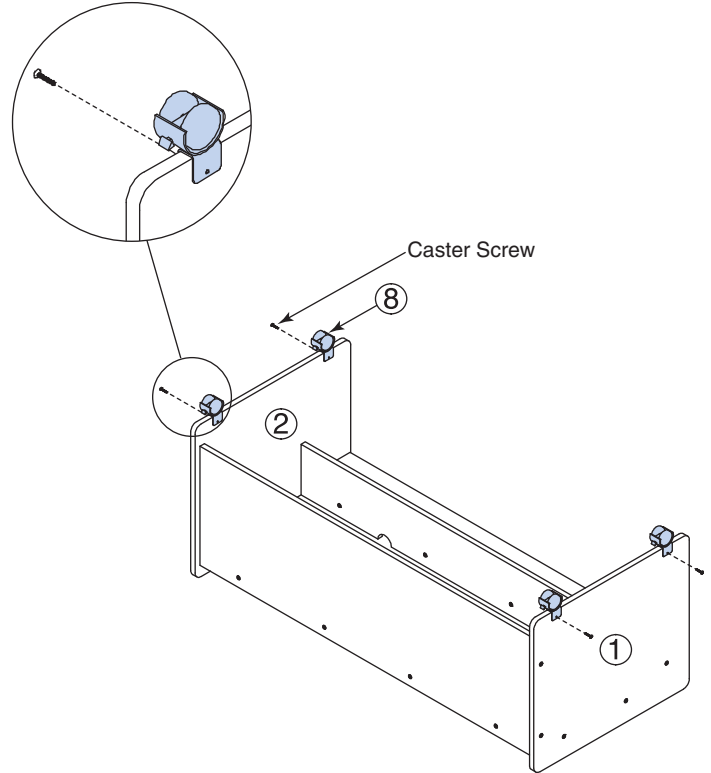

STEP 12

Carefully stand unit upright onto casters.

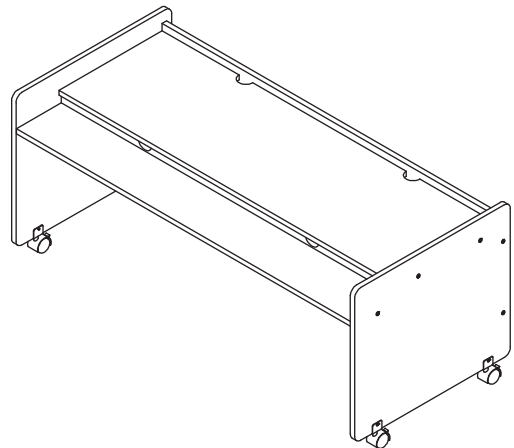

STEP 13

Ensure that all joints, bolts and screws are tight.

This completes the assembly.