



by Stevens Industries, Inc.
 704 West Main St.
 Teutopolis, IL 62467
 P: 800.350.3270
 P: 217-857-7100 • F: 217-857-7101
 www.totmate.com

TMS302R
TM2302R
TMS301R
TM2304R

ATTENTION

Please unpack and assemble in an area away from children's activities. Remove all tools and excess materials from work area after assembly of unit is complete. Dispose of pallet and packaging materials in an environmentally friendly manner. If any parts are missing or damaged, please call Stevens for immediate parts replacement (1-800-350-3270). When ordering parts, give the Model Number and Color of the unit.



CAUTION – CHOKING HAZARD

Adult assembly required due to presence of small parts and sharp edges.

NOTE: ASSEMBLY INSTRUCTIONS REFERENCE ILLUSTRATIONS AND PART NUMBERS FOR THE TM2302R.



TMS302R
 Toddler Shelf Storage

			Parts List	
ITEM	QTY	PART #	DESCRIPTION	
1	2	51XX-1306	Top-Bot	
2	1	71XX-0670	Back	
3	1	51XX-1307	Shelf	
4	2	41XX-1471	End U	
5	10	0861-0203000000	Screw Conn HxDc Ni 7mmx 50mm	

NOTE: Hardware bag includes (2) 0861-0445000000 Screw Tapp PhWh Zinc #8x1.25, but they are NOT to be used with the TMS302R.



TM2302R
 Toddler Shelf Storage

			Parts List	
ITEM	QTY	PART #	DESCRIPTION	
1	1	51XX-1272	Shelf	
2	2	51XX-1271	Top	
3	2	41XX-1471	End U	
4	1	71XX-0641	Back	
5	2	0861-0445000000	Screw Tapp PhWh Zinc #8 X 1.25	
6	10	0861-0203000000	Screw Conn HxDc Ni 7mmx 50mm	



TMS301R
 Preschool Shelf Storage

			Parts List	
ITEM	QTY	PART #	DESCRIPTION	
1	1	71XX-0668	Back	
2	2	51XX-1306	Top-Bot	
3	1	51XX-1307	Shelf	
4	2	41XX-1475	End U	
5	10	0861-0203000000	Screw Conn HxDc Ni 7mmx 50mm	

NOTE: Hardware bag includes (2) 0861-0445000000 Screw Tapp PhWh Zinc #8x1.25, but they are NOT to be used with the TMS301R.



TM2304R
 Preschool Shelf Storage

			Parts List	
ITEM	QTY	PART #	DESCRIPTION	
1	2	41XX-1475	End U	
2	1	71XX-0643	Back	
3	1	51XX-1272	Shelf	
4	2	51XX-1271	Top	
5	10	0861-0203000000	Screw Conn HxDc Ni 7mmx 50mm	
6	2	0861-0445000000	Screw Tapp PhWh Zinc #8 X 1.25	



TMS302R – TM2302R – TMS301R – TM2304R

STEP-BY-STEP ASSEMBLY

ILLUSTRATIONS AND PART NUMBERS ARE FOR TM2302R.
 BASIC ASSEMBLY INSTRUCTIONS ARE THE SAME FOR ALL 4 MODELS.
 2-PERSON ASSEMBLY RECOMMENDED.

IMPORTANT!

*Be sure to keep all parts supported during assembly to avoid damage.
 Do not over-tighten screws or it will damage the pre-drilled holes;
 snug fit is adequate.*

HARDWARE / TOOLS INCLUDED

(Phillips screwdriver required but not included.)



Confirmat Bolt (6)
 (Screw Conn HxDc Ni 7mmx50mm)

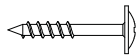

Back Screw (5)
 (Screw Tapp PhWh Zinc #8x1.25)



Hex Wrench

*Back Screws are included in the
 TMS301R and TMS302R hardware bags,
 but they are NOT to be used with the
 TMS301R and TMS302R.*

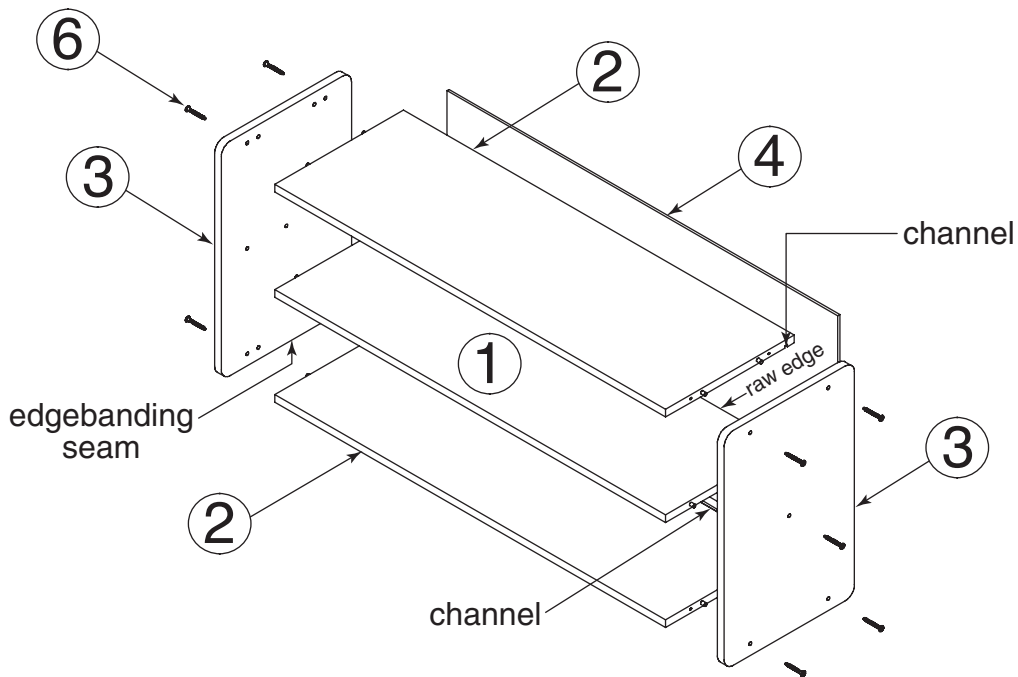

TM2302R Parts List			
ITEM	QTY	PART #	DESCRIPTION
1	1	51XX-1272	Shelf
2	2	51XX-1271	Top
3	2	41XX-1471	End U
4	1	71XX-0641	Back
5	2	0861-0445000000	Screw Tapp PhWh Zinc #8 X 1.25
6	10	0861-0203000000	Screw Conn HxDc Ni 7mmx 50mm



STEP-BY-STEP ASSEMBLY

STEP 1

Locate **Tops (2)** and **Ends (3)**. Note that routed channels along back edges of **Tops (2)** will face interior of unit for installation of **Back (4)**. Also, note location of edgbanding seam on **Ends (3)**. **IMPORTANT: Edgbanding seams must be on the bottom of the unit when assembly is complete.**

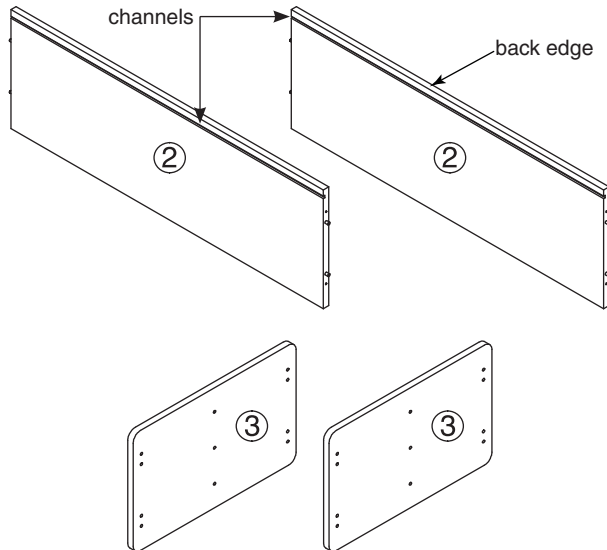

STEP 2

With **End (3)** resting on its front edge, insert dowels on one **Top (2)** into holes on **End (3)**. Make sure back edge of **Top (2)** is facing up and channel is facing toward interior of unit. Press firmly into place. Secure **Top (2)** to **End (3)** with two **Confirmat Bolts (6)**.

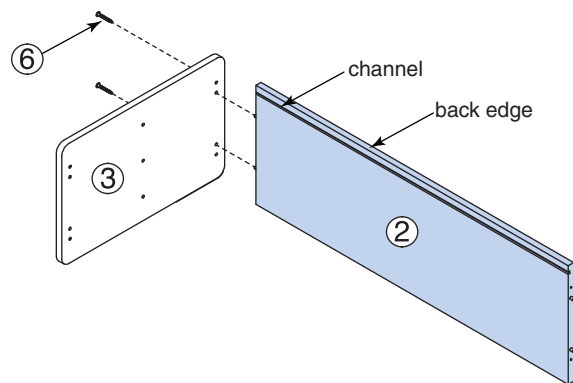

STEP 3

Repeat **Step 2** with other **Top (2)**. Make sure channel is facing toward interior of unit and channels on both **Tops (2)** are aligned.

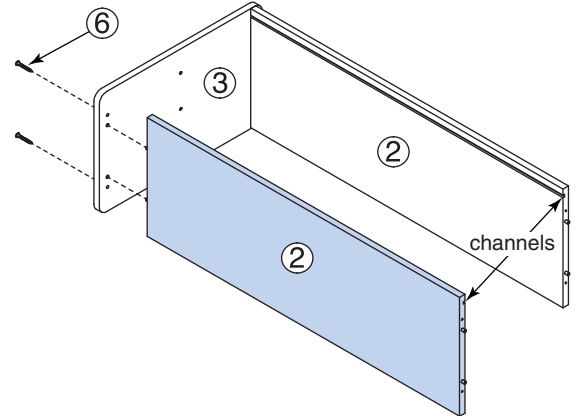

STEP 4

Insert dowels on **Shelf (1)** into remaining holes on **End (3)**. Make sure raw edge is facing up (toward back of unit). Press firmly into place. Secure **Shelf (1)** to **End (3)** with **Confirmat Bolt (6)**.

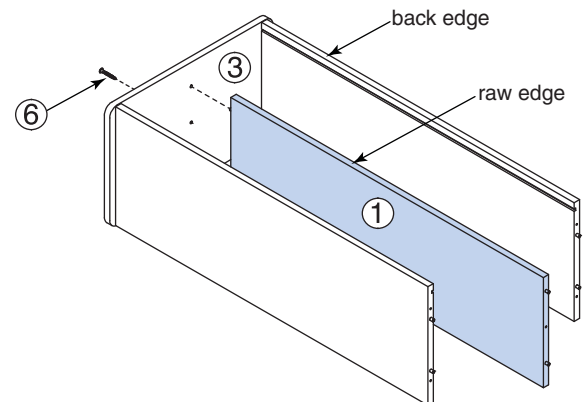

STEP 5

Slide **Back (4)** into channels on **Tops (2)**. Seat firmly against **End (3)**. (Note that Backs for TMS301R/TMS302R do not have any pre-drilled holes.)

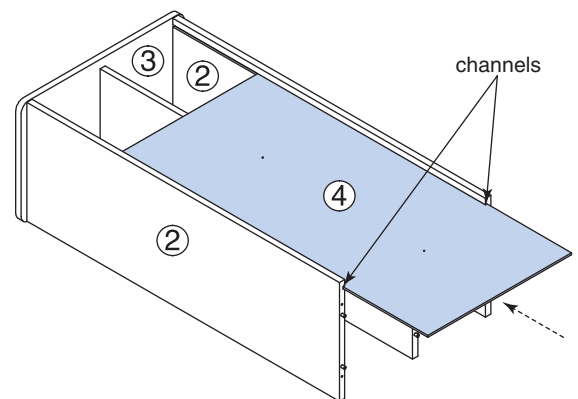



STEP-BY-STEP ASSEMBLY

STEP 6

Position other **End (3)** at opposite end of unit, so dowels on **Tops (2)** and **Shelf (1)** align with holes on **End (3)**. Make sure edgebanding seam is on bottom of unit. **Edgebanding seam on both Ends (3) must be facing same direction. HINT: Propping up Tops and Shelf will allow End to be positioned without obstruction.**

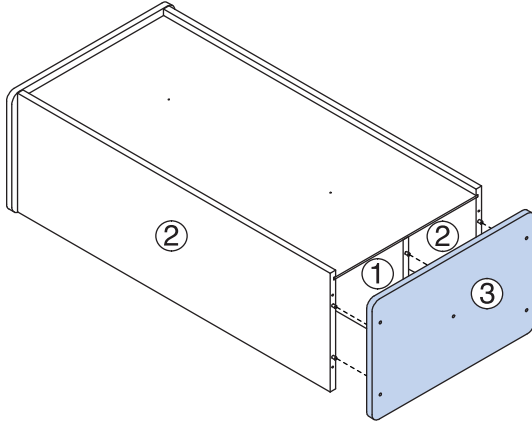

STEP 7

Secure **End (3)** to **Tops (2)** and **Shelf (1)** with five **Confirmat Bolts (6)**.

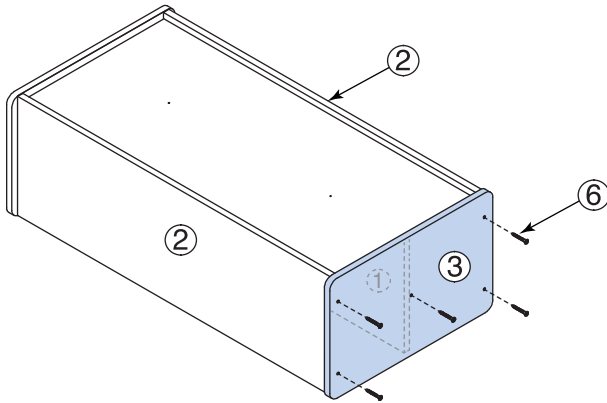

NOTE:
For TMS301R and TMS302R, skip Step 8.

STEP 8

Secure **Back (4)** to **Shelf (1)** with two **Back Screws (5)**. (Phillips screwdriver not included.) **IMPORTANT! Make sure Back Screws are centered on edge of Shelf and inserted straight into Shelf. This is necessary to prevent Back Screws from protruding through and damaging Shelf surface. (Note that TMS301R and TMS302R do not require Back Screws.)**

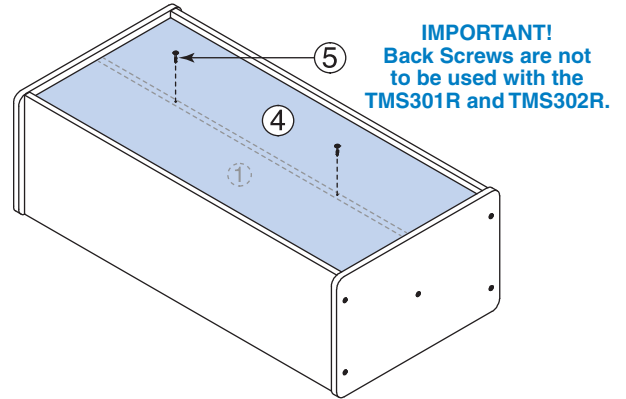

STEP 9

Carefully stand unit upright. Make sure edgebanding seams on **Ends (2)** are on bottom of unit.

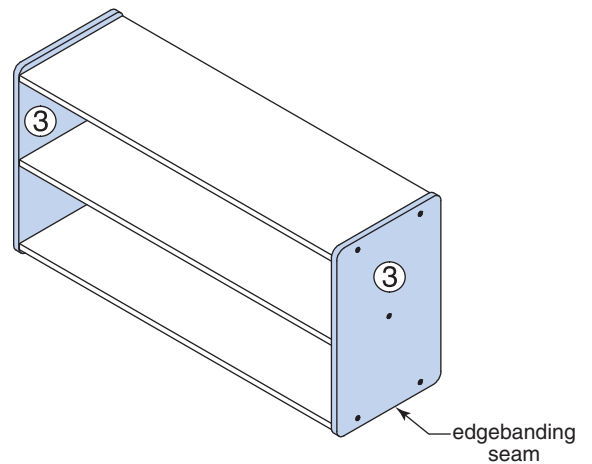

STEP 10

Ensure that all joints, bolts and screws are tight.

This completes the assembly.