



by Stevens Industries, Inc.  
 704 West Main St.  
 Teutopolis, IL 62467  
 P: 800.350.3270  
 P: 217-857-7100 • F: 217-857-7101  
 www.totmate.com

# TM2224R TM2226R

## ATTENTION

Please unpack and assemble in an area away from children's activities. Remove all tools and excess materials from work area after assembly of unit is complete. Dispose of pallet and packaging materials in an environmentally friendly manner. If any parts are missing or damaged, please call Stevens for immediate parts replacement (1-800-350-3270). When ordering parts, give the Model Number and Color of the unit.



### CAUTION – CHOKING HAZARD

Adult assembly required due to presence of small parts and sharp edges.

**NOTE: ASSEMBLY INSTRUCTIONS REFERENCE ILLUSTRATIONS AND PART NUMBERS FOR THE TM2224R.**



**TM2224R**  
**Toddler Shelf Storage – Double Sided**

Parts List			
ITEM	QTY	PART #	DESCRIPTION
1	3	51XX-1278	Top-Bot
2	2	41XX-1479	End U
3	2	71XX-0645	Back
4	18	0861-0203000000	Screw Conn HxDc Ni 7mmx 50mm



**TM2226R**  
**Preschool Shelf Storage – Double Sided**

Parts List			
ITEM	QTY	PART #	DESCRIPTION
1	2	71XX-0646	Back
2	3	51XX-1278	Top-Bot
3	2	41XX-1488	End U
4	18	0861-0203000000	Screw Conn HxDc Ni 7mmx 50mm



# TM2224R – TM2226R

## STEP-BY-STEP ASSEMBLY

ILLUSTRATIONS AND PART NUMBERS ARE FOR TM2224R.  
 BASIC ASSEMBLY INSTRUCTIONS ARE THE SAME FOR BOTH MODELS.  
 2-PERSON ASSEMBLY RECOMMENDED.

**IMPORTANT!**

*Be sure to keep all parts supported during assembly to avoid damage.  
 Do not over-tighten screws or it will damage the pre-drilled holes;  
 snug fit is adequate.*

### HARDWARE / TOOLS INCLUDED

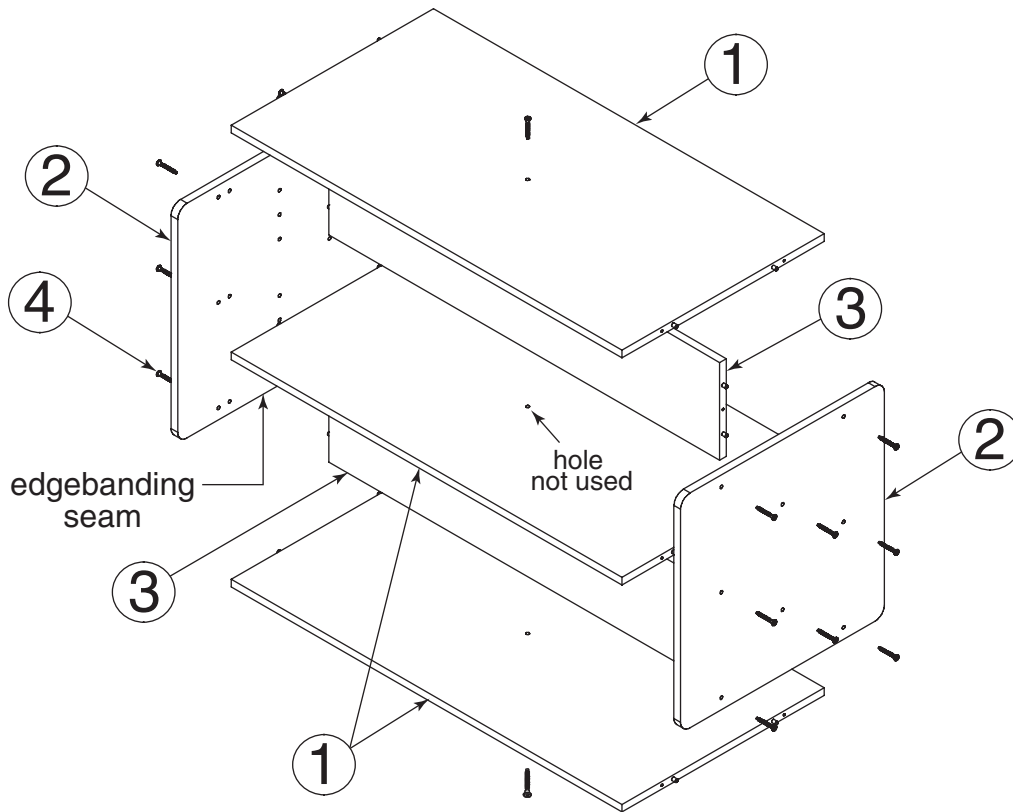
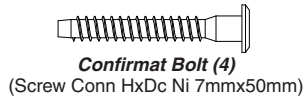

TM2224R Parts List				
ITEM	QTY	PART #	DESCRIPTION	
1	3	51XX-1278	Top-Bot	
2	2	41XX-1479	End U	
3	2	71XX-0645	Back	
4	18	0861-0203000000	Screw Conn HxDc Ni 7mmx 50mm	



**STEP-BY-STEP ASSEMBLY**

**STEP 1**

Lay one **End (2)** flat on floor, with side having the most holes facing up. **IMPORTANT: Edgebanding seam must be on the bottom of the unit when assembly is complete.**

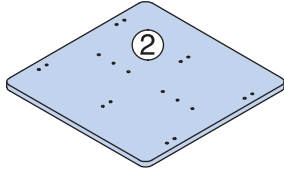

**STEP 2**

Insert dowels on **Top-Bottoms (1)** into the upper, lower and center sets of holes on **End (2)**. Press firmly into place.

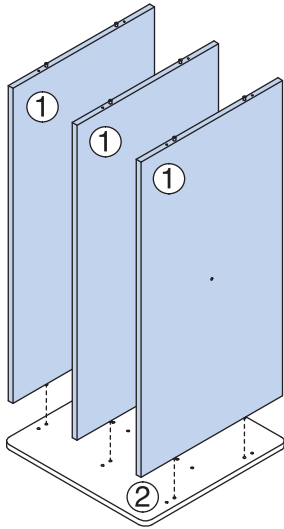

**STEP 3**

Insert dowels on **Backs (3)** into the remaining holes on **End (2)**, between **Top-Bottoms (1)**. Press firmly into place.

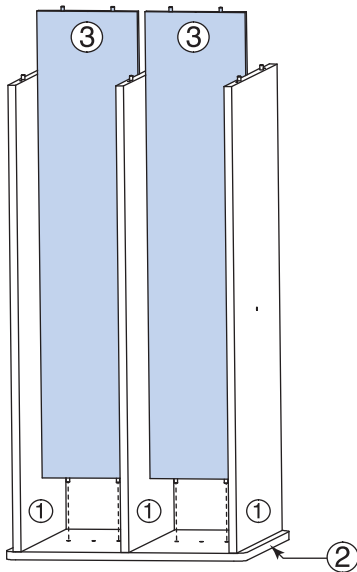

**STEP 4**

Position other **End (2)** on top of assembly, so dowels on **Top-Bottoms (1)** and **Backs (3)** align with holes on **End (2)**. Make sure edgebanding seam on **End (2)** is facing bottom of unit. **Edgebanding seam on both Ends (2) must be facing same direction.** Press firmly into place.

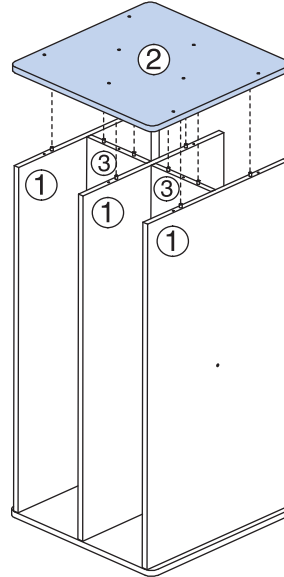

**STEP 5**

Secure **End (2)** to **Top-Bottoms (1)** and **Backs (3)** with eight **Confirmat Bolts (4)**, using the included **Hex Wrench**.

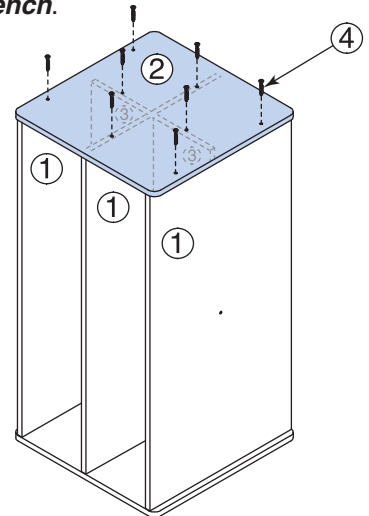



# STEP-BY-STEP ASSEMBLY

**STEP 6** Secure upper and lower **Top-Bottoms (1)** to **Backs (3)** with two **Confirmat Bolts (4)**.

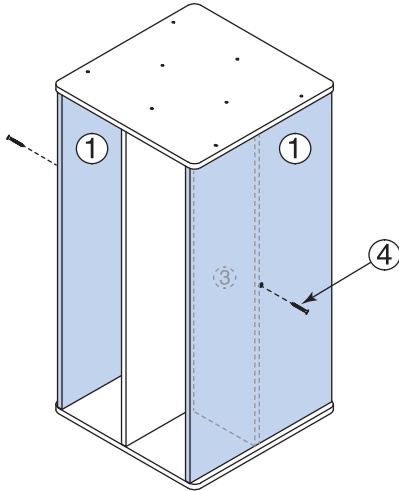

**STEP 7** Carefully turn unit over, so other **End (2)** is facing up.

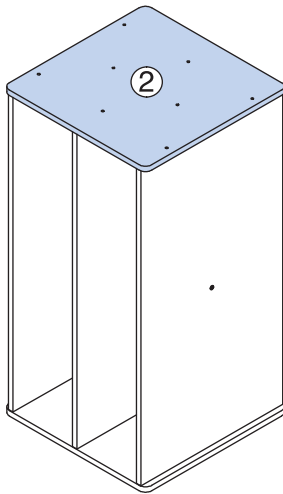

**STEP 8** Repeat **Step 5** to secure **End (2)** to **Top-Bottoms (1)** and **Backs (3)**.

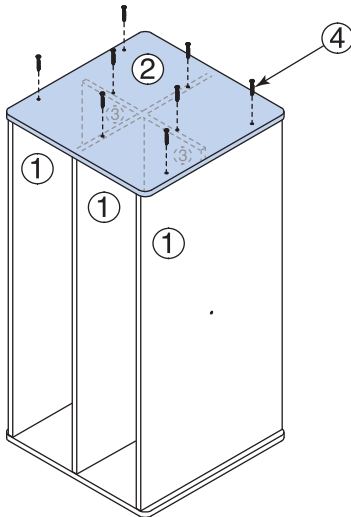

**STEP 9** Carefully stand unit upright. Make sure edgebanding seams on **Ends (2)** are on bottom of unit.

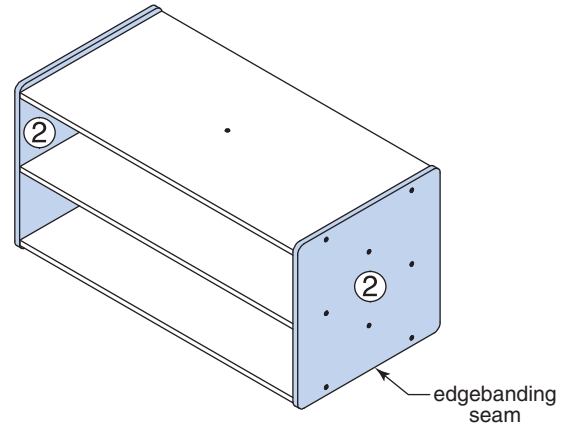

**STEP 10** Ensure that all joints and bolts are tight.

*This completes the assembly.*