



by Stevens Industries, Inc.
 704 West Main St.
 Teutopolis, IL 62467
 P: 800.350.3270
 P: 217-857-7100 • F: 217-857-7101
 www.totmate.com

TM2182R

ATTENTION

Please unpack and assemble in an area away from children's activities. Remove all tools and excess materials from work area after assembly of unit is complete. Dispose of pallet and packaging materials in an environmentally friendly manner. If any parts are missing or damaged, please call Stevens for immediate parts replacement (1-800-350-3270).
 When ordering parts, give the Model Number and Color of the unit.



CAUTION – CHOKING HAZARD

Adult assembly required due to presence of small parts and sharp edges.



TM2182R
Toddler Play Center

Parts List				
ITEM	QTY	PART #	DESCRIPTION	
1	2	41XX-1468	End U	
2	2	51XX-1266	Fxd Shelf	
3	1	31XX-0123	Top	
4	2	61XX-0629	Rail Fr-Ba	
5	16	0861-0203000000	Screw Conn HxDc Ni 7mmx 50mm	

2-PERSON ASSEMBLY RECOMMENDED.

IMPORTANT!

Be sure to keep all parts supported during assembly to avoid damage. Do not over-tighten screws or it will damage the pre-drilled holes; snug fit is adequate.

HARDWARE / TOOLS INCLUDED

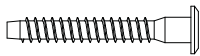

Confirmat Bolt (5)
 (Screw Conn HxDc Ni 7mmx50mm)



Hex Wrench

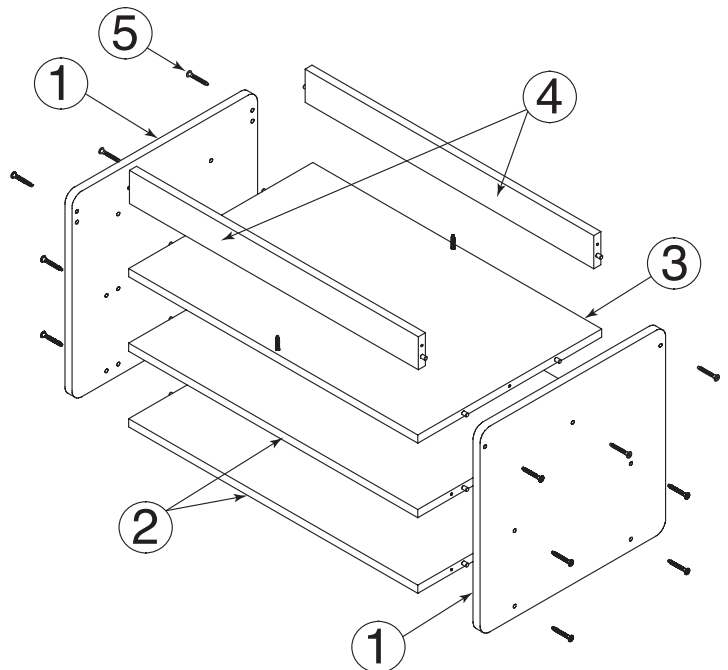



STEP-BY-STEP ASSEMBLY

2-PERSON ASSEMBLY RECOMMENDED.

IMPORTANT!

Be sure to keep all parts supported during assembly to avoid damage. Do not over-tighten screws or it will damage the pre-drilled holes; snug fit is adequate.

STEP 1

Lay one **End (1)** flat on floor, with side having the most holes facing up.

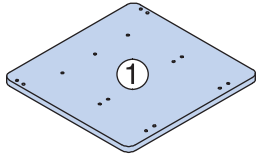

STEP 2

Insert dowels on one **Fixed Shelf (2)** into holes at bottom of **End (1)**. Press firmly into place. Repeat with other **Fixed Shelf (2)**, using holes in middle of **End (1)**.

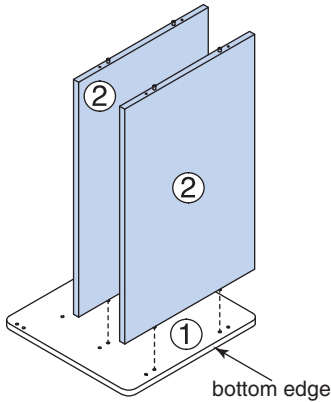

STEP 3

Insert dowels on **Top (3)** into remaining holes on **End (1)**. Make sure side of **Top (3)** with holes is facing toward top edge of unit. Press firmly into place.

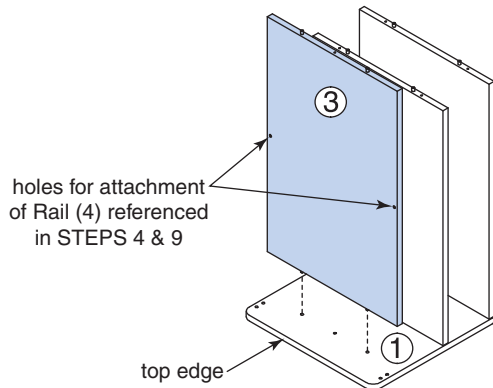

STEP 4

Insert dowel on one **Rail (4)** into lower hole at top of **End (1)**. Ensure hole on bottom edge of **Rail (4)** aligns with thru-hole in **Top (3)** (reference **STEP 3 illustration**). Press firmly into place. Repeat for other **Rail (4)**.

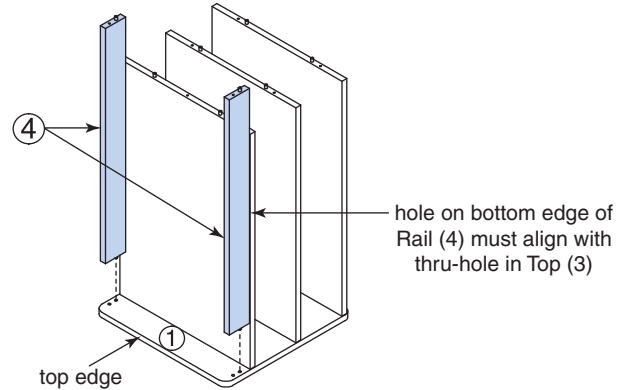

STEP 5

Position other **End (1)** on top of assembly, so dowels on **Rails (4)**, **Top (3)** and **Fixed Shelves (2)** align with holes on **End (1)**. Press firmly into place.

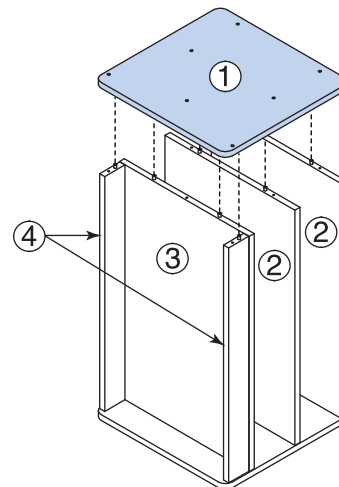



STEP-BY-STEP ASSEMBLY

STEP 6 Secure **End (1)** to **Rails (4)**, **Top (3)** and **Fixed Shelves (2)** with seven **Confirmat Bolts (5)**, using the included **Hex Wrench**.

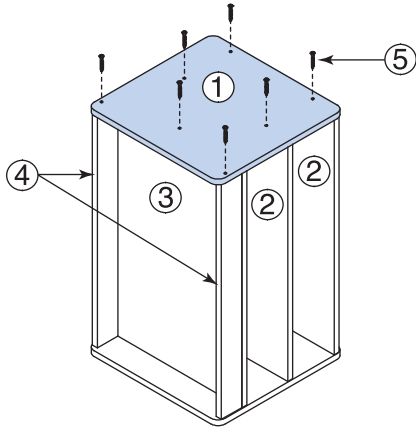

STEP 7 Carefully turn unit over, so other **End (1)** is facing up.

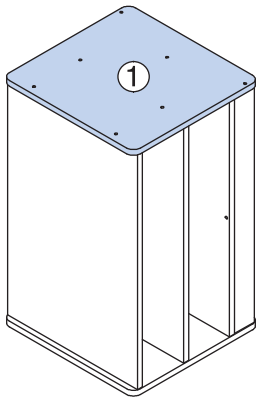

STEP 8 Repeat **Step 6** to secure **End (1)** to **Rails (4)**, **Top (3)** and **Fixed Shelves (2)**.

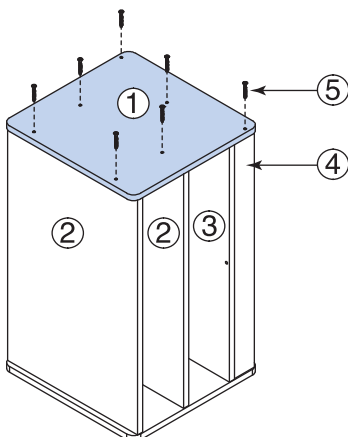

STEP 9 Secure **Top (3)** to **Rails (4)** with two **Confirmat Bolts (5)**.

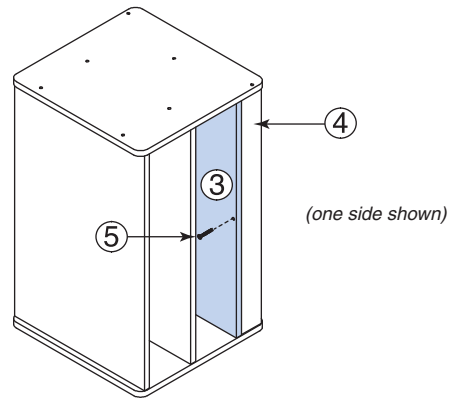

STEP 10 Carefully stand unit upright.

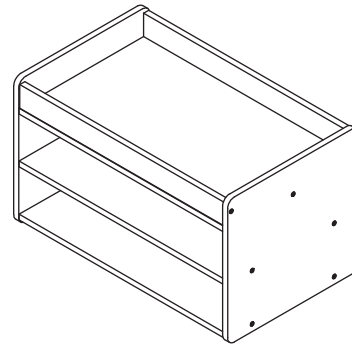

STEP 11 Ensure that all joints and bolts are tight.

This completes the assembly.