



by Stevens Industries, Inc.  
 704 West Main St.  
 Teutopolis, IL 62467  
 P: 800.350.3270  
 P: 217-857-7100 • F: 217-857-7101  
 www.totmate.com

**TM2125R**  
**TM2127R**  
**TM2128R**

**ATTENTION**

Please unpack and assemble in an area away from children's activities. Remove all tools and excess materials from work area after assembly of unit is complete. Dispose of pallet and packaging materials in an environmentally friendly manner. If any parts are missing or damaged, please call Stevens for immediate parts replacement (1-800-350-3270). When ordering parts, give the Model Number and Color of the unit.



**CAUTION – CHOKING HAZARD**

Adult assembly required due to presence of small parts and sharp edges.

**NOTE: ASSEMBLY INSTRUCTIONS REFERENCE ILLUSTRATIONS AND PART NUMBERS FOR THE TM2125R.**



**TM2125R**  
**Toddler Play Center**

Parts List			
ITEM	QTY	PART #	DESCRIPTION
1	2	41XX-1464	End U
2	1	31XX-0120	Top
3	1	51XX-1264	Bottom
4	1	61XX-0627	Rail Support
5	4	0063-0320000000	Gear Block Totmate Red 7x7
6	2	0063-1426000000	Lego Plate Large Gray LGP50x50
7	2	0663-0617000000	Tray Clear 6in F/2 SA911
8	10	0861-0203000000	Screw Conn HxDc Ni 7mmx 50mm



**TM2127R**  
**Preschool Play Center**

Parts List			
ITEM	QTY	PART #	DESCRIPTION
1	1	31XX-0120	Top
2	1	51XX-1264	Bottom
3	1	61XX-0627	Rail Support
6	2	41XX-1463	End U
8	2	0063-1426000000	Lego Plate Large Gray LGP50x50
9	2	0663-0617000000	Tray Clear 6in F/2 SA911
10	10	0861-0203000000	Screw Conn HxDc Ni 7mmx 50mm
11	4	0063-0320000000	Gear Block Totmate Red 7x7



**TM2128R**  
**Preschool Play Center**

Parts List			
ITEM	QTY	PART #	DESCRIPTION
1	1	31XX-0119	Top
2	1	51XX-1263	Bottom
3	2	41XX-1463	End U
4	1	61XX-0625	Rail Support
15	2	0063-1426000000	Lego Plate Large Gray LGP50x50
16	3	0663-0617000000	Tray Clear 6in F/2 SA911
17	10	0861-0203000000	Screw Conn HxDc Ni 7mmx 50mm
18	4	0063-0320000000	Gear Block Totmate Red 7x7



# TM2125R – TM2127R – TM2128R

## STEP-BY-STEP ASSEMBLY

ILLUSTRATIONS AND PART NUMBERS ARE FOR TM2125R.  
 BASIC ASSEMBLY INSTRUCTIONS ARE THE SAME FOR ALL 3 MODELS.  
 2-PERSON ASSEMBLY RECOMMENDED.

### IMPORTANT!

*Be sure to keep all parts supported during assembly to avoid damage.  
 Do not over-tighten screws or it will damage the pre-drilled holes;  
 snug fit is adequate.*

### HARDWARE / TOOLS INCLUDED

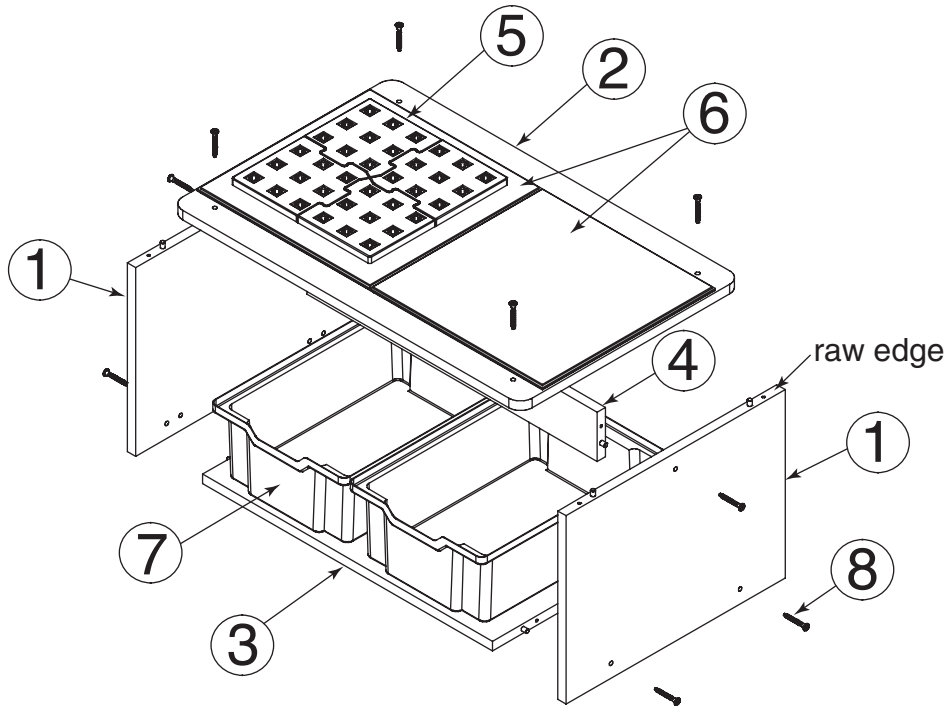
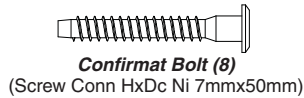

TM2125R Parts List			
ITEM	QTY	PART #	DESCRIPTION
1	2	41XX-1464	End U
2	1	31XX-0120	Top
3	1	51XX-1264	Bottom
4	1	61XX-0627	Rail Support
5	4	0063-0320000000	Gear Block Totmate Red 7x7
6	2	0063-1426000000	Lego Plate Large Gray LGP50x50
7	2	0663-0617000000	Tray Clear 6in F/2 SA911
8	10	0861-0203000000	Screw Conn HxDc Ni 7mmx 50mm



**STEP-BY-STEP ASSEMBLY**

**STEP 1**

Lay one **End (1)** flat on floor, with side having the most holes facing up. (NOTE: Raw edge is top edge.)

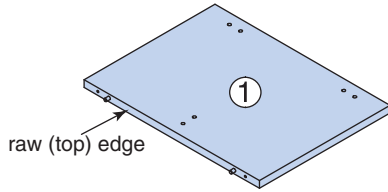

**STEP 2**

Insert dowel on **Rail Support (4)** into lower hole at top of **End (1)**. Press firmly into place.

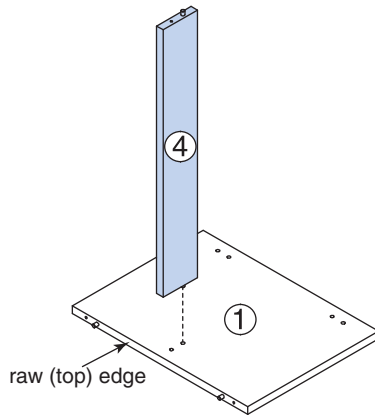

**STEP 3**

Insert dowels on one end of **Bottom (3)** into remaining holes on **End (1)**. Press firmly into place.

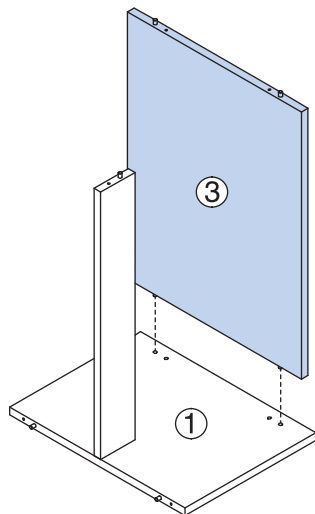

**STEP 4**

Position other **End (1)** on top of assembly, so dowels on **Rail Support (4)** and **Bottom (3)** align with holes on **End (1)**. Press firmly into place.

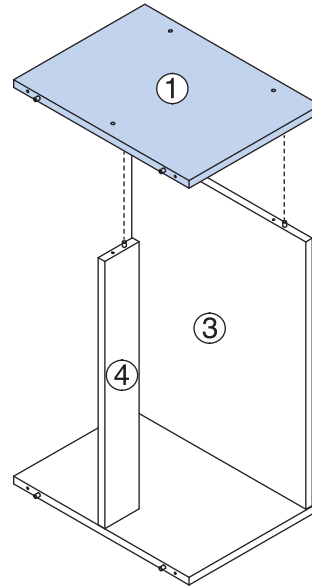

**STEP 5**

Secure **End (1)** to **Rail Support (4)** and **Bottom (3)** with three **Confirmat Bolts (8)**, using the included **Hex Wrench**.

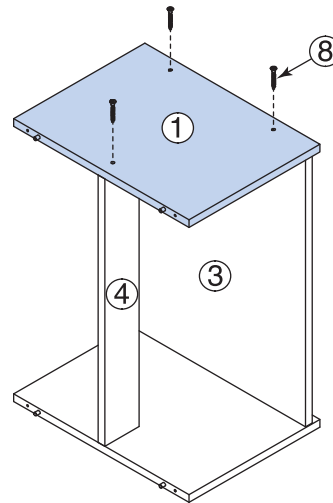

**STEP 6**

Carefully turn unit over, so other **End (1)** is facing up.



STEP-BY-STEP ASSEMBLY

STEP 7

Repeat **Step 5** to secure other **End (1)** to **Rail Support (4)** and **Bottom (3)**.

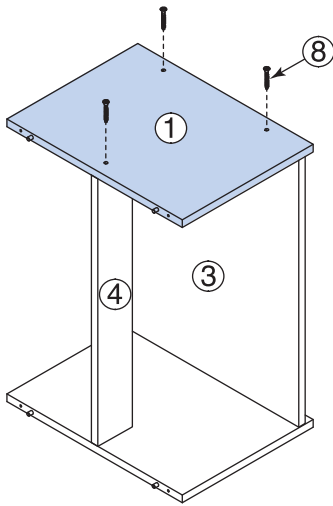

STEP 8

Carefully stand unit upright and align holes on bottom side of **Top (2)** with dowels on top edge of **Ends (1)**, making sure the pre-installed **Lego Plates (6)** are facing up. Press **Top (2)** firmly into place.

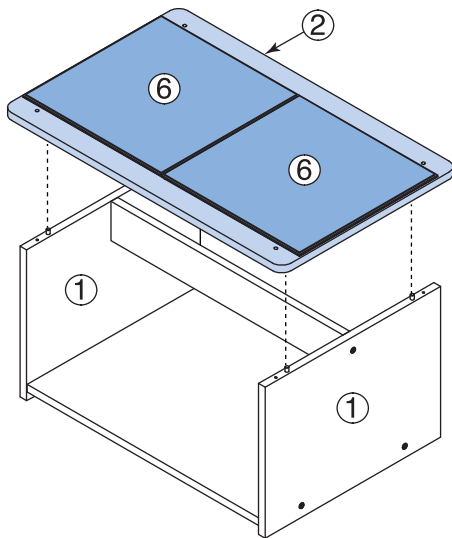

STEP 9

Secure **Top (2)** to **Ends (1)** with four **Confirmat Bolts (8)**.

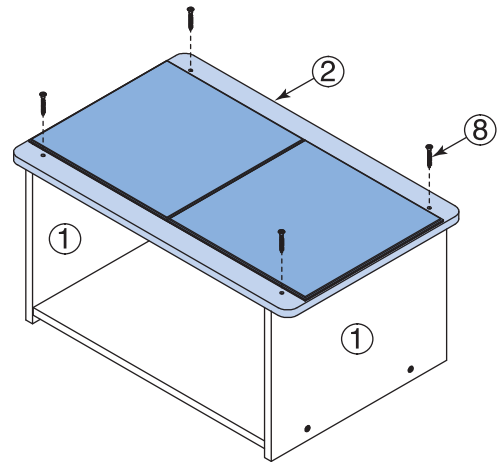

STEP 10

The 4-piece **Gear Block Grid (5)** fits onto the **Lego Plates (6)**, or can be set aside for later use. **Trays (7)** are included for storage on lower shelf.

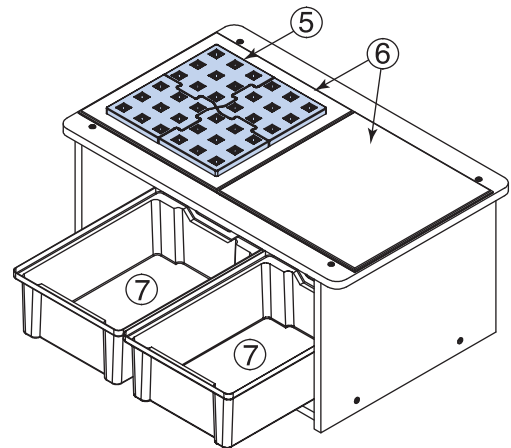

STEP 11

Ensure that all joints and bolts are tight.

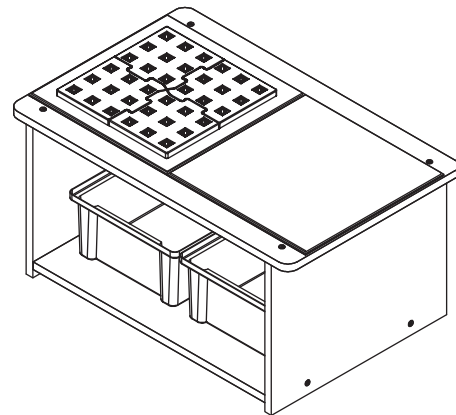

*This completes the assembly.*