

FinishPro™ HVLP 7.0/9.0/9.5

3A4967E
EN

*For professional use only. For portable spray applications of fine finish coatings.
Not approved for use in explosive atmospheres or hazardous locations.*

FinishPro HVLP 7.0/9.0 Standard
FinishPro HVLP 7.0/9.0/9.5 ProContractor
FinishPro HVLP 9.5 ProComp
See page 3 for additional model information

10 psi (0.07 MPa, 0.7 bar) Maximum Working Pressure
ProComp Models: 50 psi (0.35MPa, 3.5 bar) Maximum Fluid Working Pressure



Important Safety Instructions

Read all warnings and instructions in this manual and in related manuals.
Be familiar with the controls and the proper usage of the equipment.
Save these instructions.

Related Manuals:

3A4980	Gun
--------	-----

WARNING

FIRE AND EXPLOSION HAZARD

- The turbine motor generates sparks. Keep sprayer at least 20 feet (6m) from spray area. Use additional hose if necessary.
- Spraying flammable or combustible materials in a factory or fixed location must comply with NFPA 33 and OSHA 1910.94(c) requirements in the USA and with all similar local regulations in other countries.

SERVICE
to every customer, every time

www.graco.com/techsupport

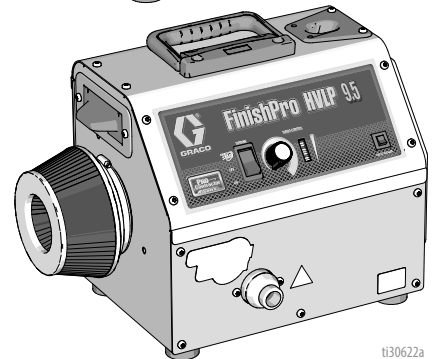
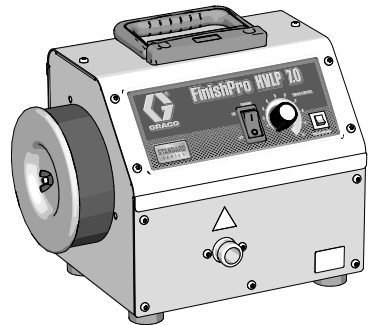

t130622a

Table of Contents



Table of Contents

Models	3
Key Features	3
Warnings	4
Know Your Sprayer	7
Standard Models	7
ProContractor Models	8
ProComp Models	9
Pressure Relief Procedure	10
Setup	11
Fluid and Work Piece Preparation	12
Fluid Set Selection	12
Startup	13
Fill FlexLiner System	13
Fill Remote Cup (ProComp Models only)	14
Startup	16
Cup Over Installation	17
How to Spray	19
Spray Techniques	19
Triggering Gun	19
Aiming Gun	20
Refilling FlexLiner	20
Refilling Remote Cup	20
Cleanup	21
Troubleshooting	27
Parts	30
Standard Models	30
Parts List - Standard Models	31
Parts	32
ProContractor Models	32
Parts List - ProContractor Models	33
Parts	34
ProComp Models	34
Parts List - ProComp Models	35
Parts - Power Cords & Accessories	36
Parts List - Power Cords & Accessories	37
Wiring Diagrams (Standard)	38
Wiring Diagrams (Standard)	39
Wiring Diagrams (ProContractor)	40
Wiring Diagrams (ProComp)	41
Technical Specifications	42
Graco Standard Warranty	46
Graco Information	47

Models

Key Features

TurboControl - Not available on all models	<ul style="list-style-type: none"> • Allows user to adjust sprayer performance to match application needs. • Use at lowest setting that provides desired finish. • Reduces heat buildup and job site noise.
SmartStart - Available only on ProContractor and ProComp models	<ul style="list-style-type: none"> • Sprayer automatically turns off after no spraying activity; trigger gun to re-start sprayer. • Reduces heat buildup and job site noise. • Turn switch to ON if SmartStart is not desired.
FlexLiner System - Not available on all models	<ul style="list-style-type: none"> • Allows user to spray gun at any angle without cup adjustment. • Reduces cleaning time with no siphon tube and disposable liner. • Quick change cup connection.

	VAC	Model	Part Number	Hose			Spray Gun		Fluid Sets		
				20-ft	30-ft	4-ft Whip	Edge II	Edge II Plus	#3	#4	#5
	120 USA	7.0 Standard	17U105								
		7.0 Standard	17N263	✓			✓		✓		
		9.0 Standard	17N264	✓			✓		✓		
		7.0 ProContractor	17N265		✓			✓	✓		
		9.0 ProContractor	17N266		✓			✓	✓	✓	
		9.5 ProContractor	17N267		✓	✓		✓	✓	✓	✓
		9.5 ProComp	17N269		✓	✓		✓*	✓	✓	✓
	230 CEE 77	7.0 Standard	17P528	✓			✓		✓		
		7.0 Standard	17T980	✓			✓		✓		
		9.0 Standard	17P529	✓			✓		✓		
		7.0 ProContractor	17P530		✓	✓		✓	✓		
		9.0 ProContractor	17P531		✓	✓		✓	✓	✓	
		9.5 ProContractor	17P532		✓	✓		✓	✓	✓	✓
		9.5 ProContractor	17T982		✓	✓		✓	✓	✓	✓
	9.5 ProComp	17P533		✓	✓		✓*	✓	✓	✓	
	230 Europe Multi / UK	7.0 Standard	17P534	✓			✓		✓		
		9.0 Standard	17P535	✓			✓		✓		
		7.0 ProContractor	17P536		✓	✓		✓	✓		
		9.0 ProContractor	17P537		✓	✓		✓	✓	✓	
		9.5 ProContractor	17P538		✓	✓		✓	✓	✓	✓
		9.5 ProComp	17P539		✓	✓		✓*	✓	✓	✓
		230 Asia / ANZ / SCA	7.0 Standard	17R074	✓			✓		✓	
	9.0 Standard		17R075	✓			✓		✓		
	7.0 ProContractor		17R078		✓			✓	✓		
	9.0 ProContractor		17R079		✓			✓	✓	✓	
	9.5 ProContractor		17R080		✓	✓		✓	✓	✓	✓
	9.5 ProComp		17R081		✓	✓		✓*	✓	✓	✓

*ProComp Models - Edge II Plus spray gun for remote cup. FlexLiner System Conversion Kit included.

Warnings

The following warnings are for the setup, use, grounding, maintenance, and repair of this equipment. The exclamation point symbol alerts you to a general warning and the hazard symbols refer to procedure-specific risks. When these symbols appear in the body of this manual or on warning labels, refer back to these Warnings. Product-specific hazard symbols and warnings not covered in this section may appear throughout the body of this manual where applicable.

WARNING



GROUNDING

This product must be grounded. In the event of an electrical short circuit, grounding reduces the risk of electric shock by providing an escape wire for the electric current. This product is equipped with a cord having a grounding wire with an appropriate grounding plug. The plug must be plugged into an outlet that is properly installed and grounded in accordance with all local codes and ordinances.

- Improper installation of the grounding plug is able to result in a risk of electric shock.
- When repair or replacement of the cord or plug is required, do not connect the grounding wire to either flat blade terminal.
- The wire with insulation having an outer surface that is green with or without yellow stripes is the grounding wire.
- Check with a qualified electrician or serviceman when the grounding instructions are not completely understood, or when in doubt as to whether the product is properly grounded.
- Do not modify the plug provided; if it does not fit the outlet, have the proper outlet installed by a qualified electrician.
- This product is for use on a nominal 120V or 230V circuit and has a grounding plug similar to the plugs illustrated below.

120V US

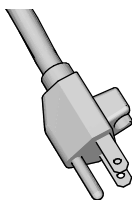

230V

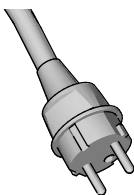

230V ANZ



ti24583b

- Only connect the product to an outlet having the same configuration as the plug.
- Do not use an adapter with this product.

Extension Cords:

- Use only a 3-wire extension cord that has a grounding plug and a grounding receptacle that accepts the plug on the product.
- Make sure your extension cord is not damaged. If an extension cord is necessary use 12 AWG (2.5mm²) minimum, 50 ft maximum length, to carry the current that the product draws.
- An undersized cord results in a drop in line voltage and loss of power and overheating.

WARNING



FIRE AND EXPLOSION HAZARD

Flammable fumes, such as solvent and paint fumes, in work area can ignite or explode. To help prevent fire and explosion:



- Do not spray flammable or combustible materials near an open flame or sources of ignition such as cigarettes, motors, electrical equipment, and plastic drop cloths (potential static sparking).
- Turbine motor generates sparks. Keep sprayer in a well ventilated area at least 20 feet (6 m) from the spray area when spraying, flushing, cleaning, or servicing. Do not spray pump assembly.
- Connect to a grounded outlet and use grounded extensions cords. Do not use a 3-to-2 adapter.
- Do not use a paint or a solvent containing halogenated hydrocarbons.
- Do not spray flammable or combustible liquids in a confined area.
- Keep spray area well-ventilated. Keep a good supply of fresh air moving through the area.
- Do not smoke in the spray area or spray where sparks or flame is present.
- Do not operate light switches, engines, or similar spark producing products in the spray area.
- Keep area clean and free of paint or solvent containers, rags, and other flammable materials.
- Know the contents of the paints and solvents being sprayed. Read all Safety Data Sheets (SDSs) and container labels provided with the paints and solvents. Follow the paint and solvents manufacturer's safety instructions.
- Keep a working fire extinguisher in the work area.



ELECTRIC SHOCK HAZARD

This equipment must be grounded. Improper grounding, setup, or usage of the system can cause electric shock.



- Turn off and disconnect power cord before servicing equipment.
- Connect only to grounded electrical outlets.
- Use only 3-wire extension cords.
- Ensure ground prongs are intact on power and extension cords.
- Do not expose to rain. Store indoors.



PRESSURIZED EQUIPMENT HAZARD

Fluid from the equipment, leaks, or ruptured components can splash in the eyes or on skin and cause serious injury.



- Follow the **Pressure Relief Procedure** when you stop spraying/dispensing and before cleaning, checking, or servicing equipment.
- Tighten all fluid connections before operating the equipment.
- Check hoses, tubes, and couplings daily. Replace worn or damaged parts immediately.

Warnings

WARNING



EQUIPMENT MISUSE HAZARD

Misuse can cause death or serious injury.

- Always wear appropriate gloves, eye protection, and a respirator or mask when painting.
- Do not operate or spray near children. Keep children away from equipment at all times.
- Do not overreach or stand on an unstable support. Keep effective footing and balance at all times.
- Stay alert and watch what you are doing.
- Do not operate the unit when fatigued or under the influence of drugs or alcohol.
- Do not kink or over-bend the hose.
- Do not expose the hose to temperatures or to pressures in excess of those specified by Graco.
- Do not use the hose as a strength member to pull or lift the equipment.
- Do not alter or modify equipment. Alterations or modifications may void agency approvals and create safety hazards.
- Make sure all equipment is rated and approved for the environment in which you are using it.



PRESSURIZED ALUMINUM PARTS HAZARD

Use of fluids that are incompatible with aluminum in pressurized equipment can cause serious chemical reaction and equipment rupture. Failure to follow this warning can result in death, serious injury, or property damage.

- Do not use 1,1,1-trichloroethane, methylene chloride, other halogenated hydrocarbon solvents or fluids containing such solvents.
- Do not use chlorine bleach.
- Many other fluids may contain chemicals that can react with aluminum. Contact your material supplier for compatibility.



TOXIC FLUID OR FUMES HAZARD

Toxic fluids or fumes can cause serious injury or death if splashed in the eyes or on skin, inhaled, or swallowed.

- Read SDSs to know the specific hazards of the fluids you are using.
- Store hazardous fluid in approved containers, and dispose of it according to applicable guidelines.



PERSONAL PROTECTIVE EQUIPMENT

Wear appropriate protective equipment when in the work area to help prevent serious injury, including eye injury, hearing loss, inhalation of toxic fumes, and burns. This protective equipment includes but is not limited to:

- Protective eyewear, and hearing protection.
- Respirators, protective clothing, and gloves as recommended by the fluid and solvent manufacturer.

CALIFORNIA PROPOSITION 65

This product contains a chemical known to the State of California to cause cancer, birth defects or other reproductive harm. Wash hands after handling.

Know Your Sprayer

Standard Models

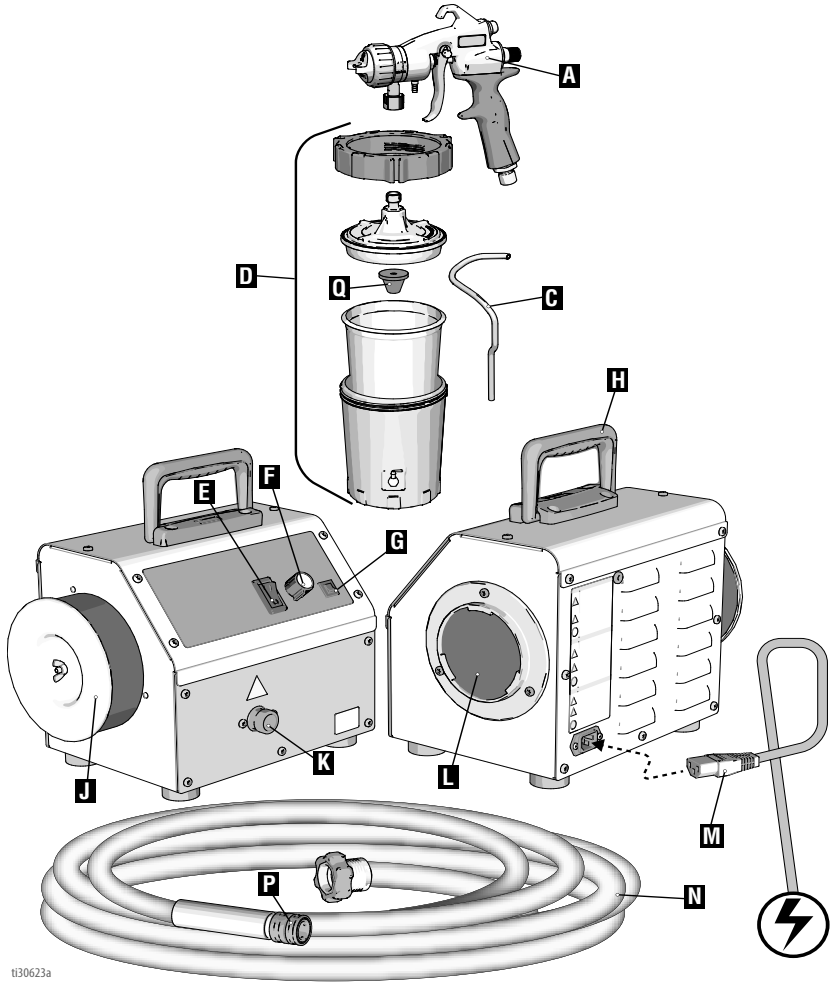

tt30623a

A	Edge II Spray Gun
C	Spray Gun Tubing
D	FlexLiner System
E	ON/OFF Switch
F	TurboControl (select models)
G	Resettable Circuit Breaker
H	Sprayer Handle

J	Turbine Air Filter
K	Air Outlet
L	Motor Air Filter
M	Power Cord
N	Sprayer Air Hose
P	Quick Connect
Q	Material Strainer

Know Your Sprayer

ProContractor Models

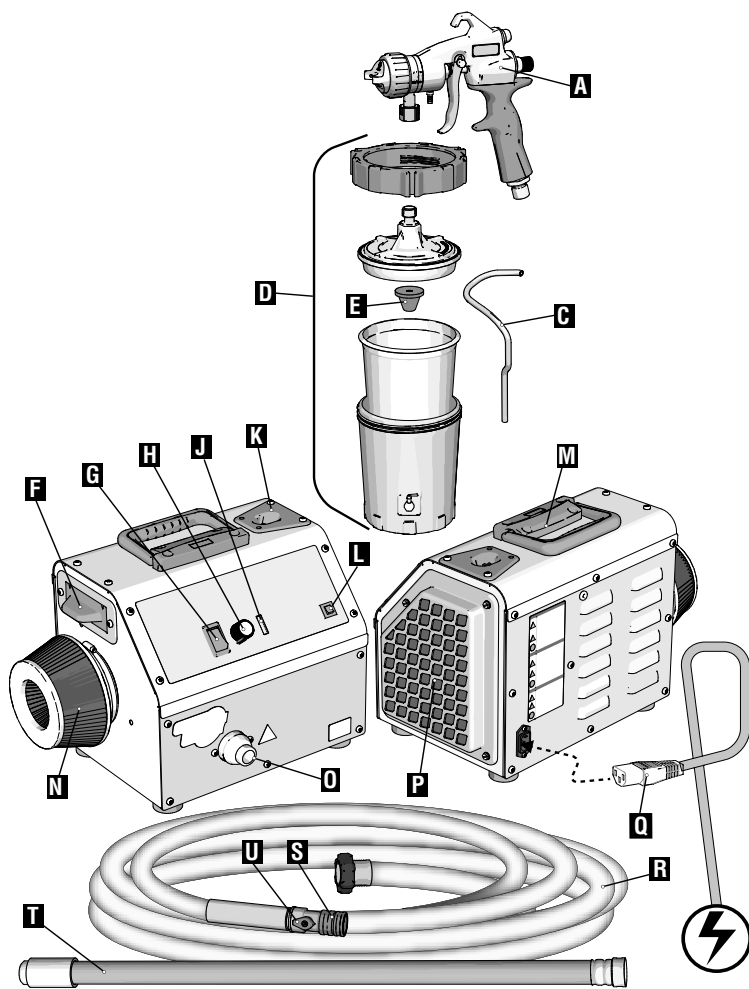

ti30754a

A	Edge II Plus Spray Gun
C	Spray Gun Tubing
D	FlexLiner System
E	Material Strainer
F	Fluid Set Storage
G	ON/OFF/SmartStart Switch
H	TurboControl
J	TurboControl LED Indicator
K	Spray Gun Holder
L	Resettable Circuit Breaker

M	Sprayer Handle
N	Turbine Air Filter
O	Air Outlet
P	Motor Air Filter
Q	Power Cord
R	Sprayer Air Hose
S	Quick Connect
T	Whip Hose (select models)
U	Air Valve

ProComp Models

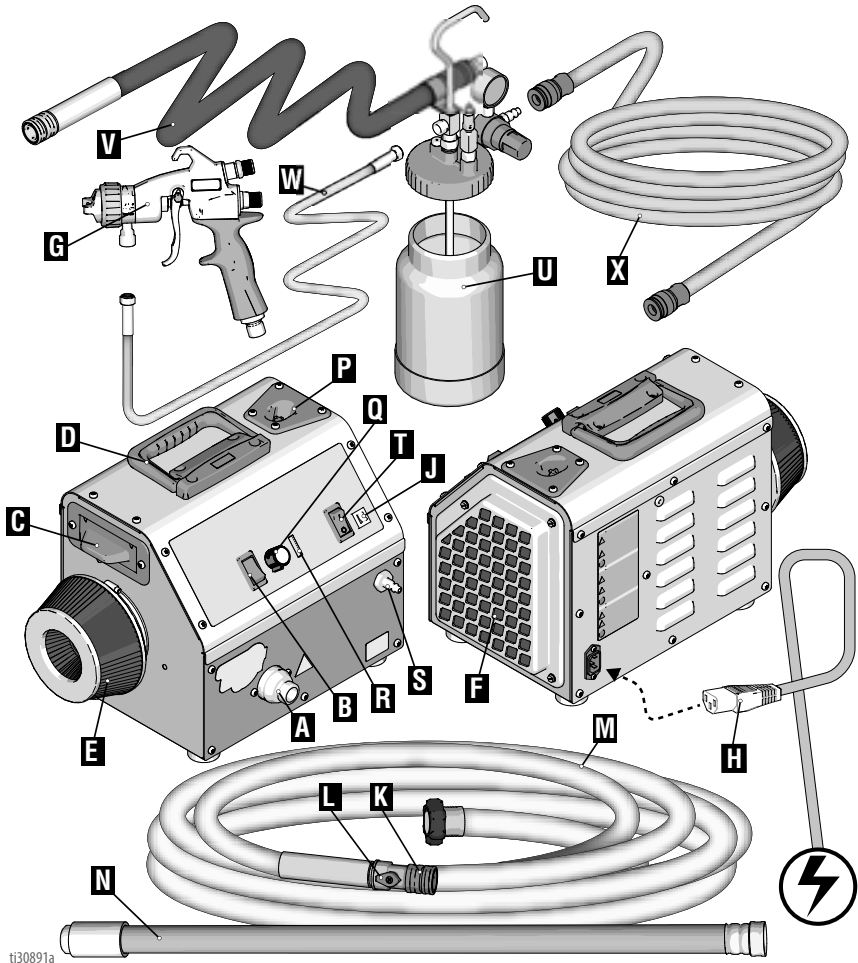

ti30891a

A	Air Outlet
B	ON/OFF/SmartStart Switch
C	Fluid Set Storage
D	Sprayer Handle
E	Turbine Air Filter
F	Motor Air Filter
G	Edge II Plus Spray Gun
H	Power Cord
J	Resettable Circuit Breaker
K	Quick Connect
L	Air Valve

M	Sprayer Air Hose
N	Whip Hose
P	Spray Gun Holder
Q	TurboControl
R	TurboControl LED Indicator
S	Compressor Outlet
T	Compressor ON/OFF Switch
U	Remote Cup, 2-qt
V	Gun Air Hose, 5-ft
W	Remote Cup Fluid Hose, 5-ft
X	Remote Cup Air Hose, clear

Pressure Relief Procedure

Pressure Relief Procedure



Follow the Pressure Relief Procedure whenever you see this symbol.



The spray gun cup is pressurized. To reduce the risk of splashing from pressurized fluid, always follow the **Pressure Relief Procedure** before removing cup.

1. Turn the ON/OFF switch to **OFF** position.

Standard Models:

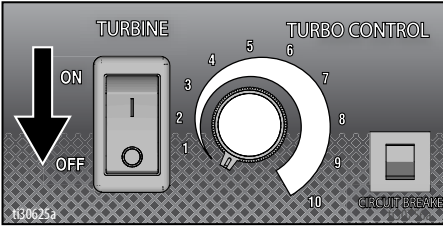

ProContractor and ProComp Models:

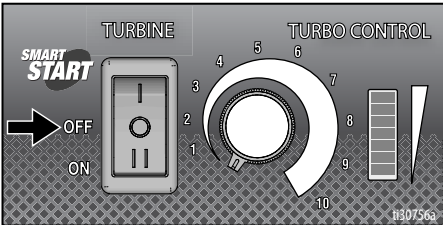

2. Unplug power cord to disconnect power.
3. Disconnect spray gun from air hose.

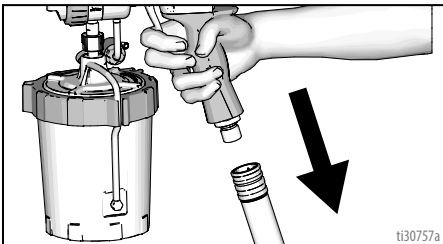

If using a FlexLiner System:

4. Disconnect tubing from gun to relieve pressure in the cup.

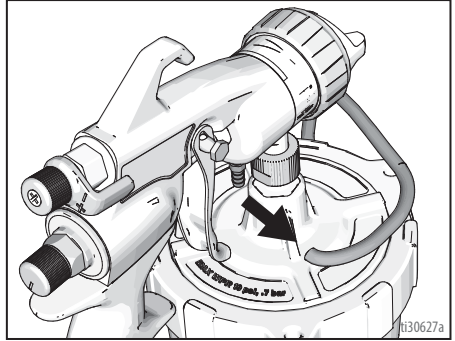

If using a ProComp remote cup:

5. Turn compressor ON/OFF switch to OFF position.

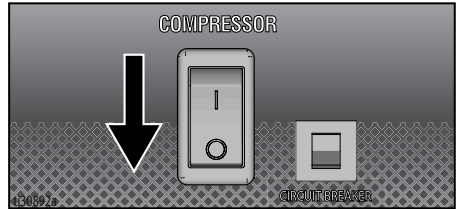

6. Disconnect air hose from remote cup. Turn out pressure regulator one turn. Wait until pressure is completely relieved before removing cover.

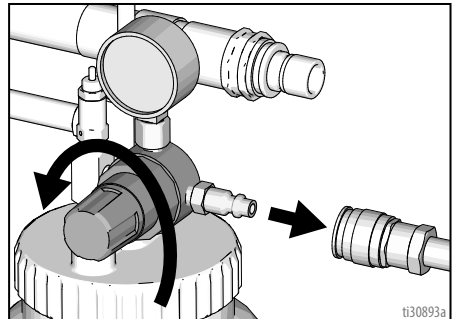

Setup

When unpacking sprayer for the first time or after long term storage, perform setup procedure.

1. Connect air hose to sprayer. Hand tighten.
2. If using a ProComp Model with remote cup:

Connect gun air hose (V) to end of sprayer air hose (M).

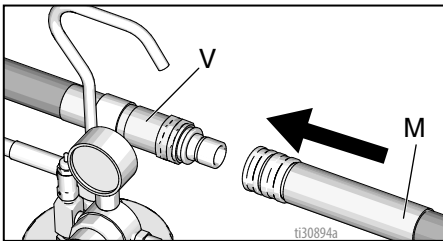

NOTICE

For units with a whip hose, do not connect whip hose directly to sprayer. Connect whip hose to gun end .

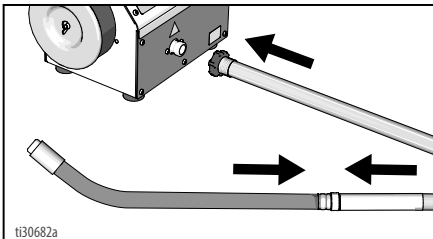

NOTICE

The SmartStart feature on ProContractor and ProComp models relies on an air tight system. Use components provided with sprayer and Edge II Plus gun. Ensure all hose connections are secure to avoid air leakage.

3. Connect power cord to sprayer power connection.

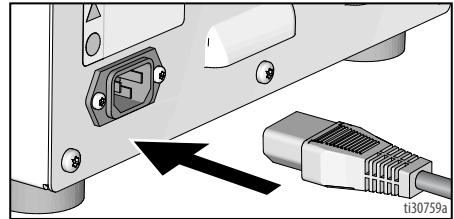

4. Plug sprayer power cord into grounded outlet.

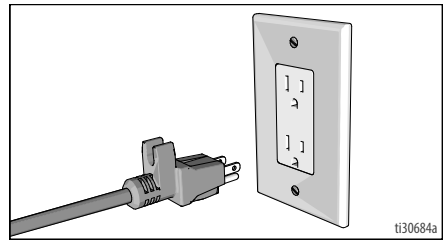

Fluid and Work Piece Preparation

- Strain fluids before spraying. This includes colors, reducers and hardeners.
- Use a slower drying reducer or thinner to compensate for the faster drying time caused by the warm air of the turbine. Do not over reduce.
- Sprayer performance varies with the viscosity of the material sprayed and the length of the hose. To prevent pressure drop, use hose supplied with sprayer.
- Most material manufacturers provide recommendations for their materials. Follow these recommendations.
- For proper adhesion, ensure surface of work piece is completely clean.

Fluid Set Selection

For best spray performance, select proper fluid set for fluid being sprayed. Reference **Fluid Set Selection Guide** in HVLP Edge II gun manual provided with sprayer. Fluid Set numbers are marked on fluid needles and nozzles.

Startup

Fill FlexLiner System

1. Disconnect gun from FlexLiner System.

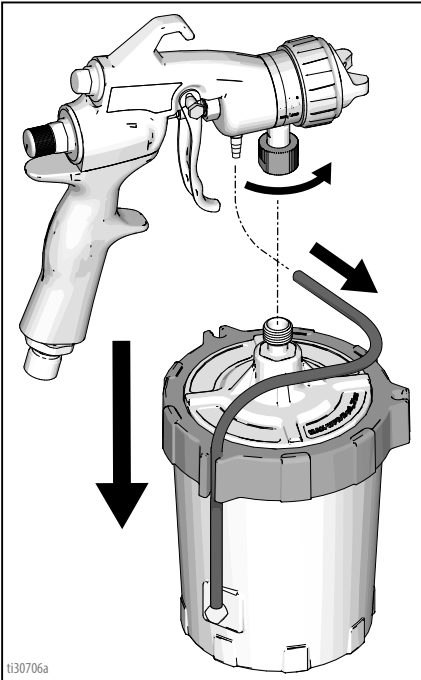

2. Loosen ring from cup. Remove cover and ring from cup. Verify FlexLiner remains in cup upon removal of cover and ring.

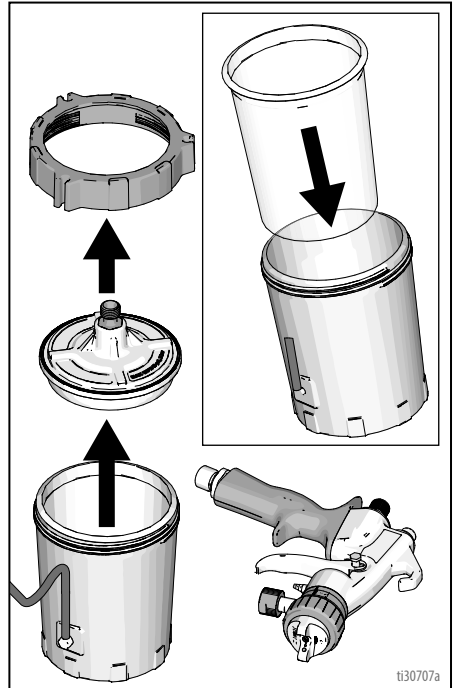

3. Fill FlexLiner with material to "MAX FILL" line. Clean threads and sealing surfaces of FlexLiner System.

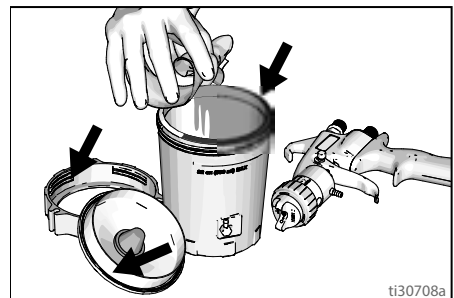

Startup

4. Install cover and ring onto cup. Tighten ring securely.

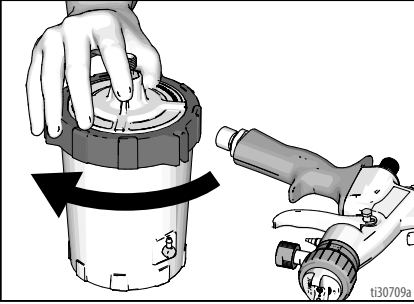

5. Connect FlexLiner System to gun.

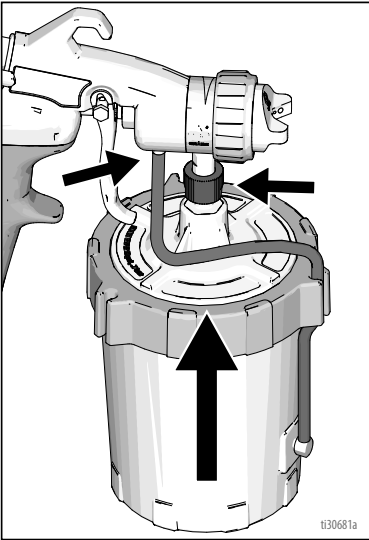

6. Connect air hose to inlet fitting of gun.

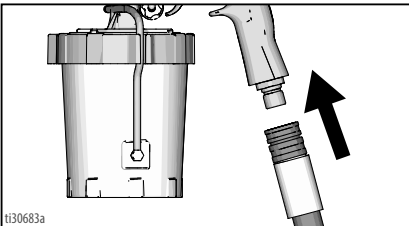

7. You are now ready to spray. Reference **Startup**, page 16, and HVLP Edge II gun manual, provided with sprayer, for spraying instructions.

Fill Remote Cup (ProComp Models only)

1. Fill remote cup 3/4 full and install cover.

NOTICE

Only hand-tighten remote cup cover. Excessive tightening may damage cover gasket.

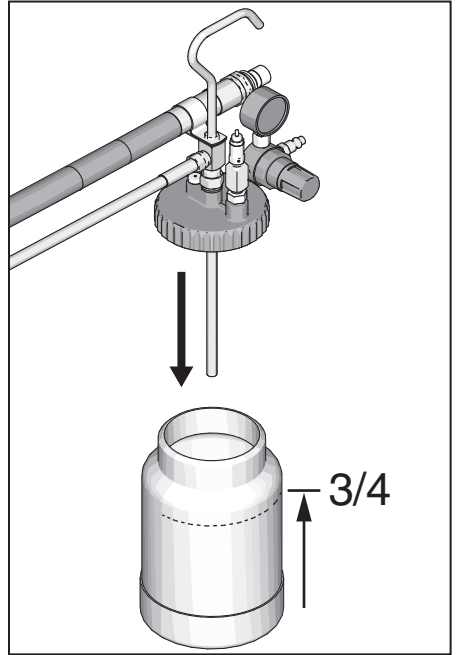

2. Connect clear air hose to compressor outlet and remote cup air inlet.

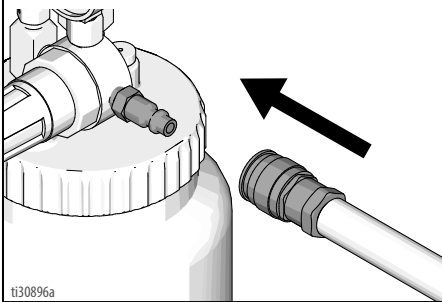
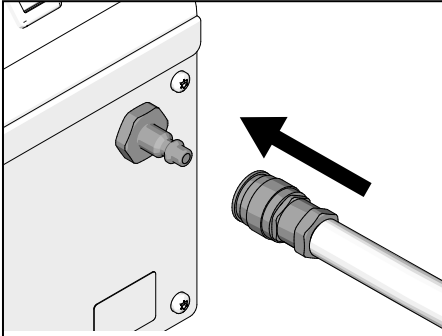

3. Connect 5 ft (1.5 m) fluid hose to remote cup fluid outlet and gun fluid inlet.

NOTE: Gun must be setup for use with remote cup.

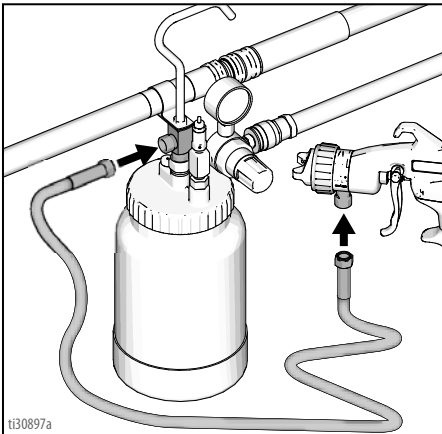

4. Connect air hose (V) to inlet fitting of gun.

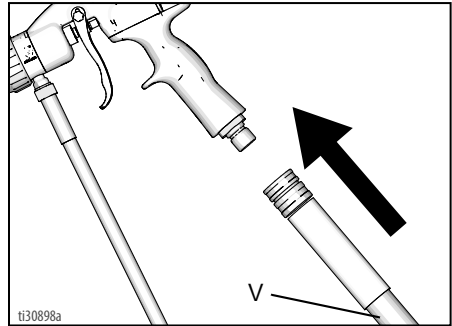

NOTICE

If the remote cup is accidentally tipped over or held at too great of an angle, fluid may leak into air regulator and cause damage. Take precautions to avoid this. If fluid gets into regulator, clean immediately.

5. You are now ready to spray. Reference **Startup**, page 16, and HVLP Edge II gun manual, provided with sprayer, for spraying instructions.

Startup

Startup

TurboControl allows for performance adjustment of the sprayer. To reduce over-spray, always start at lowest setting and increase to the minimum setting required to provide the desired finish.

1. Turn TurboControl to lowest setting.

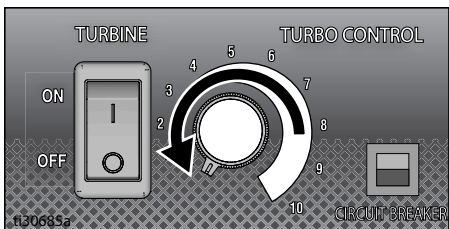

2. Turn ON/OFF switch to ON position.

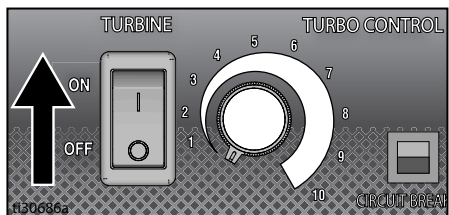

NOTE: ProContractor and ProComp models in SmartStart setting will automatically turn off when not actively spraying. Sprayer will start upon re-triggering of HVLP Edge II Plus gun. Turn switch to ON position if SmartStart is not desired. In ON mode, unit will still shutdown after 3 minutes of non-use. Sprayer will start upon re-triggering of gun.

NOTE: For SmartStart to function, use components provided with sprayer and Edge II Plus gun. For replacement parts, see pages 32-37.

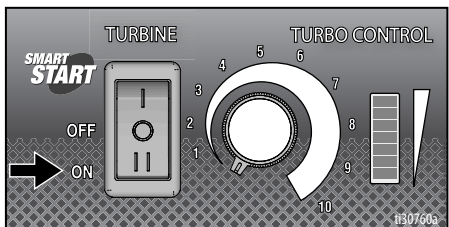

If using FlexLiner System:

3. Point gun into a waste area. Evacuate air from FlexLiner System by holding gun vertically and pull trigger open until a continuous spray pattern is observed.

NOTE: Tilt gun back and forth to help in evacuation of air.

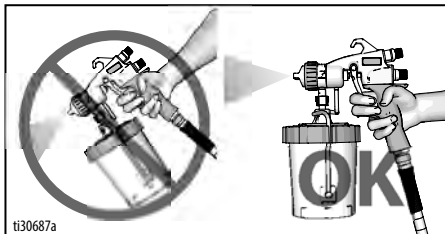

If using remote cup with ProComp Model:

4. Turn pressure regulator to lowest setting.

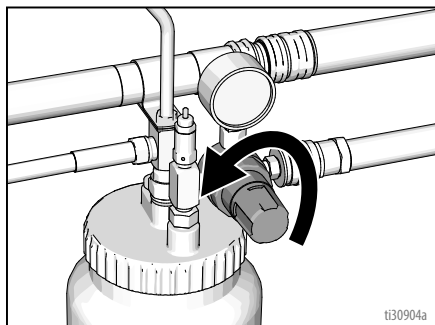

5. Turn compressor ON/OFF switch to ON position.

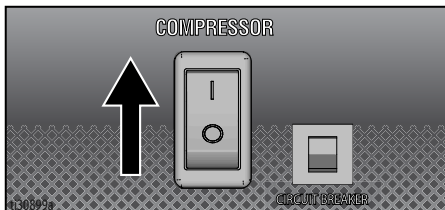

NOTE: If experiencing low remote cup pressure, disconnect clear air hose from compressor outlet (see step 2, page 15) and allow compressor to run for 10 seconds. Reconnect air hose.

Cup Over Installation

1. Perform **Pressure Relief Procedure**, page 10.
2. Disconnect gun from FlexLiner system. Loosen nut on backside of gun. Do not remove nut. Pull nozzle housing assembly out just far enough to allow rotation. Rotate nozzle housing assembly 180° so it faces upward.
3. Loosen nut on backside of gun. Do not remove nut. Pull nozzle housing assembly out just far enough to allow rotation. Rotate nozzle housing assembly 180° so it faces upward.

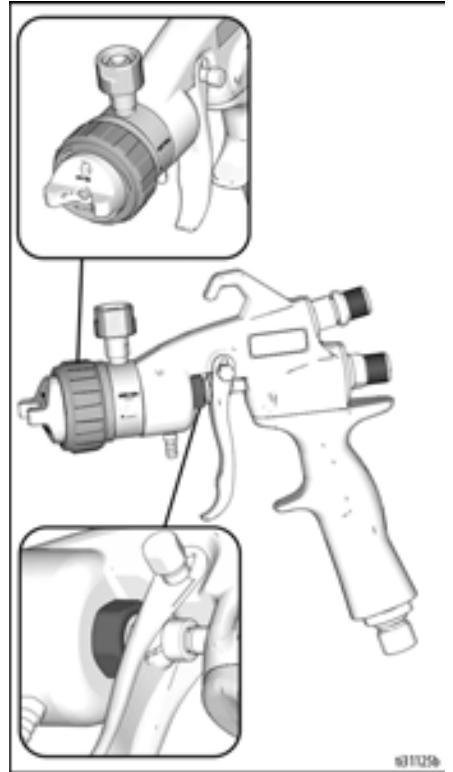
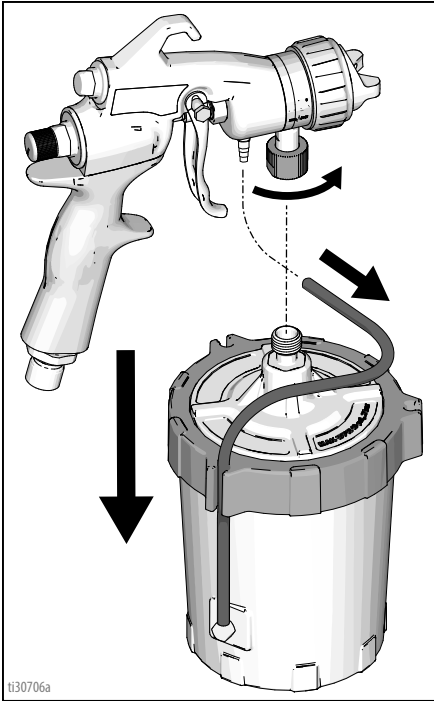

Cup Over Installation

4. Press nozzle housing assembly in, making sure the hole and pin are aligned and housing can no longer rotate.
5. Torque nut to 140-150 in-lb (15.8-16.9 N•m).
6. Reconnect Flexliner system.

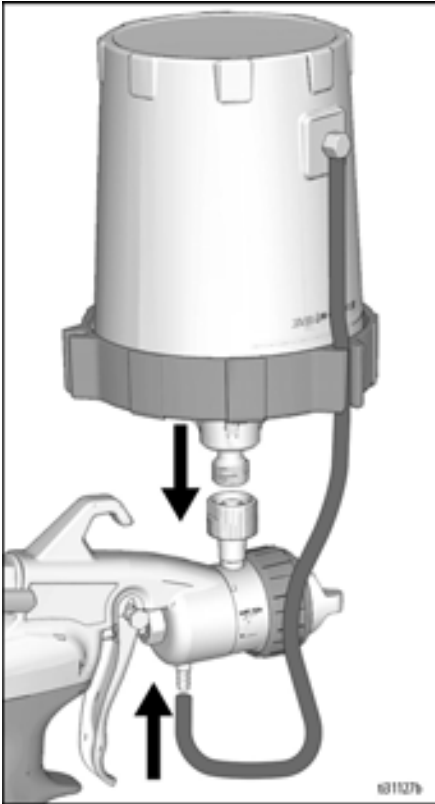

How to Spray



The turbine motor generates sparks. These sparks can ignite flammable fumes.

- Keep sprayer in a well ventilated area.
- Keep sprayer at least 20 feet (6m) from spray area. Use additional hose if necessary.

Take a few moments prior to spraying and review these simple tips to ensure your spraying project is a success.

Spray Techniques

Use a piece of scrap cardboard to practice spraying techniques before spraying the work piece.

- For Standard and ProContractor models, use TurboControl to adjust pressure.
- For ProComp models using the remote cup, use TurboControl and pressure regulator on remote cup to adjust pressure.
- Always spray with the least amount of pressure required to provide the desired spray pattern and rate of application. Spraying at pressures higher than necessary wastes material and can result in an orange peel finish.
- To adjust spray gun pattern, see HVLP Edge II gun manual provided with sprayer.

- Aim gun straight at surface. Tilting gun to direct spray angle causes an uneven finish

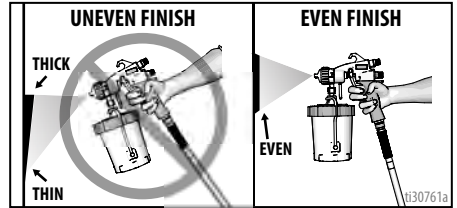

- Flex wrist to keep gun pointed straight. Fanning gun to direct spray at angle causes uneven finish.

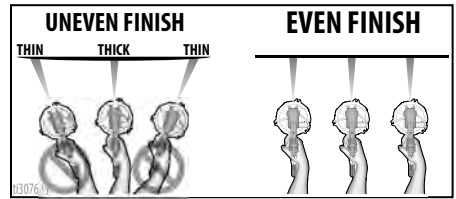

Triggering Gun

Pull trigger after starting stroke. Release trigger before end of strike. Gun must be moving when trigger is pulled and released.

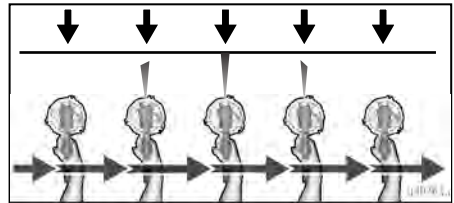

NOTE: To prevent uneven spray pattern, start and end stroke off of work piece surface.

How to Spray

Aiming Gun

Aim center of spray gun at bottom edge of previous stroke, overlapping each stroke by half.

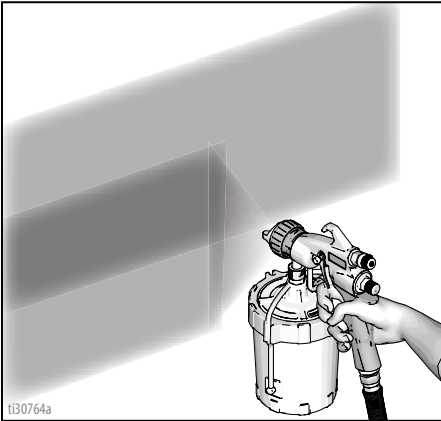

If sprayer does not spray, reference **Troubleshooting**, page 27.

Refilling FlexLiner

1. Perform **Pressure Relief Procedure**, page 10.
2. Reference **Fill FlexLiner System**, page 13.

Refilling Remote Cup

1. Perform **Pressure Relief Procedure**, page 10
2. Reference **Fill Remote Cup (ProComp Models only)**, page 14.

Cleanup

Cleaning your sprayer and gun after every job is important. Proper care and maintenance results in optimal sprayer performance.

Cleaning Filters



Cleaning the filters with flammable solvents may cause the equipment to ignite or explode. Do not use flammable solvents, such as lacquer thinner, to clean the filters.

The sprayer air filters must be clean at all times to provide sufficient air flow to cool the motor and atomize the fluid.

NOTICE

Damage to sprayer can occur if air filters are not cleaned properly.

NOTE: ProContractor and ProComp models have a TurboControl LED indicator. Indicator will blink repeatedly to indicate clogged filter.

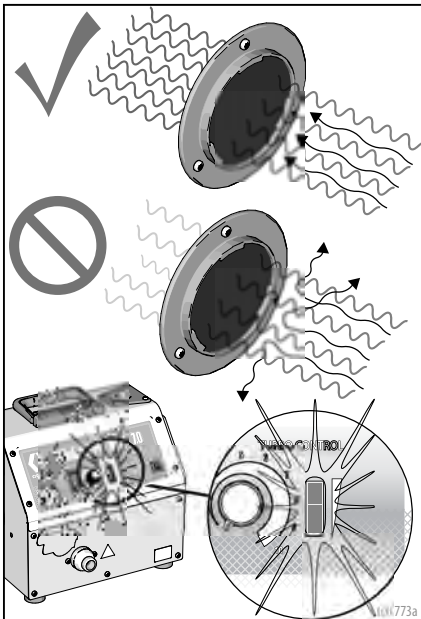

1. Perform **Pressure Relief Procedure**, page 10.
2. Unplug power cord from power outlet.

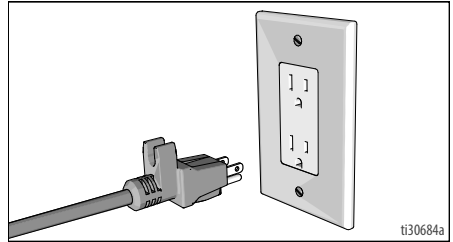

3. Remove turbine and motor air filters.

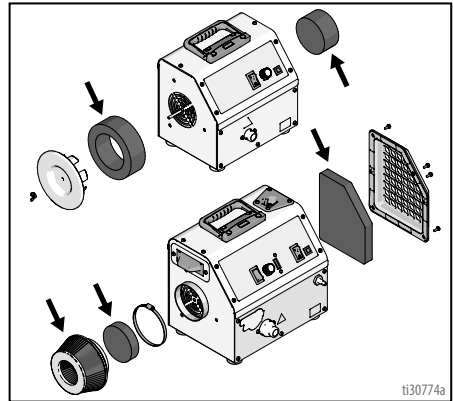

4. Clean air filters and replace as necessary:
 - Tap filter gently on flat surface, dirty side down.
 - Direct compressed air 30 psi (2 bar, 0.2 MPa) through filter from the clean side to the dirty side.

NOTICE

Damage to filter can occur if more than 100 psi (7 bar, 0.7 MPa) is applied.

- Soak filter for 15 minutes in water and mild detergent. Rinse filter until clean. Air dry.