

# Pressure Washers

3A6588D

EN

***For high pressure water cleaning. For professional use only.***

See page 3 for model information and maximum working pressure.



## Important Safety Instructions

Read all warnings and instructions in this manual and in gas engine manual before using the equipment. Save these instructions.

**Direct-Drive Models**

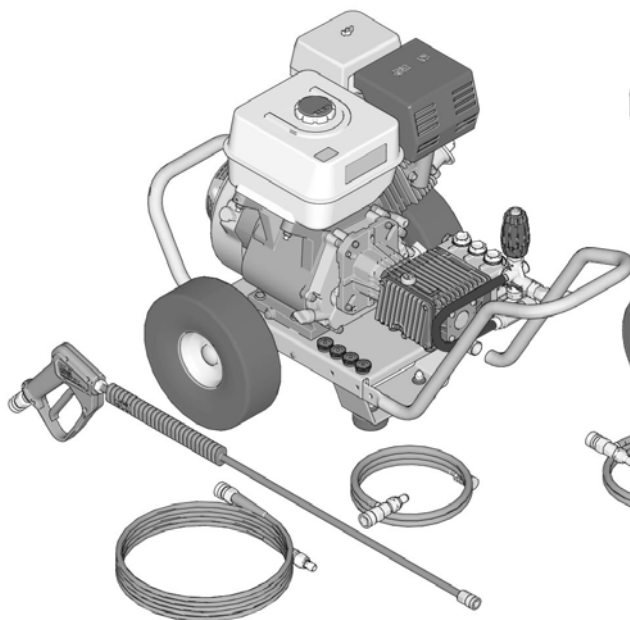

**Belt-Drive Models**

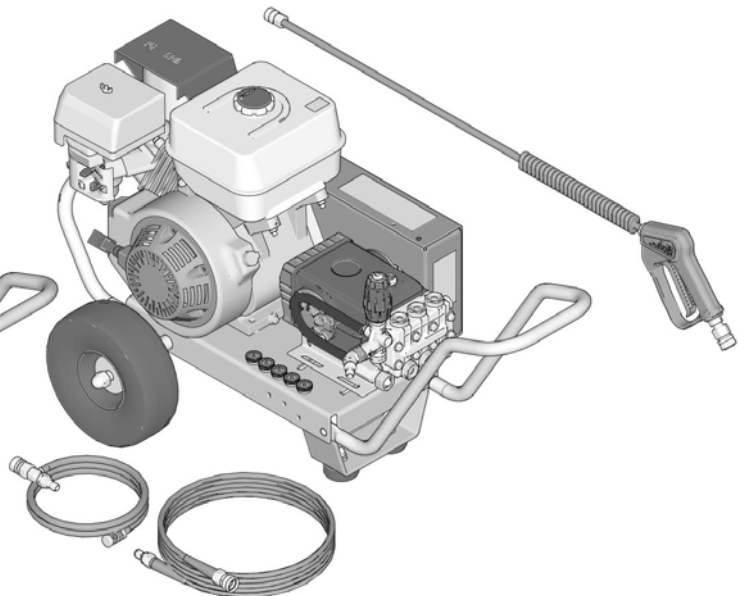

1135057a



# Contents

<b>Models</b> .....	<b>3</b>	<b>Troubleshooting</b> .....	<b>18</b>
<b>Safety Symbol Table</b> .....	<b>4</b>	<b>Parts - Direct-Drive</b> .....	<b>20</b>
<b>Warnings</b> .....	<b>5</b>	Models 25N634, 25N635, 25N636, 25N637, 25N638, 25N639, 25N640, 25N641, 25N677, 25N678, 25N681, 25N682 .....	20
<b>Component Identification</b> .....	<b>8</b>	<b>Parts List - Direct-Drive</b> .....	<b>21</b>
Direct-Drive Models .....	8	Models 25N634, 25N635, 25N636, 25N637, 25N638, 25N639, 25N640, 25N641, 25N677, 25N678, 25N681, 25N682 .....	21
<b>Component Identification</b> .....	<b>9</b>	<b>Parts List - Pump 17Z102, 17Z103, 17Z104</b> .....	<b>22</b>
Belt-Drive Models .....	9	Models 25N634, 25N635, 25N636, 25N637, 25N638, 25N639, 25N640, 25N641 .....	22
<b>Pressure Relief Procedure</b> .....	<b>10</b>	Parts List .....	22
<b>Before Starting the Machine</b> .....	<b>11</b>	<b>Parts - Pump 127385</b> .....	<b>23</b>
Personal Protective Equipment .....	11	Models 25N677, 25N681 .....	23
Equipment Placement .....	11	<b>Parts - Pump 127383</b> .....	<b>24</b>
Water Pump Oil .....	11	Models 25N678, 25N682 .....	24
Engine Fuel Tank .....	11	Parts List .....	24
<b>Setup</b> .....	<b>12</b>	<b>Parts - Belt-Drive</b> .....	<b>25</b>
Connect Water Supply .....	12	Models 25N679, 25N683, 25N680, 25N684 .....	25
Connect the hoses .....	12	<b>Parts List - Belt-Drive</b> .....	<b>26</b>
Priming the Pump .....	12	Models 25N679, 25N683, 25N680, 25N684 .....	26
Nozzle Selection .....	13	<b>Parts - Pump 127384</b> .....	<b>27</b>
Nozzle Connection .....	13	Models 25N679, 25N683 .....	27
Starting the Washer .....	14	Parts List .....	27
Unloader .....	14	<b>Parts - Pump 127382</b> .....	<b>28</b>
Cleaning with Detergents .....	15	Models 25N680, 25N684 .....	28
Shutdown .....	15	Parts List .....	28
<b>Storage</b> .....	<b>16</b>	<b>Technical Specifications</b> .....	<b>29</b>
Winterizing .....	16	CALIFORNIA PROPOSITION 65 .....	32
<b>Maintenance</b> .....	<b>17</b>	<b>Graco Standard Warranty</b> .....	<b>33</b>
Engine .....	17	<b>Graco Information</b> .....	<b>33</b>
Pump .....	17		
Nozzles .....	17		
Quick Couplers .....	17		
Belt Tension Adjustment .....	17		





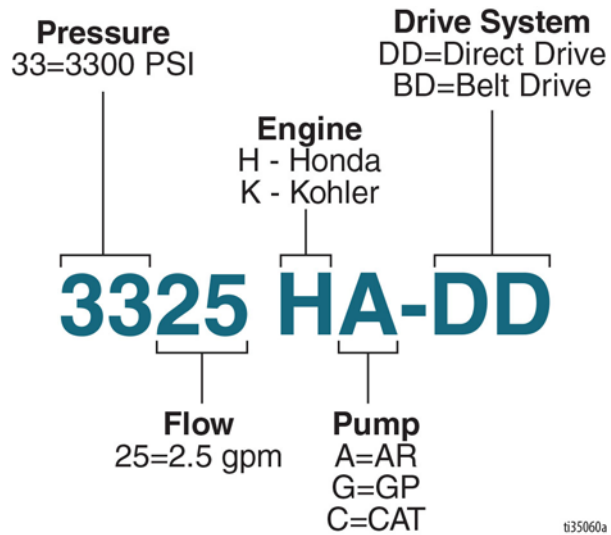





# Models

Part No.	Model	Operating Pressure			Flow	Engine	Pump	Drive System
		PSI	MPa	Bar	GPM			
25N634	3325 HA-DD	3300	22.7	227	2.5	Honda	AR	Direct Drive
25N638								
25N635	3230 HA-DD	3200	22.1	221	3.0	Honda	AR	Direct Drive
25N639								
25N636	4240 KA-DD	4200	29	290	4.0	Kohler	AR	Direct Drive
25N640								
25N637	4240 HA-DD	4200	29	290	4.0	Honda	AR	Direct Drive
25N641								
25N677	4040 HG-DD	4000	27.6	276	4.0	Honda	GP	Direct Drive
25N681								
25N678	4040 HC-DD	4000	27.6	276	4.0	Honda	CAT	Direct Drive
25N682								
25N679	4040 HG-BD	4000	27.6	276	4.0	Honda	GP	Belt Drive
25N683								
25N680	4040 HC-BD	4000	27.6	276	4.0	Honda	CAT	Belt Drive
25N684								



# Safety Symbol Table









The following safety symbols appear throughout this manual and on warning labels. Read the table below to understand what each symbol means.

Symbol	Meaning
	Burn Hazard
	Moving Parts Pinch
	Electric Shock Hazard
	Fall Hazard
	Fire and Explosion Hazard
	Entanglement Hazard
	Recoil Hazard
	Skin Injection Hazard
	Splash Hazard
	Fire Hazard

Symbol	Meaning
	Do Not Overfill Gas Tank
	Toxic Fluid or Carbon Monoxide Hazard
	Do Not Stop Leaks or Deflect Leaks
	Do Not Spray People or Animals
	Eliminate Ignition Sources
	Hold Firmly With Both Hands
	Perform Pressure Relief Procedure
	Read Manual Before Using Equipment
	Wear Personal Protective Equipment
	Equipment Misuse Hazard

# Warnings



The following warnings are for the setup, use, maintenance, and repair of this equipment. The exclamation point symbol alerts you to a general warning and the hazard symbols refer to procedure-specific risks. When these symbols appear in the body of this manual or on warning labels, refer back to these Warnings. Product-specific hazard symbols and warnings not covered in this section may appear throughout the body of this manual where applicable.

 <h1 style="margin: 0;">WARNING</h1>	
	<p><b>CARBON MONOXIDE HAZARD</b></p> <p>Exhaust contains poisonous carbon monoxide, which is colorless and odorless. Breathing carbon monoxide can cause death.</p> <ul style="list-style-type: none"> <li>Do not operate internal combustion engine in an enclosed area.</li> <li>Ensure that any exhaust emissions are not in the vicinity of any air intakes.</li> </ul>
 	<p><b>RECOIL HAZARD</b></p> <p>Gun may recoil when triggered. If you are not standing securely, you could fall and be seriously injured.</p> <ul style="list-style-type: none"> <li>Hold onto gun/wand firmly with both hands to avoid kickbacks.</li> </ul>
	<p><b>FALL HAZARD</b></p> <p>Use of this equipment can create puddles and slippery surfaces. High pressure spray could cause you to fall if you are too close to the cleaning surface.</p> <ul style="list-style-type: none"> <li>Keep spray nozzle between 8 to 24 inches (20 to 60 cm) away from cleaning surface.</li> <li>Always operate equipment on a stable surface.</li> <li>Cleaning area should have adequate slopes and drainage to reduce possibility of falls due to slippery surfaces.</li> <li>Be extremely careful if you must operate equipment from ladder, scaffolding, or any other relatively unstable location.</li> </ul>
   	<p><b>FIRE AND EXPLOSION HAZARD</b></p> <p>Flammable vapors in the <b>work area</b> and can ignite or explode. To help prevent fire and explosion:</p> <ul style="list-style-type: none"> <li>Do not spray flammable liquids.</li> <li>Operate pressure washers outdoors only.</li> <li>Eliminate all ignition sources; such as pilot lights, cigarettes, portable electric lamps, and plastic drop cloths (potential static arc).</li> <li>When transporting or repairing equipment, transport or repair with the fuel tank empty or with fuel shutoff valve turned off.</li> <li>Do not fill fuel tank while engine is running or hot; shut off engine and let it cool. Leave 5/8 inch (16 mm) at top of tank for fuel expansion. Fuel is flammable and can ignite or explode if spilled on hot surface.</li> <li>Keep work area free of debris, including solvent, rags and gasoline.</li> </ul>

 <h1 style="margin: 0;">WARNING</h1>	
	<p><b>ELECTRIC SHOCK HAZARD</b> Spray contact with electrical wiring can result in serious injury or death.</p> <ul style="list-style-type: none"> <li>• Keep water spray away from electric wiring.</li> </ul>
   	<p><b>SKIN INJECTION HAZARD</b> High-pressure spray is able to inject toxins into the body and cause serious bodily injury. In the event that injection occurs, <b>get immediate surgical treatment.</b></p> <ul style="list-style-type: none"> <li>• Keep clear of nozzle. Do not spray any person, yourself or any animal.</li> <li>• Keep hands and other body parts away from the discharge. Do not try to stop leaks with any part of the body.</li> <li>• This product is to be used only by trained operators.</li> <li>• Use caution when cleaning and changing nozzle tips. In the case where the nozzle tip clogs while spraying, follow the <b>Pressure Relief Procedure</b> for turning off the unit and relieving the pressure before removing the nozzle tip to clean.</li> <li>• Do not leave the unit energized or under pressure while unattended. When the unit is not in use, turn off the unit and follow the <b>Pressure Relief Procedure</b> for turning off the unit.</li> <li>• Check hoses and parts for signs of damage. Replace any damaged hoses or parts.</li> <li>• Use Graco replacement parts or accessories that are approved for the rated pressure of the pressure washer.</li> <li>• Always engage the trigger lock when not spraying. Verify the trigger lock is functioning properly.</li> <li>• Verify that all connections are secure before operating the unit.</li> <li>• Know how to stop the unit and bleed pressure quickly. Be thoroughly familiar with the controls.</li> </ul>
	<p><b>BURN HAZARD</b> Running engines produce heat and hot exhaust gases. Temperature of muffler and nearby areas can reach or exceed 150° F (65° C). Fire or severe burns can occur.</p> <ul style="list-style-type: none"> <li>• Do not touch hot surfaces.</li> <li>• Stay clear of exhaust gases.</li> <li>• Never move equipment while operating.</li> <li>• Allow equipment to cool before touching.</li> </ul>
	<p><b>ENTANGLEMENT HAZARD</b> Rotating parts can cause serious injury.</p> <ul style="list-style-type: none"> <li>• Keep clear of moving parts.</li> <li>• Do not operate equipment with protective guards or covers removed.</li> </ul>
 	<p><b>TOXIC FLUID OR FUMES HAZARD</b> Toxic fluids or fumes can cause serious injury or death if splashed in the eyes or on skin, inhaled, or swallowed.</p> <ul style="list-style-type: none"> <li>• Do not use pressure washer to dispense hazardous detergents or acid-type cleaners.</li> <li>• Do not alter chemical injector feature that is listed in the manual.</li> <li>• Read Safety Data Sheets (SDSs) to know the specific hazards of the fluids you are using.</li> <li>• Route exhaust away from work area.</li> </ul>



# WARNING

 	<p><b>EQUIPMENT MISUSE HAZARD</b></p> <p>Misuse can cause death or serious injury.</p> <ul style="list-style-type: none"> <li>• Always wear appropriate gloves, eye protection, and a respirator or mask when spraying.</li> <li>• Do not operate or spray near children. Keep children away from equipment at all times.</li> <li>• Do not overreach or stand on an unstable support. Keep effective footing and balance at all times.</li> <li>• Stay alert and watch what you are doing.</li> <li>• Do not leave the unit energized or under pressure while unattended. When the unit is not in use, turn off the unit and follow the <b>Pressure Relief Procedure</b> for turning off the unit.</li> <li>• Do not operate the unit when fatigued or under the influence of drugs or alcohol.</li> <li>• Keep operating area clear of all persons.</li> <li>• Do not kink or over-bend the hose.</li> <li>• Do not expose the hose to temperatures or to pressures in excess of those specified by manufacturer.</li> <li>• Do not use the hose as a strength member to pull or lift the equipment.</li> <li>• Follow the maintenance instructions specified in the manual.</li> <li>• Do not alter or modify equipment. Alterations or modifications may void agency approvals and create safety hazards.</li> <li>• Make sure all equipment is rated and approved for the environment in which you are using it.</li> </ul>
	<p><b>PERSONAL PROTECTIVE EQUIPMENT</b></p> <p>Wear appropriate protective equipment when in the work area to help prevent serious injury, including eye injury, hearing loss, inhalation of toxic fumes, and burns. Protective equipment includes but is not limited to:</p> <ul style="list-style-type: none"> <li>• Protective eyewear, and hearing protection.</li> <li>• Respirators, protective clothing, and gloves as recommended by the detergent manufacturer.</li> </ul>
	<p>The following instructions are required by California state law, section 4442 of the California Public Resource Code. Other states may have similar laws. Federal laws apply on federal land.</p> <ul style="list-style-type: none"> <li>• A spark arrestor must be added to the muffler of this engine if it is to be used on any forest-covered, brush-covered, or grass-covered unimproved land.</li> <li>• See your engine or equipment dealer for spark arrestor muffler options.</li> </ul>

# Component Identification

## Direct-Drive Models

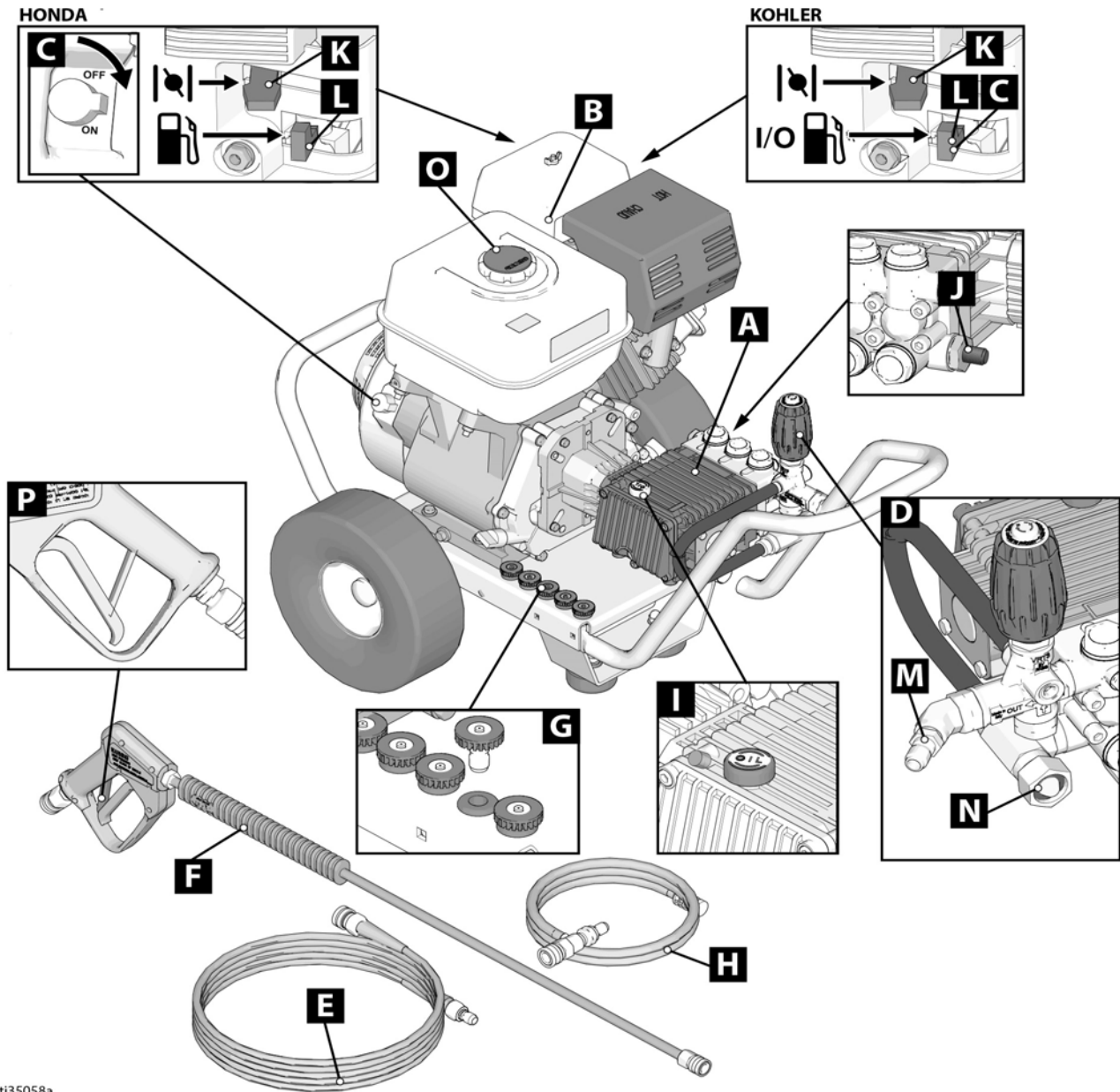

ti35058a

A	Water Pump
B	Engine
C	ON/OFF Switch
D	Unloader
E	High-Pressure Washer Hose
F	Gun
G	Nozzles
H	Chemical Injector Hose

I	Pump Oil Cap
J	Thermal Relief Valve
K	Choke
L	Fuel Valve
M	High-Pressure Outlet
N	Low-Pressure Inlet
O	Gas Cap
P	Trigger Lock



# Component Identification

## Belt-Drive Models

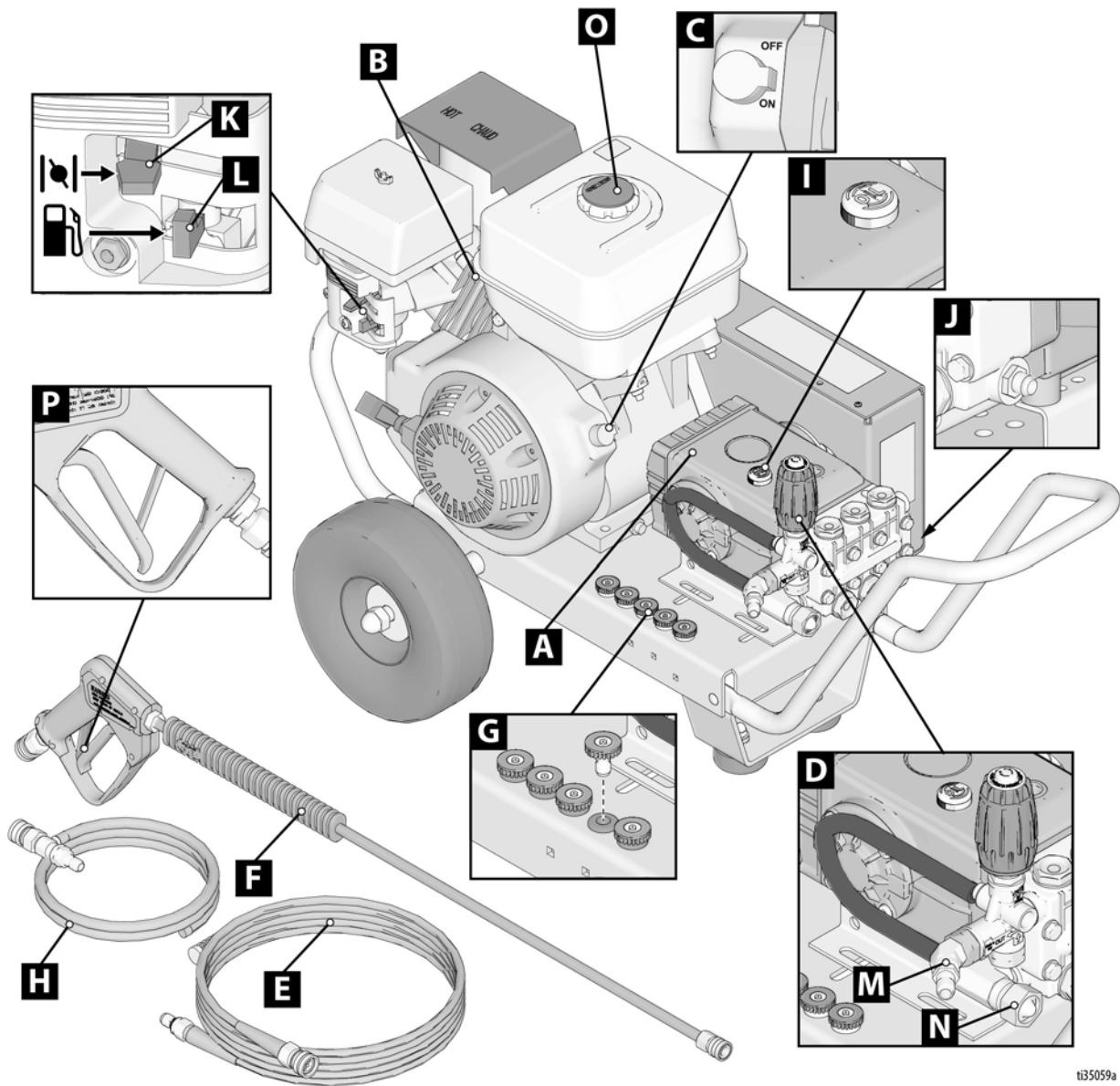

ti35059a

A	Water Pump
B	Engine
C	ON/OFF Switch
D	Unloader
E	High-Pressure Washer Hose
F	Gun
G	Nozzles
H	Chemical Injector Hose

I	Pump Oil Cap
J	Thermal Relief Valve
K	Choke
L	Fuel Valve
M	High-Pressure Outlet
N	Low-Pressure Inlet
O	Gas Cap
P	Trigger Lock

# Pressure Relief Procedure



Follow the Pressure Relief Procedure whenever you see this symbol.

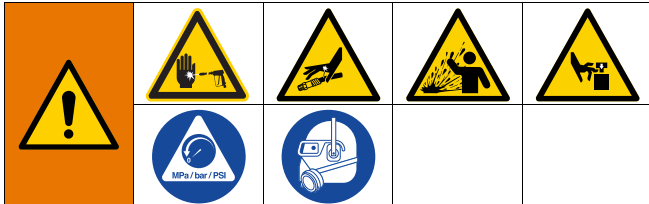

This equipment stays pressurized until pressure is manually relieved. To help prevent serious injury from pressurized fluid, such as skin injection, splashing fluid and moving parts, follow the Pressure Relief Procedure when you stop spraying and before cleaning, checking, or servicing the equipment.

1. Engage trigger lock.
2. Turn unit off.
3. Shut off water supply. Disconnect from water.
4. Disengage trigger lock.
5. Trigger gun to relieve pressure.
6. Engage trigger lock.
7. If you suspect the nozzle or hose is clogged or that pressure has not been fully relieved:
  - a. **VERY SLOWLY** disconnect the hose from the washer to relieve pressure.
  - b. Disconnect hose, gun, and nozzle completely.
  - c. Clear the obstruction in the hose or nozzle.

## Thermal Relief Valve

To ensure the water temperature does not exceed acceptable levels, never allow the unit to operate continuously in bypass mode (unit running with gun trigger closed) for more than three minutes.

All units have a thermal relief valve to protect the pump. It may begin to open and release water if the water temperature in the pump has exceeded 140°F (60°C). This will allow fresh, cool water to enter the system.

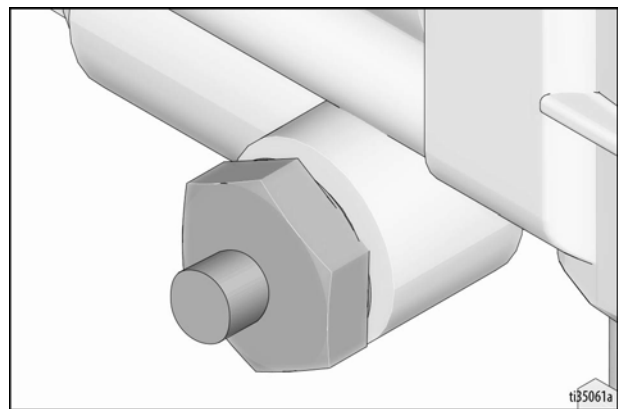

# Before Starting the Machine

## Personal Protective Equipment



### INJECTION AND INHALATION HAZARD

Proper attire is essential to your safety. It is advised to utilize whatever means necessary to protect eyes, ears and skin. Additional safety attire (such as respiratory mask) may be required when using detergent cleaning agents with this unit.

## Equipment Placement

This unit should only be placed on a level surface while operating to ensure proper lubrication for the engine and water pump.

Be certain to block wheels to prevent unit from moving while operating.

## Water Pump Oil

Using the oil dipstick, check the oil level to assure the oil is at the appropriate level.

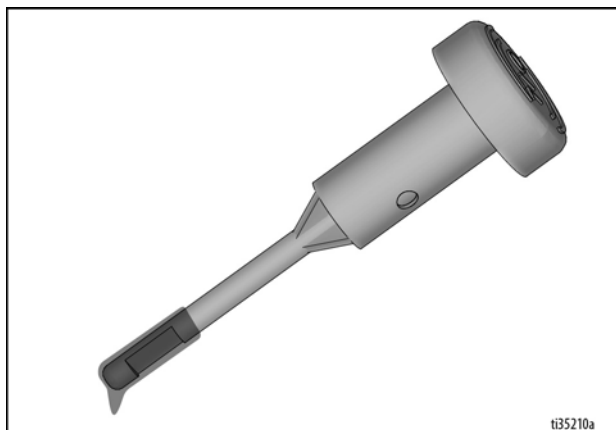

Some units have an oil sight glass on the water pump. Make sure the oil is at the maximum level before each use. If the level appears to be low, add Pump Oil and fill only to the max level on the dipstick. Do not overfill.

## Engine Fuel Tank



A minimum of 86 octane fuel is recommended for use with this unit. Do not mix oil with gasoline.

Purchase fuel in quantities that may be used within 30 days. Use of clean, fresh lead-free gasoline is recommended. Leaded gasoline may be used if lead-free is unavailable.



### EXPLOSIVE FUEL CAN CAUSE FIRES AND SEVERE BURNS

Stop engine before filling fuel tank. Leave 5/8 inch (16mm) at top of tank for fuel expansion.

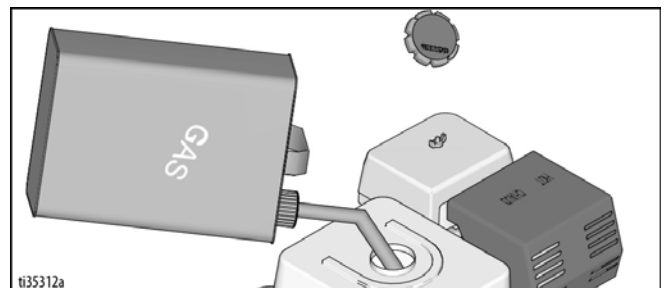

Occasional carburetor and choke adjustments will be necessary for the engine. Refer to the engine manual supplied with this unit for proper adjustment procedures.

Review the engine manual accompanying this pressure washer for correct engine start-up and maintenance procedures.

# Setup

## Connect Water Supply

Select a water supply hose which is a quality grade of garden hose measuring at least 3/4 in. (19.05 mm) in ID and no longer than 50 feet (15.24 m).

Check the water inlet strainer to make sure it is clean and free of any obstructions. Periodic cleaning of the water strainer will help prevent pump problems.

### NOTICE

As a strainer becomes obstructed, it restricts proper flow of water to the pump. This can result in cavitation which will cause premature failure of pump packings.

## Connect the hoses

1. Connect one end of water supply hose to water inlet of unit.
2. Connect other end of hose to pressurized water supply. When connecting water inlet to water supply, local regulations of your water company must be observed. In some areas, the unit must not be connected directly to public drinking water supply. This prevents feedback of the detergents into the water supply. Direct connection is permitted if a back flow preventer is installed.
3. Connect high pressure washer hose to water outlet of unit.
4. Connect other end of pressure washer hose to gun assembly.

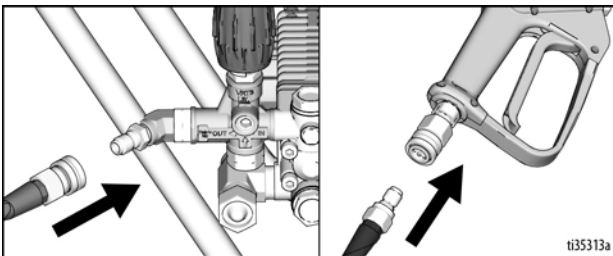

Follow incoming water requirements listed below:

1. Water pressure must be a minimum of 25 psi (0.17 MPa, 1.72 bar) and a maximum of 125 psi (0.86 MPa, 8.6 bar). **NOTE:** A typical outdoor faucet will generally supply this psi if fully turned on.

2. Incoming GPM must be at least one gallon more than the outgoing GPM stated on pressure washer nameplate. **NOTE:** You can check GPM by timing how long it takes to fill a 5 gallon container.
3. Incoming water temperature must not exceed 140° F (60° C).

### NOTICE

Excessive pump damage may result if the water temperature exceeds acceptable levels.

Never allow the unit to operate without the incoming water line attached and the water supply fully turned on. Damage to the equipment could occur.

## Priming the Pump

It is essential to prime the pump on initial start-up and each time the water supply is disconnected from the unit after initial use.

1. Lay high pressure hose out straight to eliminate the possibility for kinks to restrict flow.

**NOTE:** The nozzle assembly should not be connected to the gun assembly at this time.

2. Engage trigger lock and point gun away from yourself or anyone else. Make sure water supply is fully turned on.
3. Disengage trigger lock and squeeze trigger.

**NOTE:** Low pressure water will begin flowing from hose/gun assembly. This allows unit to prime and purge any air from system. Unit is primed when water flow is uninterrupted by air.

4. Once unit is primed, release trigger and engage trigger lock. Securely connect nozzle assembly. See **Nozzle Connection**, page 13.

### NOTICE

Make sure the nozzle is not connected to the unit while priming the pump. Priming allows mineral deposits to be released from the system which could obstruct or damage the nozzle assembly resulting in costly repairs.

## Nozzle Selection

Various nozzles may be quick-connected into the end of the wand to change the spray pattern or use the detergent feature.

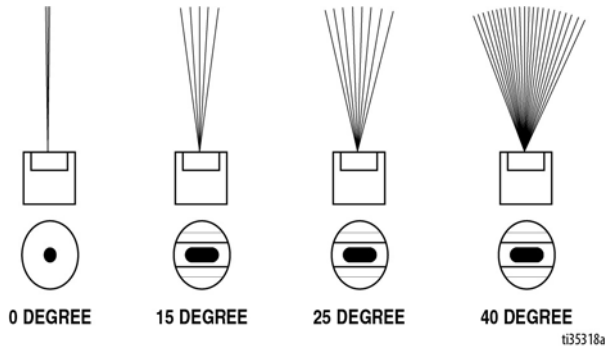

### 0° - BLASTING

- Removing caked on mud from heavy construction, farm or lawn equipment.
- Cleaning tar, glue or stubborn stains from concrete.
- Cleaning overhead areas.
- Removing rust from steel and oxidation from aluminum.

### 15° - STRIPPING

- Removing paint from wood, masonry or metal.
- Removing grease or dirt from equipment.
- Removing heavy mildew stains.
- Removing marine growth from boats and marine equipment.
- Removing rust from steel and oxidation from aluminum.

### 25° - CLEANING

- General cleaning of dirt, mud and grime.
- Cleaning roofs, gutters and downspouts.
- Removing light mildew stains.
- Removing algae and bacteria build-up from pools.
- Rinsing surfaces in preparation for painting.

### 40° - WASHING

- Light cleaning and washing.
- Washing and rinsing of automobiles and boats.
- Cleaning roofs, windows, patios and driveways.

### 65° - CHEMICAL/DETERGENT

- Applying chemicals/detergents at low pressure to help clean the surface.
- Tough stains that require the aid of a chemical agent to remove.

## Nozzle Connection

<p><b>EJECTED PARTS HAZARD</b></p> <p>When using quick connects, be certain the connection is securely locked. If connections are not securely locked, the high pressure water may eject the nozzle from the wand, causing severe injury or serious damage. Always point wand away from you when changing nozzle.</p>				

1. Perform **Pressure Relief Procedure**, page 10.
2. Engage trigger lock.
3. Connect nozzle by retracting the locking ring on the quick-connect fitting and inserting the nozzle.

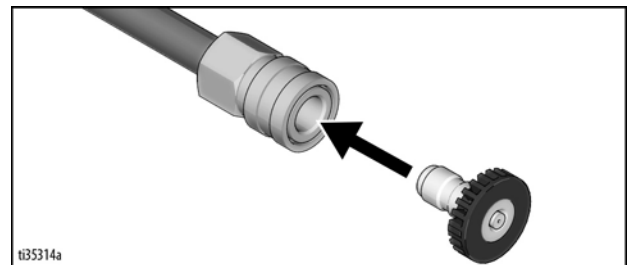

4. Verify the locking ring returns to its operating position after inserting the nozzle.

## Starting the Washer



Never look directly into the nozzle. High pressure water creates a risk for severe injury.

1. Engage trigger lock and point gun away from yourself or anyone else. Make sure water supply is fully turned on.
2. Verify pump is primed. See **Priming the Pump**, page 12.
3. Turn the engine switch to the ON position, as well as the fuel valve (if supplied with) and adjust choke as needed. Then start engine by pulling recoil rope.

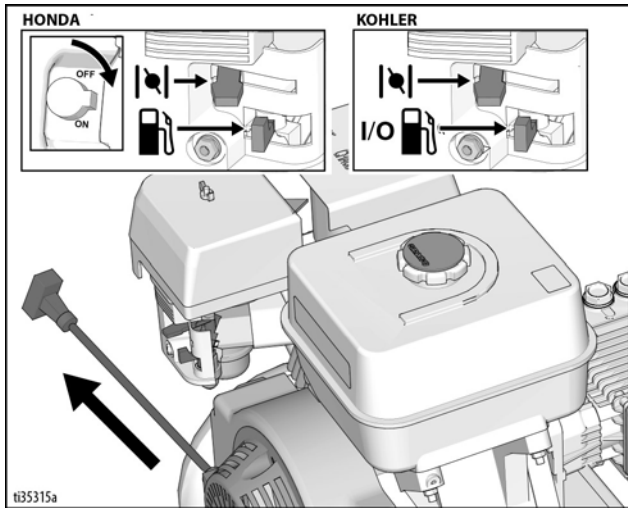

Brace yourself. Hold onto gun/wand firmly with both hands. Gun will kick back from high pressure created by pump once engine has started.

4. Disengage trigger lock and trigger gun several times. Verify high pressure water is sprayed.
5. Make sure to engaged trigger lock whenever changing nozzles and/or when not in use.

### NOTICE

Do not allow unit to operate in bypass mode (with trigger closed) for more than three minutes without triggering gun. This can cause premature failure of pump packing seals and result in costly pump repair.

This pressure washer delivers a high pressure spray and a variety of spray patterns. There are many cleaning jobs that can be done without the use of detergents. If a cleaning agent is required, see **Cleaning with Detergents**, page 15, for correct procedures.

### NOTICE

Do not allow spray pattern to remain on a fixed area for an extended period of time. Possible damage to that area may occur.

## Unloader

### Adjustment Knob

The unloader valve on your machine is equipped with an adjustment knob to adjust the pressure. If less pressure is needed, turn the adjustment knob counter-clockwise. To set back to maximum, turn adjustment knob fully clockwise. Do not over tighten.

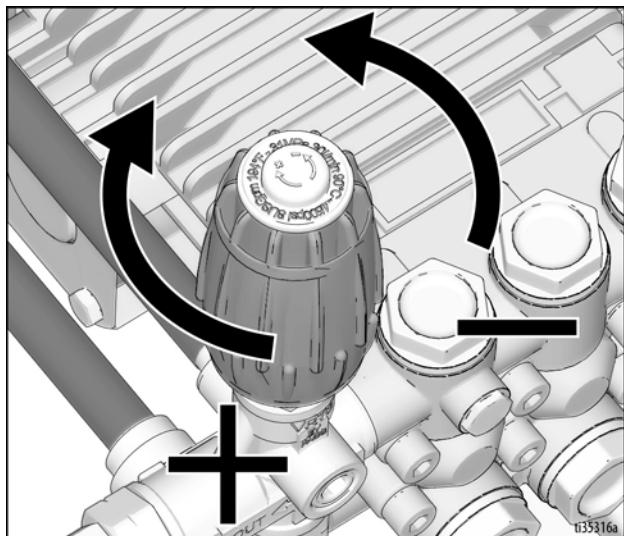

### NOTICE

Do not overtighten the unloader. Breakage could result in immediate loss of water pressure and costly repairs.

## Cleaning with Detergents

				
<p><b>BURN OR EXPLOSION HAZARD</b> Always wear protective safety attire.</p> <p>Prepare detergent solution according to label directions. Never pump hazardous detergents or acid-type cleaners through unit.</p>				

All units are equipped with a chemical injection kit. Locate the clear vinyl hose that is shipped with your unit.

**NOTE:** This injection system is designed to apply detergents under low pressure only. It will not allow detergent solutions to be introduced into the system unless the chemical/detergent nozzle is used.

1. Perform **Pressure Relief Procedure**, page 10.
2. Install chemical injector hose between the pump outlet and the high-pressure washer hose inlet. For washers shipped with an integrated chemical injector, attach the clear chemical injection tube to the barb on the injector.

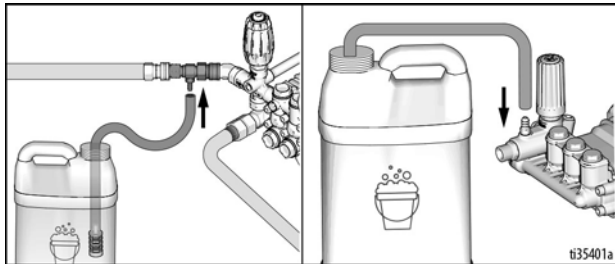

3. Adjust pressure to the lowest point by turning the pressure knob counterclockwise on the unloader valve.
4. Immerse detergent strainer into detergent solution to allow detergent to siphon.
5. Engage trigger lock and secure the chemical/detergent nozzle (65° BLACK) into end of wand. See **Nozzle Connection**, page 13.

6. Start the washer. See **Starting the Washer**, page 14.
7. To apply solution; disengage trigger lock and squeeze trigger. A detergent/water mixture will exit low pressure nozzle. Start spraying lower portion of surface being cleaned and move up, using long overlapping strokes. **NOTE:** Applying from the bottom up helps to avoid streaking. Allow to soak briefly. Do not allow detergent solution to dry on the surface. Avoid working on hot surfaces or in direct sunlight to minimize the chances of the detergent drying, which may result in damaging painted surfaces. Rinse a small section at a time.
8. To rinse; engage trigger lock and securely connect desired high pressure nozzle into end of wand. Disengage trigger lock and spray. It will take about 30 seconds to purge all detergent from line. For best rinsing results, start at the top and work down. See **Nozzle Connection**, page 13.
9. Siphon a gallon of water through low pressure detergent injection system after each use. This reduces the possibility of corrosion or detergent residue causing mechanical problems during next use.

## Shutdown



1. Perform **Pressure Relief Procedure**, page 10.
2. Once pressure is relieved, disconnect nozzle assembly.
3. Disconnect and drain gun, wand and hose.
4. Wipe unit clean and store with gun, wand and hoses in a non-freezing area. See **Storage**, page 16.

# Storage

1. Shut off unit and water supply.
2. Relieve system pressure by pointing gun away from yourself and anyone else and squeezing trigger until water flow ceases to exit nozzle.
3. Disconnect and drain hose, gun and wand.
4. Start unit and allow it to run until all water exits from unit. Once water has stopped flowing from unit, turn unit off.
5. Store hose, gun and wand with unit in a non-freezing area.

## NOTICE

If unit was stored in this manner, but exposed to freezing temperatures, caution should be used as ice chips can form from drops of water which could lead to equipment damage. Allow unit to completely thaw before starting.

## Winterizing



For storage and transportation purposes in subfreezing ambient temperatures, it will be necessary to winterize the unit. The unit must be protected to the lowest incurred temperature to prevent permanent damage.

## NOTICE

The pumping system in this unit may be permanently damaged if any part of the system becomes frozen. Freeze damage is not covered by warranty.

If you must store the unit in an area where the temperature falls below 32° F (0° C), perform the following steps:

## NOTICE

Do not operate unit in a freezing environment. Damage to washer could occur.

Gather the following items:

- Two 5 gallon (18.9 liter) containers.
- One gallon (3.8 liter) of antifreeze.
- Water supply.
- Three foot (0.92 m) hose, 1/2-3/4 in. (13-19 mm) ID with a 3/4 in. male garden hose fitting.

## Procedure

1. To start winterizing, unit must be primed (see **Priming the Pump**, page 12.).
2. After priming, perform **Pressure Relief Procedure**, page 10.
3. Engage trigger lock and remove nozzle.
4. In one 5 gallon (18.9 liter) container, mix antifreeze and water according to manufacturer's recommendations for winterizing temperature.
 

**NOTE:** Proper winterizing is based on the recommended manufacturer's instructions listed on the Protections Chart shown on the back label of most antifreeze containers.
5. Remove water supply hose from unit and attach 3 ft hose securely to inlet connection. Submerge other end into antifreeze solution.
6. Point wand into empty container and start unit.
7. Trigger gun until antifreeze begins to exit wand. Release trigger for 3 seconds, then trigger gun for 3 seconds. Continue cycling gun several times until all antifreeze mixture is siphoned from container.
8. Shut engine off.
9. Detach 3 ft hose from unit and drain any excess antifreeze back into 5 gallon (18.9 liter) container.
10. Disconnect hose/gun/wand assembly from unit and drain any excess antifreeze back into 5 gallon (18.9 liter) container.
11. Store antifreeze solution for next use or dispose of according to local regulations.



# Maintenance

## Engine

The engine instructions that accompany the unit detail specific procedures for engine maintenance. Following the engine manufacturer's recommendations will extend engine life.

## Pump

The pump oil must be changed after the first 25 hours of operation on all units. Once the initial oil change has been completed, it is recommended the oil be changed every 3 months or 250 hour intervals. If oil appears dirty or milky, changes may be required at a greater frequency. Add pump oil and fill only to the center of the sight glass or max level on dipstick. Refer to the parts listing for the correct pump oil. Do not overfill.

## Nozzles

Water flow through the spray nozzle will erode the orifice, making it larger and result in a pressure loss. Nozzles should be replaced whenever pressure is less than 85% of the maximum. The frequency of replacement will depend upon such variables as mineral content in the water and number of hours the nozzle is used.

## Quick Couplers

There is an o-ring seal inside the female quick couplers. This o-ring will deteriorate or, if the unit is allowed to pump without the high pressure hose or nozzle attached, the o-ring may be blown out occasionally. Insert a replacement o-ring to correct the leak. Additional o-rings can be purchased from your dealer.

## Belt Tension Adjustment

To maintain peak performance, it may be necessary to occasionally adjust the belt tension. Perform the following steps:

1. Remove belt guard and loosen two nuts on each side of pump.
2. Turn cap screws clockwise or counterclockwise until belt tension is adjusted properly per the tension specifications listed below.

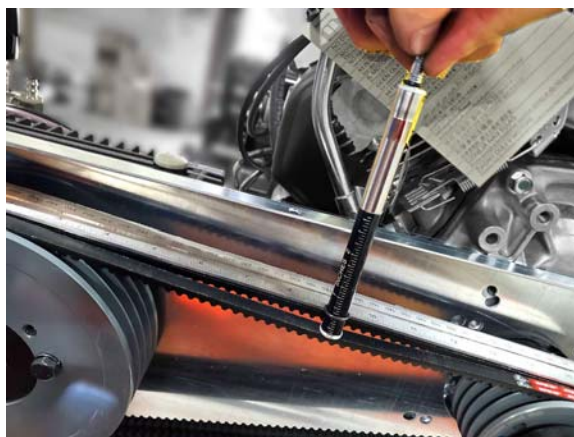

Tension	New Belt	Used Belt
Static Belt Pull (total pull):	337 - 361 lbf	289 - 313 lbf
Belt Deflection Distance:	0.15 in	0.15 in
Belt Deflection Force:	3.8 - 4.1 lbf	3.3 - 3.6 lbf
Sonic Tension Meter:	254 - 272 N	217 - 235 N
Belt Frequency:	141 - 146 Hz	130 - 135 Hz

3. Turn cap screw clockwise until a 1/2 in. (12.7 mm) belt deflection is noticed between the pulleys.
4. Tighten side nuts.
5. Put a straight edge across both pulleys. If necessary, loosen one set of pulley screws and adjust in or out to properly align. Tighten pulley screws and check tension again.
6. Replace belt guard and tighten fasteners securely.

# Troubleshooting



1. Follow **Pressure Relief Procedure**, page 10, before checking or repairing gun.
2. Check all possible problems and causes before disassembling gun.

Problem	Cause	Solution
Engine not starting or hard to start	No gasoline in fuel tank or carburetor	Fill the tank with gasoline and open fuel shut off valve. Check fuel line to carburetor.
	Low oil	Add oil to proper level.
	Start/Stop switch in STOP position	Move switch to START position.
	Water in fuel, or old fuel	Drain fuel tank and carburetor. Use new fuel, and make sure spark plug is dry.
	Engine flooded or improperly choked	Open choke, and crank engine several times to clear out gas. Make sure spark plug is dry.
	Dirty air cleaner filter	Remove and clean.
	Dirty spark plug, wrong gap, or wrong type	Clean spark plug, adjust the gap, or replace.
	Gun not triggered	Trigger gun while starting engine.
Engine not operating properly or lacking power	Partially plugged air cleaner filter	Remove and clean.
	Spark plug dirty, wrong gap, or wrong type	Clean spark plug, adjust the gap, or replace.
Pressure too low and/or pump running roughly	Worn or wrong size nozzle	Replace with nozzle of proper size
	Inlet filter clogged	Clean filter. Check more frequently.
	Worn packings, abrasives in water, or natural wear	Check filter. Replace packings.
	Inadequate water supply	Check water flow rate to pump.
	Belts slipping	Tighten or replace belts; use correct belts, and replace both at same time.
	Fouled or dirty inlet or discharge valves	Clean inlet and discharge valve assemblies. Check filter.
	Restricted inlet	Check if garden hose is collapsed or kinked.
	Worn inlet or discharge valves	Replace worn valves.
	Leak in high-pressure hose	Replace high-pressure hose.
Water leaking from under pump manifold	Worn packings	Install new packings.

<b>Problem</b>	<b>Cause</b>	<b>Solution</b>
Water in pump oil	Humid air condensing inside crankcase	Change oil as specified in <b>Maintenance</b> on page 17.
	Worn packings	Install new packings.
	Oil seals are leaking	Install new oil seals.
Packings failing frequently or prematurely	Scored, damaged, or worn plungers	Install new plungers.
	Abrasive material in the fluid being pumped	Install proper filtration on pump inlet plumbing.
	Inlet water temperature too high	Check water temperature. It should not exceed 140°F (60°C).
	Over pressurized pump	Do not modify any factory-set adjustments. See <b>Equipment Misuse Hazard</b> on page 7.
	Excessive pressure due to partially plugged or damaged nozzle	Clean or replace nozzle. See <b>Nozzle Connection</b> on page 13.
	Pump running too long without spraying	Never run pump more than 3 minutes without spraying.
	Running pump dry	Do not run pump without water.
Strong surging at inlet, and low pressure on discharge side	Foreign particles in the inlet or discharge valve, or worn inlet and/or discharge valves	Clean or replace valves.
No detergent is being siphoned into system	Incorrect nozzle installed	Install chemical/detergent nozzle
	Pressure too high	Adjust pressure to lowest point
	Worn chemical injector valve	Install new chemical injector valve



# Parts List - Direct-Drive

## Models 25N634, 25N635, 25N636, 25N637, 25N638, 25N639, 25N640, 25N641, 25N677, 25N678, 25N681, 25N682

Ref. Part	Description	Qty.	Ref. Part	Description	Qty.	
1	ENGINE		16Y721	Models 25N638, 25N639, 25N641, 25N681, 25N682	1	
116298	GX200 (Models 25N684, 25N638)	1	17Z429	Model 25N636	1	
803900	GX270 (Models 25N635, 25N639)	1	17Z430	Model 25N640	1	
114703	GX390 (Models 25N637, 25N641, 25N677, 25N678, 25N681, 25N682)	1	13▲	LABEL, safety, frame		
18A008	CH440 (Models 25N636, 25N640)	1	16X819	Models 25N634, 25N636, 25N637, 25N677, 25N678, 25N635	1	
2	PUMP		16Y739	Models 25N638, 25N639, 25N640, 25N641, 25N681, 25N682	1	
17Z102	AR/RSV series (Models 25N634, 25N638)	1	14	BRACKET, foot		
17Z103	AR/RSV series (Models 25N635, 25N639)	1	127537	Models 25N634, 25N638, 25N635, 25N639, 25N636, 25N640, 25N637, 25N641	1	
17Z104	AR RSV series (Models 25N636, 25N637, 25N640, 25N641)	1	127538	Models 25N677, 25N678, 25N681, 25N682	1	
127385	GP - EZ series (Models 25N677, 25N681)	1	15	127541	PAD, foot	2
127383	CAT - or 66PPX series (Models 25N678, 25N682)	1	21	127558	GAUGE, quick disconnect (Models 25N638, 25N639, 25N640, 25N641, 25N681, 25N682)	1
3	FRAME, base plate		22	805634	NOZZLE, chemical, black (all models)	1
127471	Models 25N634, 25N638, 25N635, 25N639, 25N636, 25N640, 25N637, 25N641	1	805591	NOZZLE, 0°, red, 2.7 (Models 25N634, 25N638)	1	
127468	Models 25N677, 25N678, 25N681, 25N682	1	805592	NOZZLE, 15°, yellow, 2.7 (Models 25N634, 25N638)	1	
4	18A006	HANDLE, long	1	805593	NOZZLE, 25°, green, 2.7 (Models 25N634, 25N638)	1
5	17Z101	HANDLE, short	1	805539	NOZZLE, 0°, red, 3.5 (Models 25N635, 25N639)	1
6	WHEEL/TIRE		805540	NOZZLE, 15°, yellow, 3.5 (Models 25N635, 25N639)	1	
16Y888	10 in. (Models 25N634, 25N638, 25N635, 25N639, 25N636, 25N640, 25N637, 25N641)	2	805541	NOZZLE, 25°, green, 3.5 (Models 25N635, 25N639)	1	
16Y889	11 in. (Models 25N677, 25N678, 25N681, 25N682)	2	805595	NOZZLE, 0°, red, 3.7 (Models 25N636, 25N637, 25N640, 25N641)	1	
7	244784	GUN	1	805596	NOZZLE, 15°, yellow, 3.7 (Models 25N636, 25N637, 25N640, 25N641)	1
7a	17P089	KIT, O-Ring, 10 Pack	1	805597	NOZZLE, 25°, green, 3.7 (Models 25N636, 25N637, 25N640, 25N641)	1
7b	17P090	KIT, O-Ring, 10 Pack	1	805543	NOZZLE, 0°, red, 4.0 (Models 25N677, 25N678, 25N681, 25N682)	1
8	244783	HOSE	1	805544	NOZZLE, 15°, yellow, 4.0 (Models 25N677, 25N678, 25N681, 25N682)	1
9	127526	UNLOADER (Models 25N677, 25N678, 25N681, 25N682)	1	805545	NOZZLE, 25°, green, 4.0 (Models 25N677, 25N678, 25N681, 25N682)	1
9a	17A642	UNLOADER, complete (Models 25N678, 25N682, 25N677, 25N681)	1	805546	NOZZLE, 40°, white, 4.0 (Models 25N677, 25N678, 25N681, 25N682)	1
	17Z106	KIT, unloader, repair (Models 25N634, 25N635, 25N636, 25N637, 25N638, 25N639, 25N640, 25N641)	1	23	THERMAL VALVE	1
10	127528	HOSE w/ strainer	1	17A562	THERMAL VALVE, Models 25N634, 25N638, 25N635, 25N639, 25N636, 25N640, 25N637, 25N641	1
10a	127529	INJECTOR, chemical w/ hose and strainer (Models 25N677, 25N678, 25N681, 25N682)	1	17A564	THERMAL VALVE, Models 25N677, 25N678, 25N681, 25N682	1
11	LABEL, product		24	801112	INLET, strainer	1
17Y574	Models 25N634, 25N638	1	29	16D576	LABEL, made in USA	1
17Y575	Models 25N635, 25N639	1	30	17Y766	LABEL, gas cap (all models, but 25N636, 25N640)	1
17Y576	Models 25N636, 25N640	1				
17Y577	Models 25N637, 25N641	1				
17Y759	Models 25N677, 25N681	1				
17Y760	Models 25N678, 25N682	1				
12▲	LABEL, safety, gas tank					
194126	Models 25N634, 25N636, 25N637, 25N677, 25N678, 25N635	1				
16Y720	Models 25N638, 25N639, 25N641, 25N681, 25N682	1				

▲ Replacement safety labels, tags, and cards are available at no cost.

# Parts List - Pump 17Z102, 17Z103, 17Z104

Models 25N634, 25N635, 25N636, 25N637, 25N638, 25N639, 25N640, 25N641

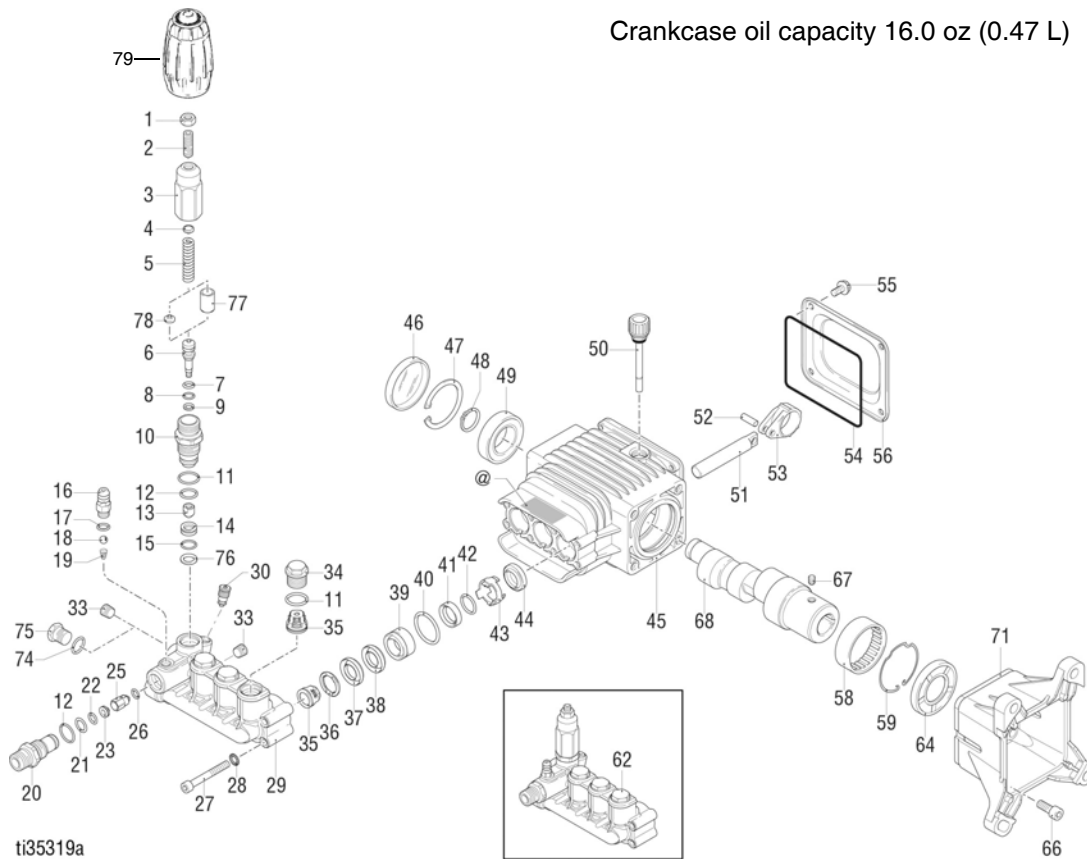

## Parts List

Part	Description	Qty.	Part	Description	Qty.
246377	PUMP, oil, 32 oz	1	★17Z109	KIT, piston (includes 51)	3
17Z106	KIT, unloader (includes 1-15, 79)	1	17Z113	KIT, valve cap (includes 34)	3
★17Z117	KIT, valves (includes 11, 35)	6	★17Z111	KIT, oil seals (includes 44, 46, 54, 64)	3, 1
★17Z112	KIT, water seals (includes 37, 38, 40-42)	3			
127506	KIT, chemical injector (includes 17-19)	1			
17Z110	KIT, oil fill cap (includes 50)	1			
				★ Kit services 3 cylinders	
				† Not all repair parts available through Graco.	

# Parts - Pump 127385

Models 25N677, 25N681

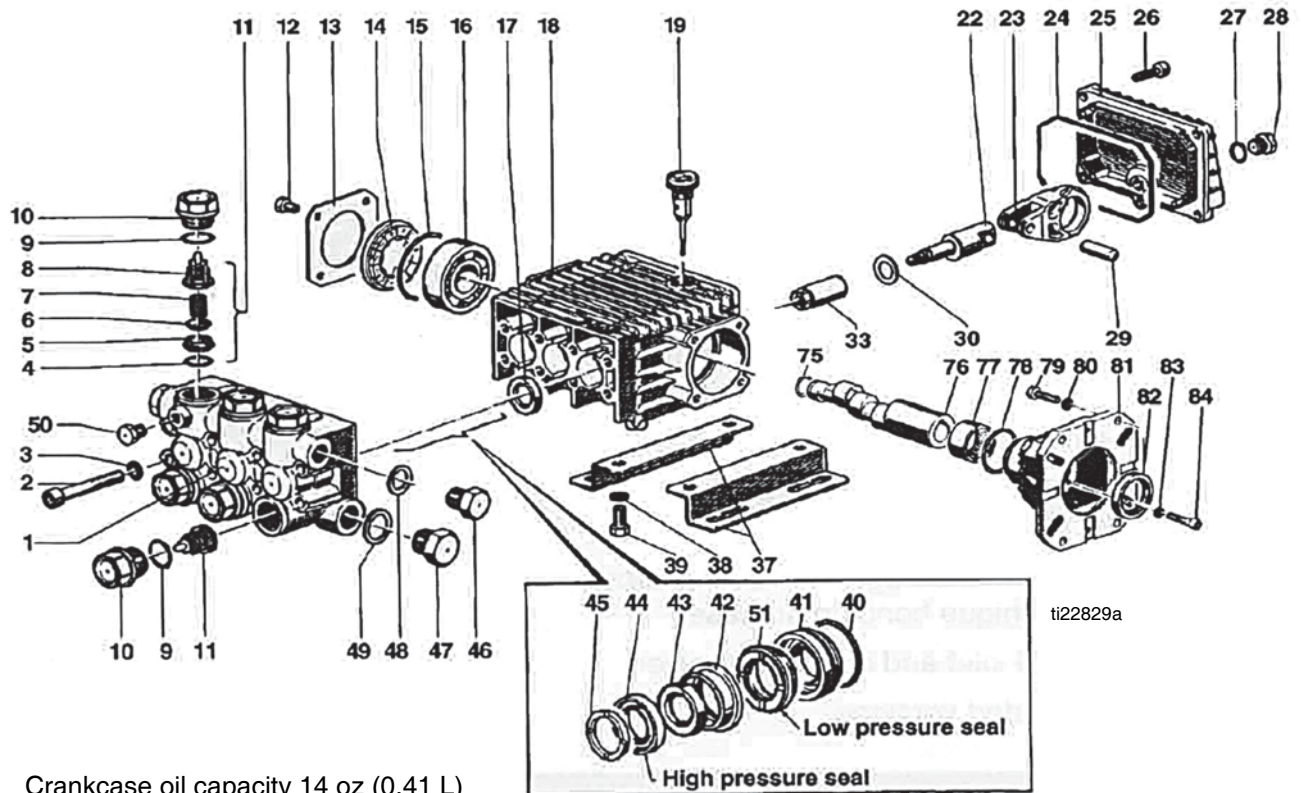

Crankcase oil capacity 14 oz (0.41 L)

## Parts List

Part	Description	Qty.	Part	Description	Qty.
127481★	KIT, repair valve (includes 11)	6	17C738	KIT, oil fill cap, vented w/ o-ring (includes 19)	1
127485★	KIT, valve cap (includes 9, 10)	6	246377	PUMP, oil, 32 oz	1
127486★	KIT, oil seal (includes 17)	3	★ Kit services 3 cylinders		
127487★	KIT, packing (includes 43, 44, 51)	3	❖ Kit services 1 cylinder		
127488❖	KIT, piston (includes 33)	3	† Not all repair parts available through Graco.		





# Parts - Belt-Drive

Models 25N679, 25N683, 25N680, 25N684

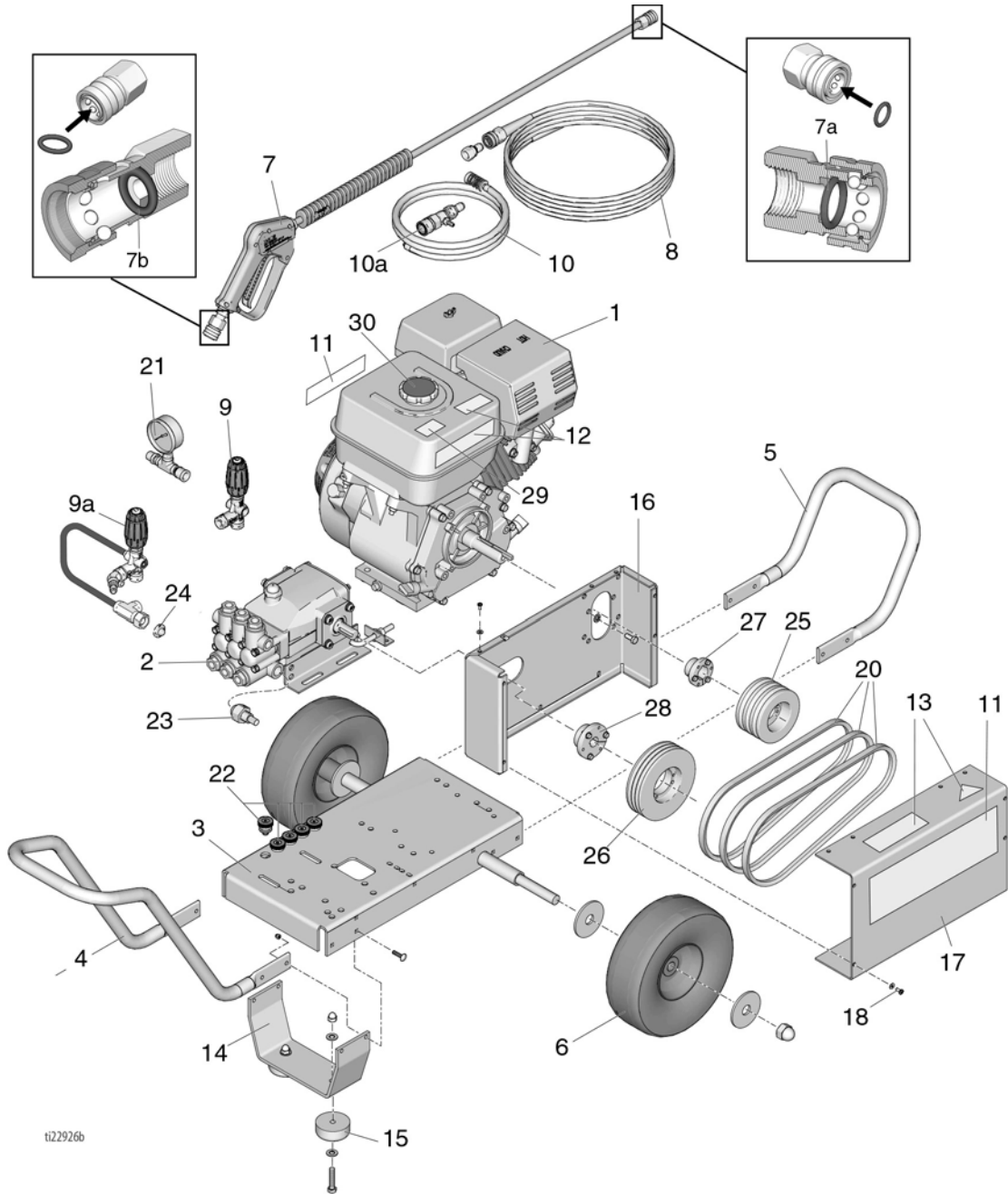

ti22926b

# Parts List - Belt-Drive

## Models 25N679, 25N683, 25N680, 25N684

Ref.	Part	Description	Qty.	Ref.	Part	Description	Qty.
1	114703	ENGINE, GX390	1	16C394	Models 25N683, 25N684, 25N679, 25N680	1	
2		PUMP					
	127384	GP - HP series (Models 25N679, 25N683)	1	14	BRACKET, foot	1	
	127382	CAT - 5PP series (Models 25N680, 25N684)	1	15	127541 PAD, foot	2	
3	18A005	FRAME, base plate	1	16	18A003 BELT GUARD, back	1	
4	18A006	HANDLE, long	1	17	18A004 BELT GUARD, cover	1	
5	127467	HANDLE, short	1	18	127542 FASTENERS, belt guard cover	1	
6	16Y890	WHEEL/TIRE, 12 in.	2	20	127527 KIT, belt	1	
7	244784	GUN	1	21	127558 GAUGE, quick disconnect (Models 25N683, 25N684)	1	
7A	17P089	KIT, O-Ring, 10 Pack	1	22	805543 NOZZLE, 0°, red, 4.0	1	
7B	17P090	KIT, O-Ring, 10 Pack	1		805544 NOZZLE, 15°, yellow, 4.0	1	
8	244783	HOSE	1		805545 NOZZLE, 25°, green, 4.0	1	
9	127526	UNLOADER	1		805546 NOZZLE, 40°, white, 4.0	1	
9a	17A644	UNLOADER, complete	1		805634 NOZZLE, chemical, black	1	
10	127528	HOSE with strainer	1	23	17A564 THERMAL VALVE	1	
10a	127529	INJECTOR, chemical with hose and strainer	1	24	801112 STRAINER, inlet	1	
11		LABEL, product		25	127706 PULLEY, engine, 2.65	1	
	17Y761	Model 25N679, 25N683	1	26	127705 PULLEY, pump, 6"	1	
	17Y762	Model 25N680, 25N684	1	27	127703 BUSHING, engine	1	
12▲		LABEL, safety, gas tank		28	BUSHING, pump		
	194126	Models 25N679, 25N680	1		127704 BUSHING, pump, 24mm, models 25N679, 25N683	1	
	16Y720	Models 25N683, 25N684	1		127707 BUSHING, pump, 20 mm, models 25N680, 25N684	1	
	16Y721	Models 25N683, 25N684	1	29	16D576 LABEL, made in USA	1	
13▲		LABEL, safety, frame		30	17Y766 LABEL, gas cap	1	
	16X819	Models 25N679, 25N680	1				
	16Y739	Models 25N683, 25N684	1				

▲ Replacement safety labels, tags, and cards are available at no cost.

# Parts - Pump 127384

## Models 25N679, 25N683

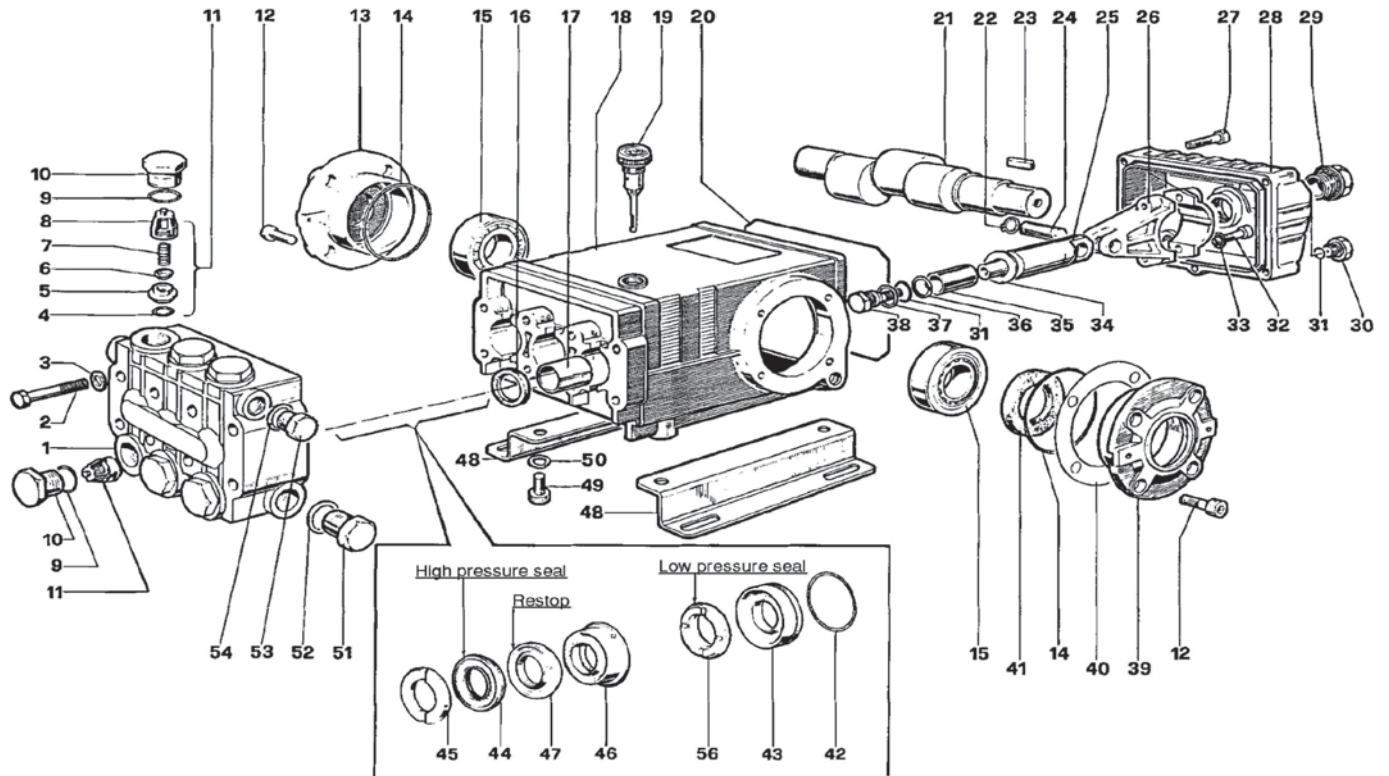

Crankcase oil capacity 40.6 oz (1.2 L)

ti22828a

## Parts List

Part	Description	Qty.	Part	Description	Qty.
127489★	KIT, repair valve (includes 11)	6	246377	PUMP, oil, 32 oz	1
127490★	KIT, valve cap (includes 9, 10)	6	802345	SIGHTGLASS (includes 29)	1
127491★	KIT, oil seal (includes 16)	3	★	Kit services 3 cylinders	
127492★	KIT, packing (includes 44, 47, 56)	3	❖	Kit services 1 cylinder	
127493❖	KIT, piston (includes 35)	1	†	Not all repair parts available through Graco.	
17C740	KIT, oil fill cap, vented w/ o-ring (includes 19)	1			

# Parts - Pump 127382

Models 25N680, 25N684

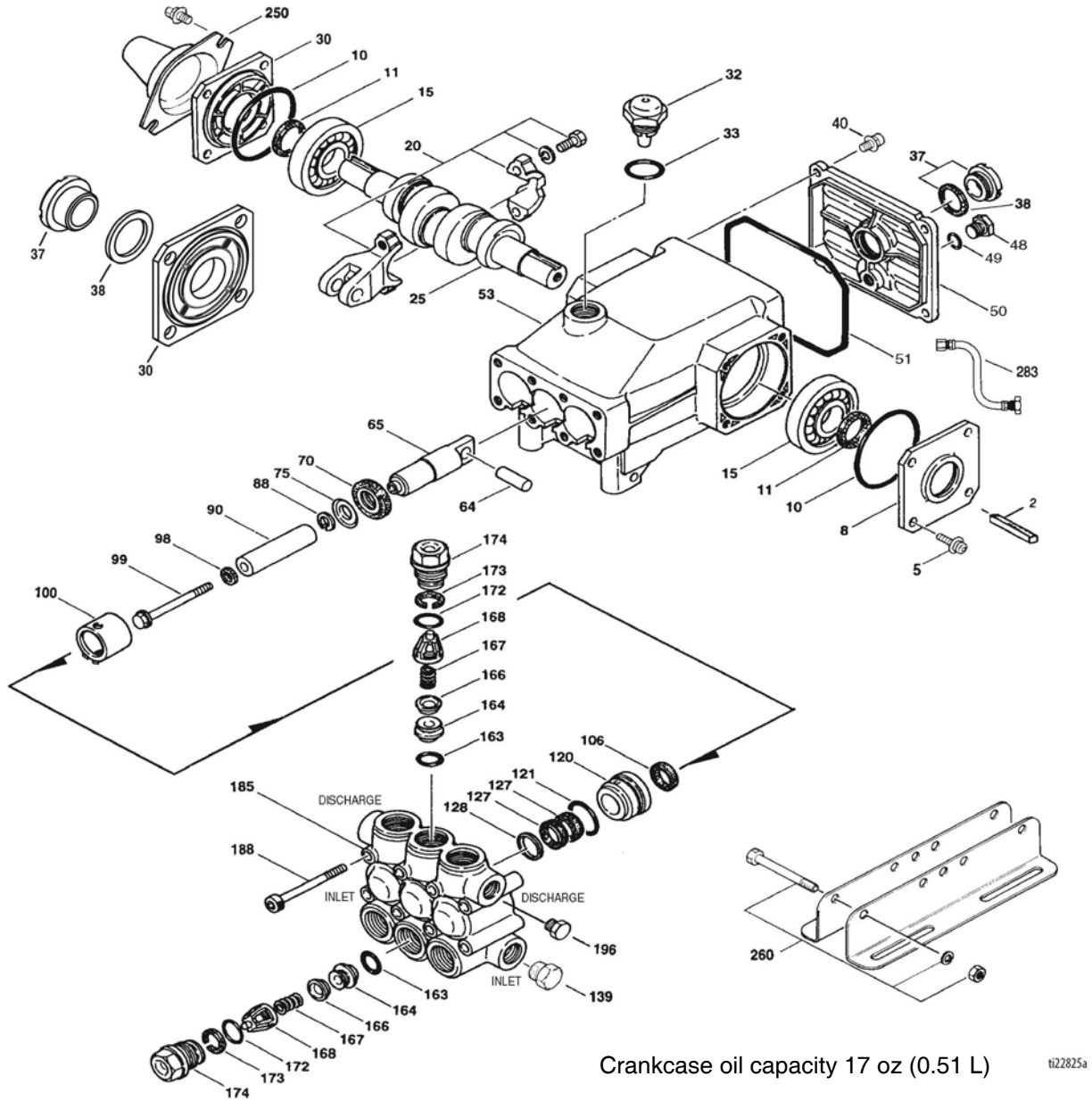

## Parts List

Part	Description	Qty.	Part	Description	Qty.
127498★	KIT, repair valve (includes 163, 164, 166, 167, 168, 172, 173)	6	17Z108	KIT, oil fill cap, vented w/ o-ring (includes 32, 33)	1
127499❖	KIT, oil seal (includes 98, 106, 121, 127, 128)	3	246377	PUMP OIL, 32 oz	1
127500❖	KIT, piston (includes 90)	3	★ Kit services 3 cylinders		
17Z115	KIT, valve, cap (includes 174)	6	❖ Kit services 1 cylinder		
17Z107	SIGHTGLASS (includes 37)	1	† Not all repair parts available through Graco.		

# Technical Specifications

<b>Model 3325 HA-DD (25N634, 25N638)</b>		
	<b>U.S.</b>	<b>Metric</b>
<b>Washer</b>		
Maximum Working Pressure	3300 psi	22.8 MPa, 228bar
Honda Engine Size	GX200	
Gas Tank Capacity	3.8 quarts	3.6 liters
Maximum Delivery	2.5 gpm	9.5 lpm
Drive	Direct	
Hose	3/8 in. x 50 ft (4200 psi)	9.5 mm x 15.2 m (29.0 MPa, 290 bar)
<b>Dimensions</b>		
Length	40.0 in.	101.6 cm
Width	22.5 in.	57.2 cm
Height	24.0 in.	61.0 cm
Weight (bare)	58 lb	26.3 kg
<b>Performance</b>		
Pump Inlet	3/4 ghf	
Pump Outlet	3/8 QC	
Inlet Filter	50 mesh 0.012 in.	50 mesh 0.3 mm
Operating Temperature Range	40° F - 145° F	4° C - 63° C
Sound Pressure measured @ 3.1 ft (1 m)	89.6 dB(A)	
Sound Power per ISO 3744	103.6 dB(A)	

<b>Model 3230 HA-DD (25N635, 25N639)</b>		
	<b>U.S.</b>	<b>Metric</b>
<b>Washer</b>		
Maximum Working Pressure	3200 psi	22 MPa, 220 bar
Honda Engine Size	GX270	
Gas Tank Capacity	6.4 quarts	6.0 liters
Maximum Delivery	3.0 gpm	11.4 lpm
Drive	Direct	
Hose	3/8 in. x 50 ft (4200 psi)	9.5 mm x 15.2 m (29.0 MPa, 290 bar)
<b>Dimensions</b>		
Length	40.0 in.	101.6 cm
Width	22.5 in.	57.2 cm
Height	24.0 in.	61.0 cm
Weight (bare)	77 lb	35.0 kg
<b>Performance</b>		
Pump Inlet	3/4 ghf	
Pump Outlet	3/8 QC	
Inlet Filter	50 mesh 0.012 in.	50 mesh 0.3 mm
Operating Temperature Range	40° F - 145° F	4° C - 63° C
Sound Pressure measured @ 3.1 ft (1 m)	93.1 dB(A)	
Sound Power per ISO 3744	107.2 dB(A)	

<b>Model 4240 KA-DD (25N636, 25N640)</b>		
	<b>U.S.</b>	<b>Metric</b>
<b>Washer</b>		
Maximum Working Pressure	4200 psi	29.0 MPa, 290 bar
Kohler Engine Size	CH440	
Gas Tank Capacity	7.7 quarts	7.3 liters
Maximum Delivery	4.0 gpm	15.1 lpm
Drive	Direct	
Hose	3/8 in. x 50 ft (4200 psi)	9.5mm x 15.2 m (29.0 MPa, 290bar)
<b>Dimensions</b>		
Length	40.0 in.	101.6 cm
Width	22.5 in.	57.2 cm
Height	24.0 in.	61.0 cm
Weight (bare)	105 lb	47.6 kg
<b>Performance</b>		
Pump Inlet	3/4 ghf	
Pump Outlet	3/8 QC	
Inlet Filter	50 mesh 0.012 in.	50 mesh 0.3 mm
Operating Temperature Range	40° F - 145° F	4° C - 63° C
Sound Pressure measured @ 3.1 ft (1 m)	97.0 dB(A)	
Sound Power per ISO 3744	111.1 dB(A)	

<b>Model 4240HA-DD (25N637, 25N641)</b>		
	<b>U.S.</b>	<b>Metric</b>
<b>Washer</b>		
Maximum Working Pressure	4200 psi	29.0 MPa, 290 bar
Honda Engine Size	GX390	
Gas Tank Capacity	6.9 quarts	6.5 liters
Maximum Delivery	4.0 gpm	15.1 lpm
Drive	Direct	
Hose	3/8 in. x 50 ft (4200 psi)	9.5 mm x 15.2 m (29.0 MPa, 290 bar)
<b>Dimensions</b>		
Length	40.0 in.	101.6 cm
Width	22.5 in.	57.2 cm
Height	24.0 in.	61.0 cm
Weight (bare)	102 lb	46.3 kg
<b>Performance</b>		
Pump Inlet	3/4 ghf	
Pump Outlet	3/8 QC	
Inlet Filter	50 mesh 0.012 in.	50 mesh 0.3 mm
Operating Temperature Range	40° F - 145° F	4° C - 63° C
Sound Pressure measured @ 3.1 ft (1 m)	92.2 dB(A)	
Sound Power per ISO 3744	106.4 dB(A)	

<b>Model 4040 HG-DD (25N677, 25N681)</b>		
	<b>U.S.</b>	<b>Metric</b>
<b>Washer</b>		
Maximum Working Pressure	4000 psi	27.6 MPa, 276 bar
Honda Engine Size	GX390	
Gas Tank Capacity	6.9 quarts	6.5 liters
Maximum Delivery	4 gpm	15.1 lpm
Drive	Direct	
Hose	3/8 in. x 50 ft (4200 psi)	9.5 mm x 15.2 m (29.0 MPa, 290 bar)
<b>Dimensions</b>		
Length	41.5 in.	105.4 cm
Width	23.5 in.	59.7 cm
Height	25.0 in.	63.5 cm
Weight (bare)	92 lb	41.7 kg
Pump Inlet	3/4 ghf	
Pump Outlet	3/8 QC	
Inlet Filter	50 mesh 0.012 in.	50 mesh 0.3 mm
Operating Temperature Range	40° F - 145° F	4° C - 63° C
Sound Pressure measured @ 3.1 ft (1 m)	92.2 dB(A)	
Sound Power per ISO 3744	106.4 dB(A)	

<b>Model 4040 HC-DD (25N678, 25N682)</b>		
	<b>U.S.</b>	<b>Metric</b>
<b>Washer</b>		
Maximum Working Pressure	4000 psi	27.6 MPa, 276 bar
Honda Engine Size	GX390	
Gas Tank Capacity	6.9 quarts	6.5 liters
Maximum Delivery	4 gpm	15.1 lpm
Drive	Direct	
Hose	3/8 in. x 50 ft (4200 psi)	9.5 mm x 15.2 m (29.0 MPa, 290 bar)
<b>Dimensions</b>		
Length	41.5 in.	105.4 cm
Width	23.5 in.	59.7 cm
Height	25.0 in.	63.5 cm
Weight (bare)	100 lb	45.4 kg
Pump Inlet	3/4 ghf	
Pump Outlet	3/8 QC	
Inlet Filter	50 mesh 0.012 in.	50 mesh 0.3 mm
Operating Temperature Range	40° F - 145° F	4° C - 63° C
Sound Pressure measured @ 3.1 ft (1 m)	92.2 dB(A)	
Sound Power per ISO 3744	106.4 dB(A)	

<b>Model 4040 HG-BD (25N679, 25N683)</b>		
	<b>U.S.</b>	<b>Metric</b>
<b>Washer</b>		
Maximum Working Pressure	4000 psi	27.6 MPa, 276 bar
Honda Engine Size	GX390	
Gas Tank Capacity	6.9 quarts	6.5 liters
Maximum Delivery	4 gpm	15.1 lpm
Drive	Belt	
Hose	3/8 in. x 50 ft (4200 psi)	9.5 mm x 15.2 m (29.0 MPa, 290 bar)
<b>Dimensions</b>		
Length	42.0 in.	106.7 cm
Width	27.0 in.	68.6 cm
Height	26.0 in.	66 cm
Weight (bare)	132 lb	72.1 kg
Pump Inlet	3/4 ghf	
Pump Outlet	3/8 QC	
Inlet Filter	50 mesh 0.012 in.	50 mesh 0.3 mm
Operating Temperature Range	40° F - 145° F	4° C - 63° C
Sound Pressure measured @ 3.1 ft (1 m)	92.2 dB(A)	
Sound Power per ISO 3744	106.4 dB(A)	

<b>Model 4040 HC-BD (25N680, 25N684)</b>		
	<b>U.S.</b>	<b>Metric</b>
<b>Washer</b>		
Maximum Working Pressure	4000 psi	27.6 MPa, 276 bar
Honda Engine Size	GX390	
Gas Tank Capacity	6.9 quarts	6.5 liters
Maximum Delivery	4 gpm	15.1 lpm
Drive	Belt	
Hose	3/8 in. x 50 ft (4200 psi)	9.5 mm x 15.2 m (29.0 MPa, 290 bar)
<b>Dimensions</b>		
Length	42.0 in.	106.7 cm
Width	27.0 in.	68.6 cm
Height	26.0 in.	66 cm
Weight (bare)	132 lb	60.0 kg
Pump Inlet	3/4 ghf	
Pump Outlet	3/8 QC	
Inlet Filter	50 mesh 0.012 in.	50 mesh 0.3 mm
Operating Temperature Range	40° F - 145° F	4° C - 63° C
Sound Pressure measured @ 3.1 ft (1 m)	92.2 dB(A)	
Sound Power per ISO 3744	106.4 dB(A)	

## CALIFORNIA PROPOSITION 65



**WARNING:** This product can expose you to chemicals known to the State of California to cause cancer and birth defects or other reproductive harm. For more information go to [www.P65Warnings.ca.gov](http://www.P65Warnings.ca.gov).



# Graco Standard Warranty

Graco warrants all equipment referenced in this document which is manufactured by Graco and bearing its name to be free from defects in material and workmanship on the date of sale to the original purchaser for use. With the exception of any special, extended, or limited warranty published by Graco, Graco will, for a period of twelve months from the date of sale, repair or replace any part of the equipment determined by Graco to be defective. This warranty applies only when the equipment is installed, operated and maintained in accordance with Graco's written recommendations.

This warranty does not cover, and Graco shall not be liable for general wear and tear, or any malfunction, damage or wear caused by faulty installation, misapplication, abrasion, corrosion, inadequate or improper maintenance, negligence, accident, tampering, or substitution of non-Graco component parts. Nor shall Graco be liable for malfunction, damage or wear caused by the incompatibility of Graco equipment with structures, accessories, equipment or materials not supplied by Graco, or the improper design, manufacture, installation, operation or maintenance of structures, accessories, equipment or materials not supplied by Graco.

This warranty is conditioned upon the prepaid return of the equipment claimed to be defective to an authorized Graco distributor for verification of the claimed defect. If the claimed defect is verified, Graco will repair or replace free of charge any defective parts. The equipment will be returned to the original purchaser transportation prepaid. If inspection of the equipment does not disclose any defect in material or workmanship, repairs will be made at a reasonable charge, which charges may include the costs of parts, labor, and transportation.

**THIS WARRANTY IS EXCLUSIVE, AND IS IN LIEU OF ANY OTHER WARRANTIES, EXPRESS OR IMPLIED, INCLUDING BUT NOT LIMITED TO WARRANTY OF MERCHANTABILITY OR WARRANTY OF FITNESS FOR A PARTICULAR PURPOSE.**

Graco's sole obligation and buyer's sole remedy for any breach of warranty shall be as set forth above. The buyer agrees that no other remedy (including, but not limited to, incidental or consequential damages for lost profits, lost sales, injury to person or property, or any other incidental or consequential loss) shall be available. Any action for breach of warranty must be brought within two (2) years of the date of sale.

**GRACO MAKES NO WARRANTY, AND DISCLAIMS ALL IMPLIED WARRANTIES OF MERCHANTABILITY AND FITNESS FOR A PARTICULAR PURPOSE, IN CONNECTION WITH ACCESSORIES, EQUIPMENT, MATERIALS OR COMPONENTS SOLD BUT NOT MANUFACTURED BY GRACO.** These items sold, but not manufactured by Graco (such as electric motors, switches, hose, etc.), are subject to the warranty, if any, of their manufacturer. Graco will provide purchaser with reasonable assistance in making any claim for breach of these warranties.

In no event will Graco be liable for indirect, incidental, special or consequential damages resulting from Graco supplying equipment hereunder, or the furnishing, performance, or use of any products or other goods sold hereto, whether due to a breach of contract, breach of warranty, the negligence of Graco, or otherwise.

## **FOR GRACO CANADA CUSTOMERS**

The Parties acknowledge that they have required that the present document, as well as all documents, notices and legal proceedings entered into, given or instituted pursuant hereto or relating directly or indirectly hereto, be drawn up in English. Les parties reconnaissent avoir convenu que la rédaction du présente document sera en Anglais, ainsi que tous documents, avis et procédures judiciaires exécutés, donnés ou intentés, à la suite de ou en rapport, directement ou indirectement, avec les procédures concernées.

# Graco Information

For the latest information about Graco products, visit [www.graco.com](http://www.graco.com).

For patent information, see [www.graco.com/patents](http://www.graco.com/patents).

**TO PLACE AN ORDER**, contact your Graco distributor or call 1-800-690-2894 to identify the nearest distributor.

*All written and visual data contained in this document reflects the latest product information available at the time of publication.  
Graco reserves the right to make changes at any time without notice.*

Original instructions. This manual contains English. MM 3A6588

**Graco Headquarters:** Minneapolis

**International Offices:** Belgium, China, Japan, Korea

**GRACO INC. AND SUBSIDIARIES • P.O. BOX 1441 • MINNEAPOLIS MN 55440-1441 • USA**  
**Copyright 2019, Graco Inc. All Graco manufacturing locations are registered to ISO 9001.**

[www.graco.com](http://www.graco.com)  
Revision D, June 2021