

# SNOOC

LIGHTING CREATOR



## S200F0

A light, a world of possibilities

The housing is cast from 356 aluminum alloy with a minimum thickness of 3/16" (5mm) and is composed of two sections. The front section includes a prismatic lens of polymethylmethacrylate (PMMA), better known as acrylic or acrylic glass, the heat sink, the converter and the LED module.

The back section is used to attach to the wall. The opening is held with two screws on the bottom for a quick and easy access to the LED module and the converter.

# S200F0

## TYPE

1 : I            3 : III  
2 : II           4 : IV

## SOURCE

Light-emitting diodes

Power	Color
<b>30W</b> : 30W	<b>AK</b> : Ambre
<b>50W</b> : 50W	<b>3K</b> : 4000K
<b>75W</b> : 75W	<b>4K</b> : 3000K

## TYPE OF CONVERTER

**1S** : 120 to 277V, standard  
**5S** : 347 to 480V, standard  
**1D** : 120 to 277V, dimmable (0-10 volts DC)  
**5D** : 347 to 480V, dimmable (0-10 volts DC)

## FINISH

<b>AT</b> : Anthracite	<b>DZ</b> : Textured bronze
<b>BK</b> : Black	<b>FG</b> : Forest green
<b>BZ</b> : Brown	<b>PE</b> : Pewter
<b>DB</b> : Textured black	<b>PG</b> : Pine green
<b>DS</b> : Silver	<b>WH</b> : White
<b>DW</b> : Textured white	<b>XX</b> : On request

## ORDER EXAMPLE

S200F03 75W4K 1S BK

(S200F0, type III, 75W LED, 4000K,  
120à 277V, Black)

## WARRANTIES

- Lifetime warranty on cast aluminum components.
- 5-year warranty against paint peeling.
- 10-year warranty on LED lighting system and 5-year warranty on converter.
- Replacement parts available for a minimum of 20 years.

All our optical systems have been tested by an independent laboratory according to IESNA LM-79.

The LEDs used in our LED modules meet the IESNA LM-80 standard.

Our fixtures are certified and comply with applicable CSA and UL standards (suitable for wet environments)

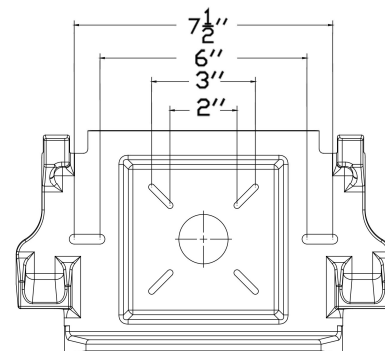
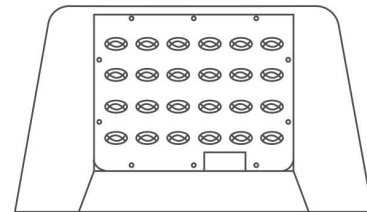
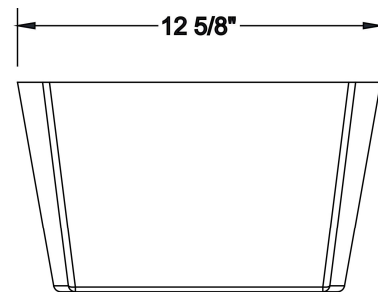
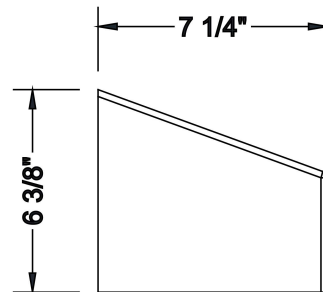

For other options, please refer to your representative