

4

3

2

1

REVISIONS				
ZONE	REV	DESCRIPTION	DATE	APPROVED

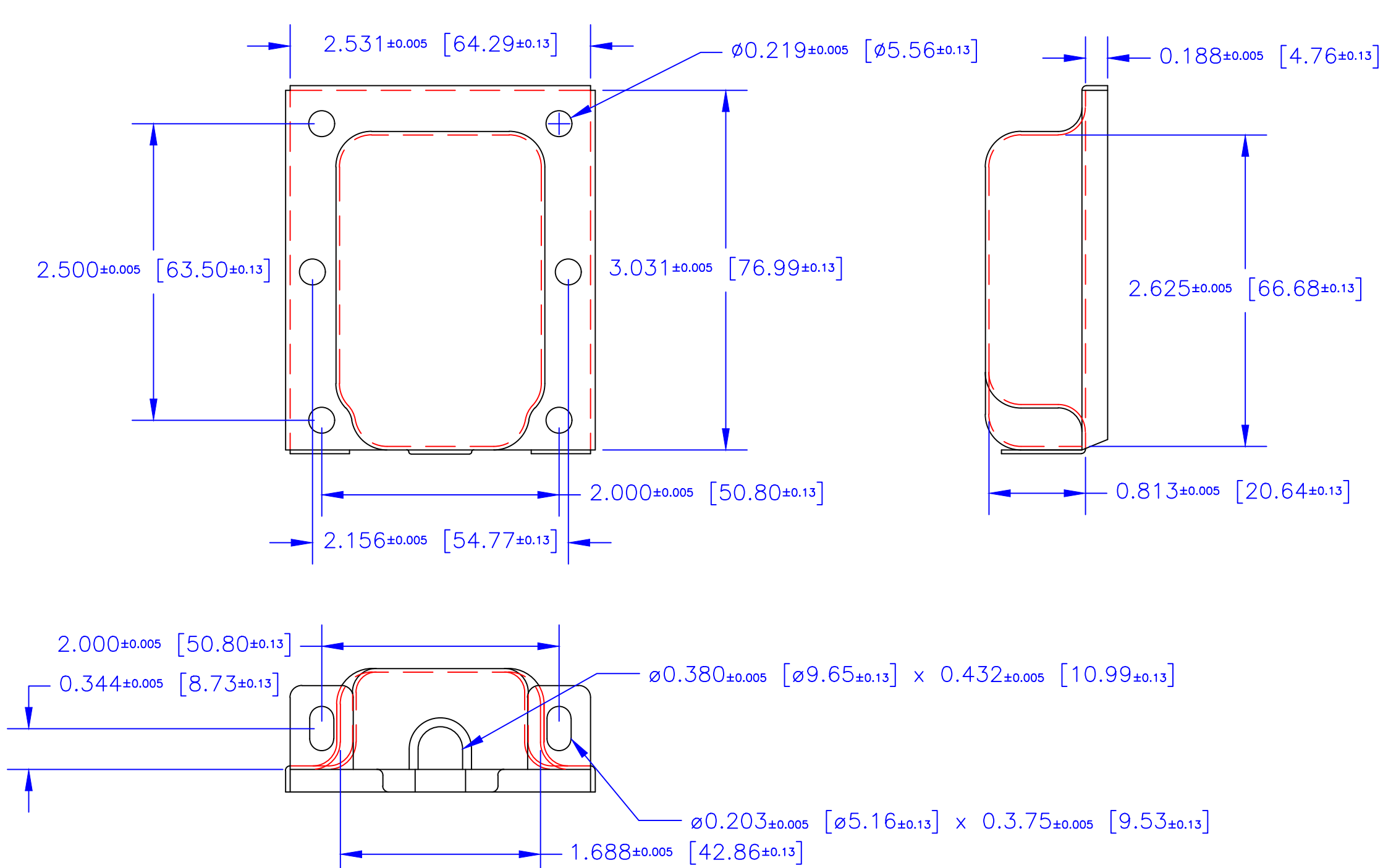

**\*\*NOTES: UNLESS OTHERWISE SPECIFIED!**

1. All material is UL listed.
2. All material are to be RoHS compliant.
3. 22 ga. colled rolled steel.

DIMENSIONS ARE IN INCHES (MILLIMETERS). X.XXX = ±0.010 X.XX = ±0.03 ANGLES = ±0.05 UNLESS OTHERWISE SPECIFIED		<b>EDCOR Electronics</b> 7130 National Parks Highway, Carlsbad, NM 88220 Voice: (575) 887-6790 <a href="http://www.edcorusa.com">www.edcorusa.com</a>		
DRAWING BY <b>Brian Weston</b>		Date <b>3/2011</b>		
CHECKED BY <b>Brian Weston</b>		Date <b>3/2011</b>		
APPROVED BY <b>Larry Weston</b>		Date <b>3/2011</b>		
SIZE <b>C</b>		FSCM NO. <b>20000-EB100-V</b>		DWG NO. <b>20000-EB100-V</b>
SCALE: <b>1:1</b>		©2015 EDCOR Electronics		SHEET: <b>1 of 1</b>

4

3

2

1