

4

3

2

1

REVISIONS				
ZONE	REV	DESCRIPTION	DATE	APPROVED

D

D

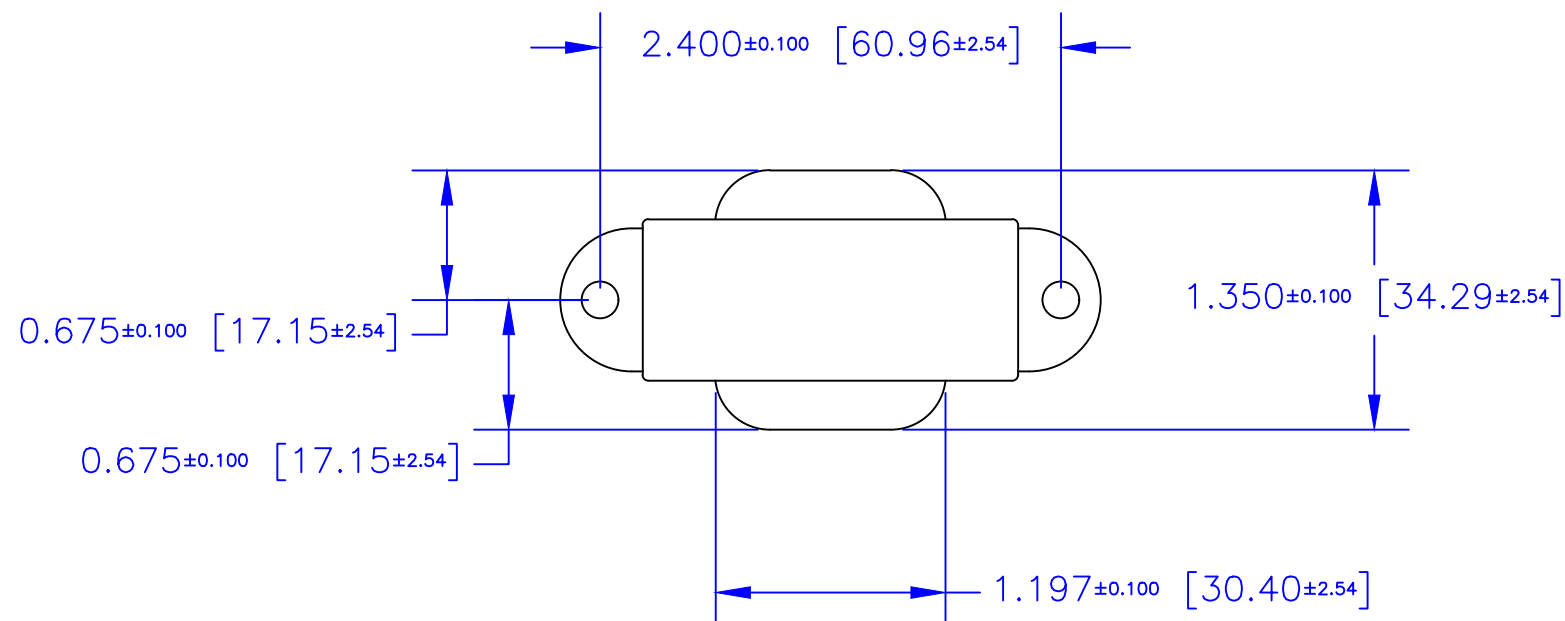

C

C

B

B

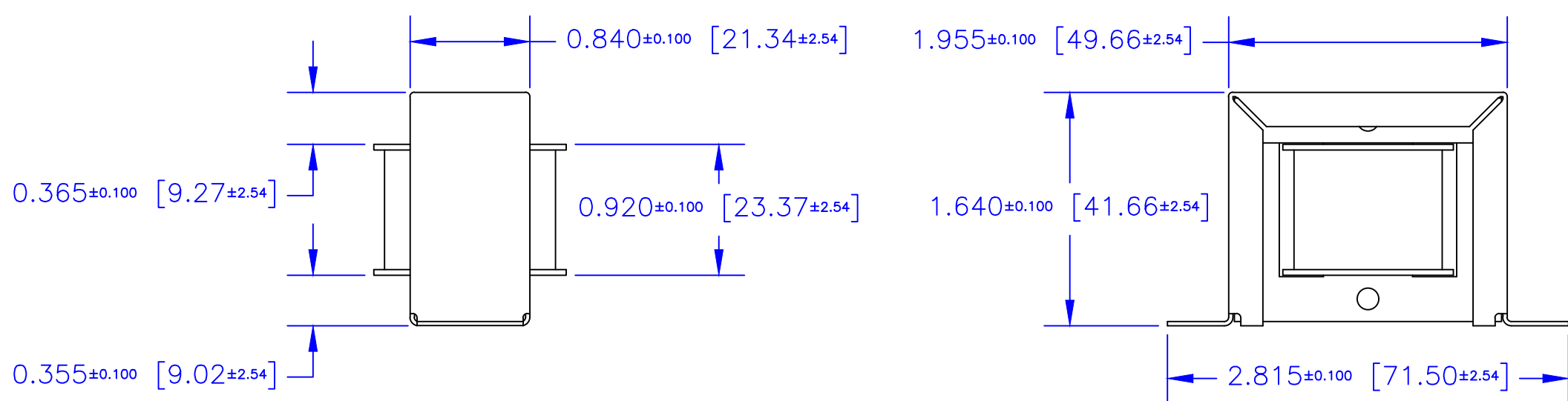

B

B

A

A

- **NOTES: UNLESS OTHERWISE SPECIFIED!**
- All material is UL listed.
 - All material are to be RoHS compliant.
 - Bobbin: Nylon 6/6 30% glass filled, Class B, Flammability 94HB UL E184262.
 - Magnet Wire: Class B, UL E32638, Gauge depending on the transformer design specifications requirement.
 - Finish Tape: Polyester film tape, Class 130°, dielectric strength 5000 volts, UL E17385, guide OANZ2.
 - Core Material: Depending on the transformer design specifications requirement.
 - Termination: Depending on the transformer design specifications requirement.
 - Mounting: Zinc plated steel horizontal channel/frame.
 - Finish: Styrenated alkyd electrical varnish, air cured, UL E63933.

DIMENSIONS ARE IN INCHES [MILLIMETERS]. X.XXX = ±0.010 X.XX = ±0.03 ANGLES = ±0.05 UNLESS OTHERWISE SPECIFIED		EDCOR Electronics 7130 National Parks Highway, Carlsbad, NM 88220 Voice: (575) 887-6790 www.edcorusa.com		
DRAWING BY Brian Weston		Date 9/2010		
CHECKED BY Brian Weston		Date 9/2010		
APPROVED BY Larry Weston		Date 9/2010		
SIZE C	FSCM NO.	DWG NO. 15000-EI625-075-01	REV	
SCALE: 1:1		©2015 EDCOR Electronics	SHEET: 1 of 1	

4

3

2

1