

REVISIONS				
ZONE	REV	DESCRIPTION	DATE	APPROVED

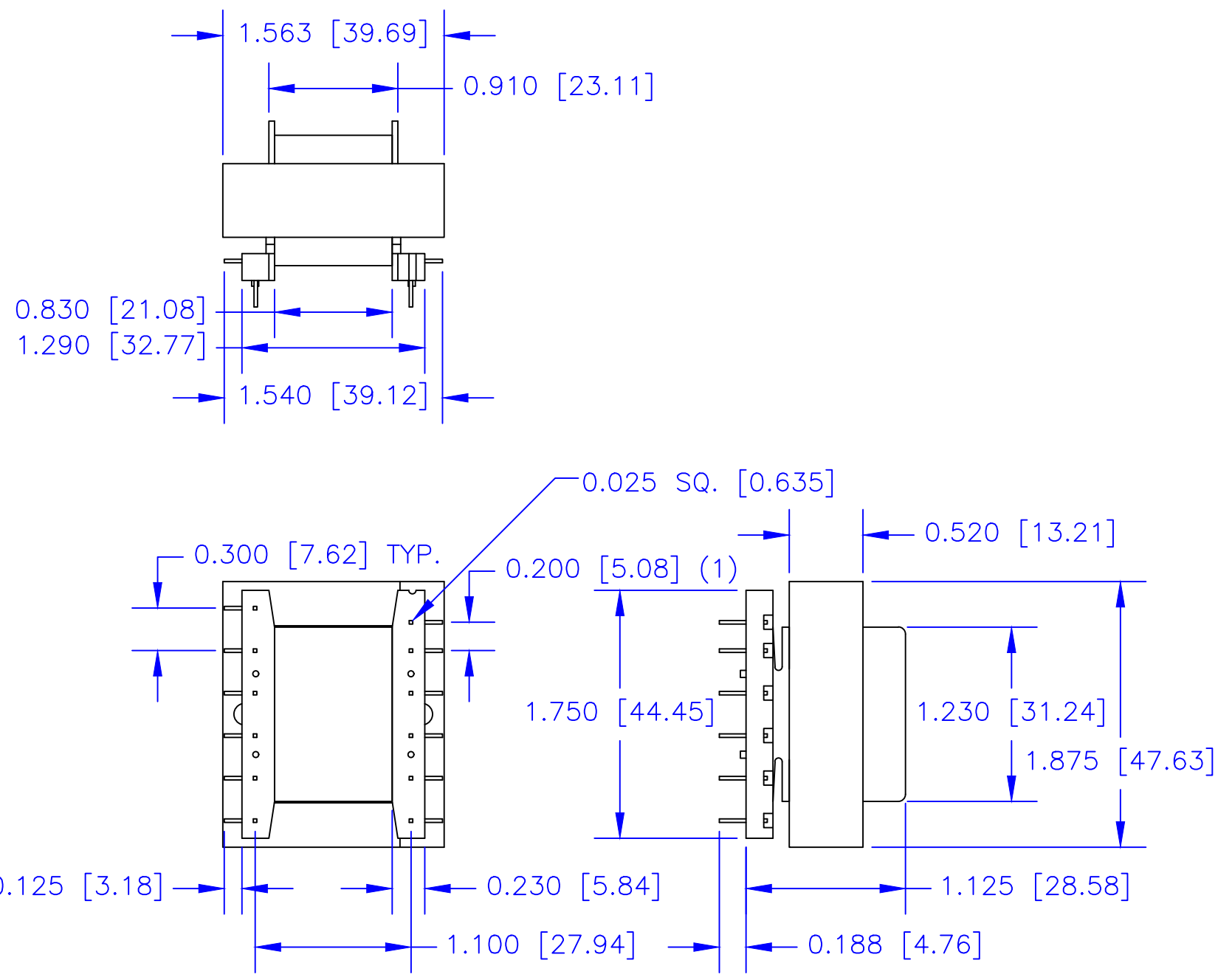

PCB MOUNTING SPECIFICATIONS

- PCB NOTES:**
- PIN 1 IS OFFSET FOR KEYING.
 - PAD SHOULD BE AT LEAST 150 MIL. DIA.
 - DRILL TROUGH HOLES SHOULD BE 55 MIL. DIA. AFTER 2 OZ. COPPER PLATED THROUGH HOLE.

**PIN ORIENTATION
(COMPONENT LAYER)**

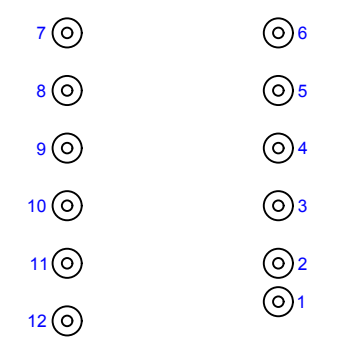

**FOOTPRINT
(COMPONENT LAYER)**

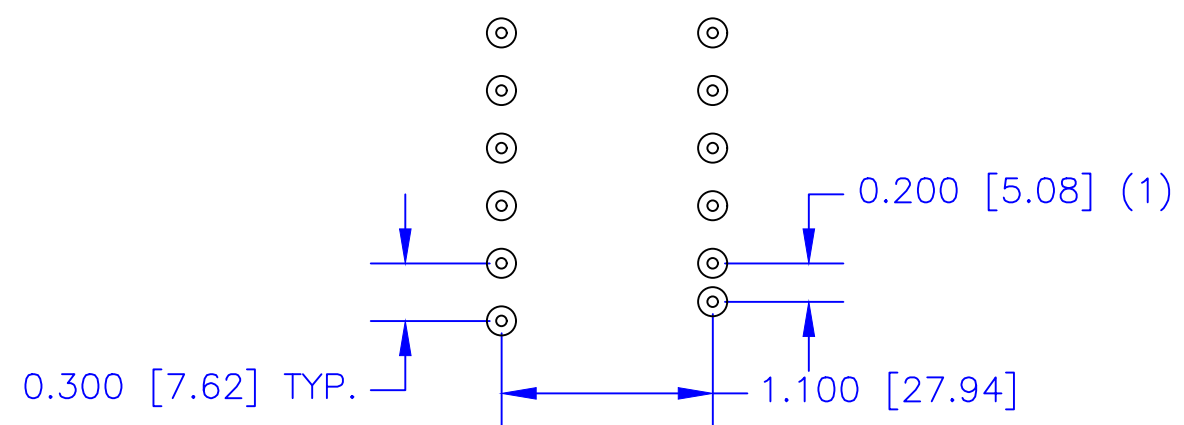

****NOTES: UNLESS OTHERWISE SPECIFIED!**

- All material is UL listed.
- All material are to be RoHS compliant.
- Bobbin: Nylon 6/6 30% glass filled, Class B, Flammability 94HB UL E184262.
- Magnet Wire: Class B, UL E32638, Gauge depending on the transformer design specifications requirement.
- Finish Tape: Polyester film tape, Class 130°, dielectric strength 5000 volts, UL E17385, guide OANZ2.
- Core Material: Depending on the transformer design specifications requirement
- Termination: 12 pin PC.
- Mounting: PCB mounted.
- Finish: Styrenated alkyd electrical varnish, air cured, UL E63933.

DIMENSIONS ARE IN INCHES [MILLIMETERS]. X.XXX = ±0.010 X.XX = ±0.03 ANGLES = ±0.05 UNLESS OTHERWISE SPECIFIED		EDCOR Electronics 7130 National Parks Highway, Carlsbad, NM 88220 Voice: (575) 887-6790 www.edcorusa.com	
DRAWING BY Brian Weston		Date 1/2003	
CHECKED BY Brian Weston		Date 1/2003	
APPROVED BY Larry Weston		Date 1/2003	
SIZE C		FSCM NO. 15000-EI625-050-P12	
SCALE: 1:1		DWG NO. 15000-EI625-050-P12	
©2015 EDCOR Electronics		SHEET: 1 of 1	