

REVISIONS				
ZONE	REV	DESCRIPTION	DATE	APPROVED

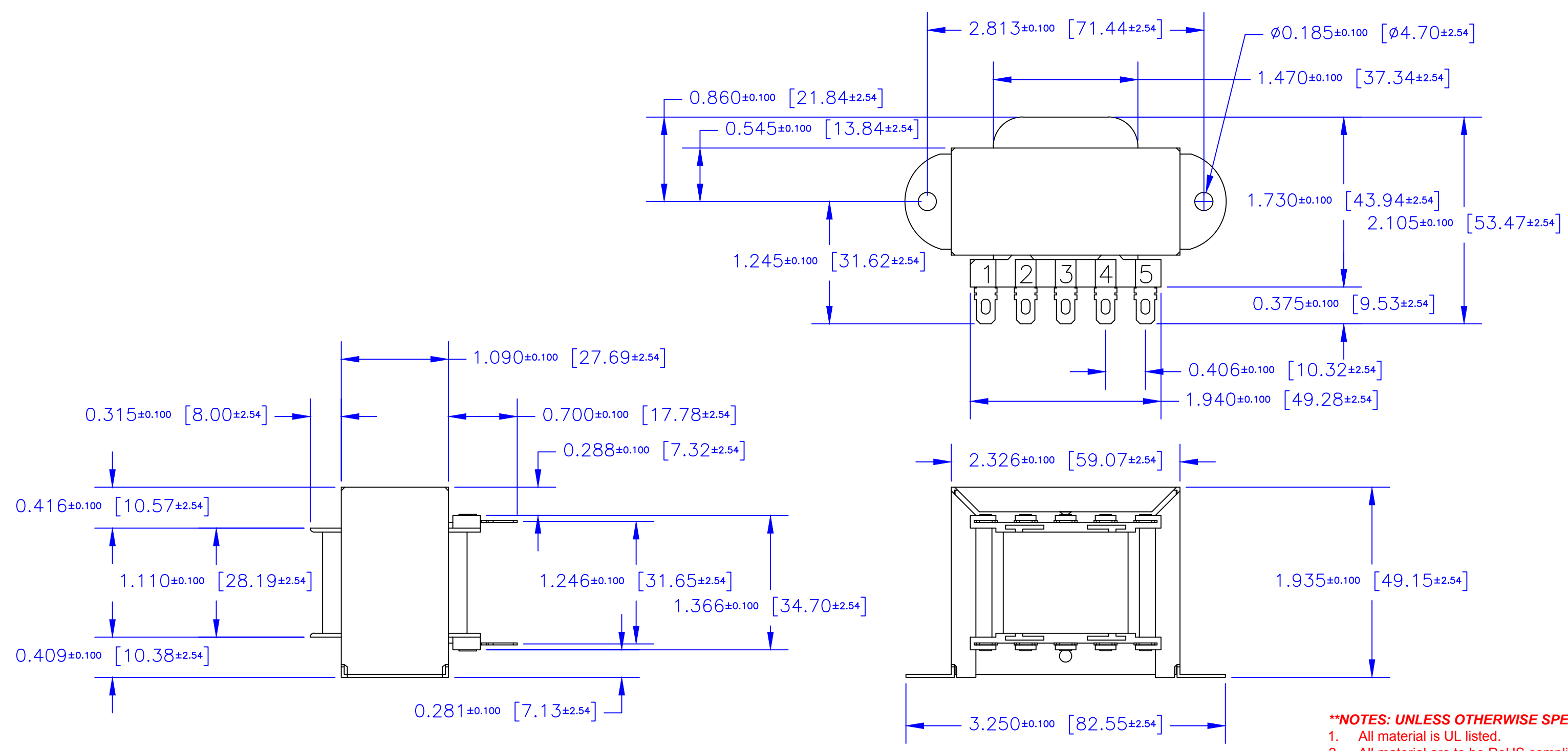

- \*\*NOTES: UNLESS OTHERWISE SPECIFIED!**
1. All material is UL listed.
  2. All material are to be RoHS compliant.
  3. Bobbin: Nylon 6/6 30% glass filled, Class B, Flammability 94HB UL E184262.
  4. Magnet Wire: Class B, UL E32638, Gauge depending on the transformer design specifications requirement.
  5. Finish Tape: Polyester film tape, Class 130°, dielectric strength 5000 volts, UL E17385, guide OANZ2.
  6. Core Material: Depending on the transformer design specifications requirement.
  7. Termination: 0.1875" quick disconnects.
  8. Mounting: Zinc plated steel horizontal channel/frame.
  9. Finish: Styrenated alkyd electrical varnish, air cured, UL E63933.

DIMENSIONS ARE IN INCHES (MILLIMETERS). X.XXX = ±0.010 X.XX = ±0.03 ANGLES = ±0.05 UNLESS OTHERWISE SPECIFIED		<b>EDCOR Electronics</b> 7130 National Parks Highway, Carlsbad, NM 88220 Voice: (575) 887-6790 <a href="http://www.edcorusa.com">www.edcorusa.com</a>		
DRAWING BY		Date		
Brian Weston		4/2003		
CHECKED BY		Date		
Brian Weston		4/2003		
APPROVED BY		Date		
Larry Weston		4/2003		
SIZE	FSCM NO.	DWG NO.	REV	
C		15000-EI075-100-18		
SCALE: 1:1		©2015 EDCOR Electronics	SHEET: 1 of 1	