

MAXIMIZER

Gas Industrial Ovens

MODEL CW61I

General Features:

- **Quality Construction** for long life
- **Stainless Steel Front Standard**
Stainless top & sides available (T430)
- **Heavy duty steel deck** with flanged sides (16A)
- **4-Cell "Power-Pak" Burner System** for better distribution of heat and better baking ability
- **Thermostat(s)**
250° - 550° standard
300° - 650° optional
- **Space Saver**
Only 50" wide
- **Stackable**
Multiple options for flexibility
- **Aluminized Interior Standard**
- **Easily Serviceable**
Most controls can be replaced from the front of the unit
- **Warranty**
One year parts and labor
- **Power**
Gas - LP or NAT
- **Specific Features** of the CW61I listed on back



GAS FIRED



Steel Decks

Steel Deck
Baffle
Burner

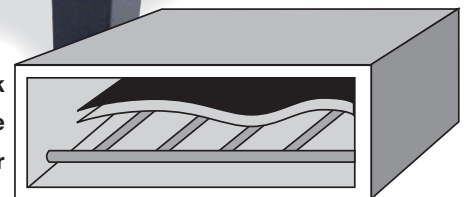

"Power-Pak" 4-Cell Burner System

MORE FOR LESS

More Heating Space per Floor Space
More Heating Capacity per Sales Dollar
More Performance per Gas Dollar

 **Peerless**
Commercial and Industrial Ovens

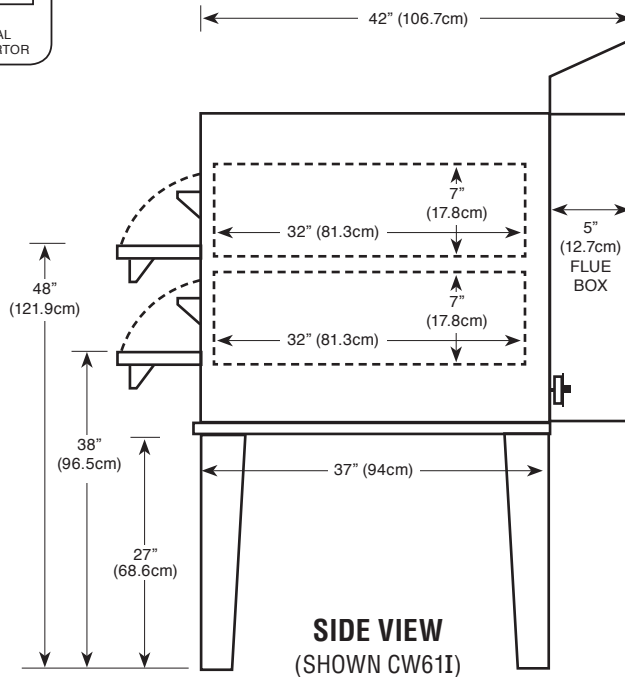
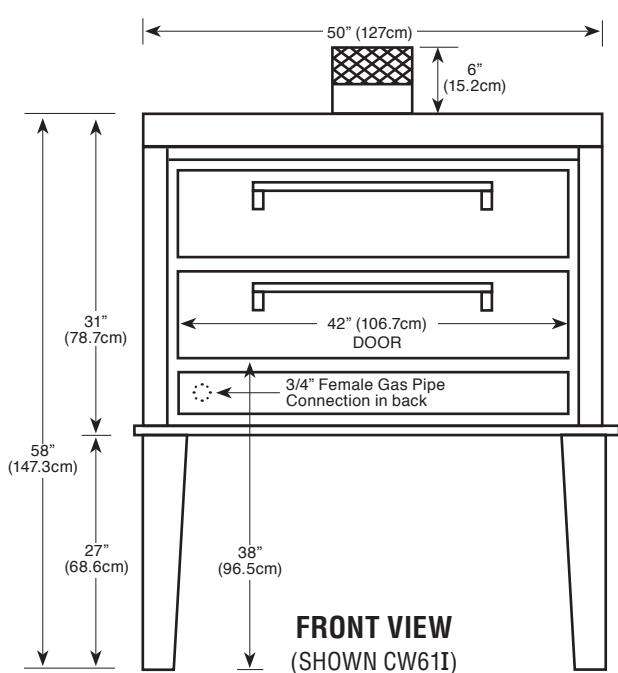
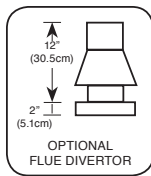

Floor space	50" (127cm) wide x 42" (106.7cm) deep* x 58" (147.3cm) high
Shelf size	42" (106.7cm) wide x 32" (81.3cm) deep x 7" (17.8cm) high
Shipping weight	550 lbs (249.6kg)
Capacity	Four 18"x26" trays per section
Gas	Maximum 60,000 BTU input
Opening required for installation: 32"	* Handle adds 2.5"(6.4cm) to depth



Adjustable Legs

Durable Construction

The CW61I is built with *prime 20-gauge cold-rolled top and sides* with a 14-gauge base. The *interior is made of Armco Type 1, 20-gauge aluminized steel*. The CW61I comes standard with stainless steel front, or optional all stainless steel finish. The stainless steel is made of high quality, 18-gauge 430 stainless; the door interior is 18 gauge stainless.

Energy Efficiency

The CW61I features our *new energy-saving "Power-Pak" 4-cell burner system* and our *unique baffle system*. These make our ovens highly efficient and eliminate hot spots. The *heavily insulated walls*, coupled with our *special vent system*, reduces heat loss and keep your gas dollars from going up the stack. The CW61I is powered by 60,000 highly efficient BTUs which *increases its efficiency and recovery rate*.

Capacity

The CW61I deck size measures 42"x32"x7" (2). The CW61I will hold four (4) 18"x26" trays. Heating time will vary according to product.

Space Saver

Because the controls are under the doors, the CW61I requires *less installation space* than our competition. This enables you to free up valuable workspace. The actual width needed is mere 50" for two (2) 42"x32" decks, almost a foot less than the competition. The CW61I *can convert into a CW62ISC by stacking*, either initially or after our business grows. This option gives you four (4) 42"x32" decks in only 56" of space.

Design Plus

The CW61I has the *controls in lower front for ease of operation and space savings*. This also places the controls in their own *air-conditioned area* so they are not affected by outside influences. In addition, the CW61I is *totally thermocoupled* and allows you to replace individual parts as opposed to throwing away the whole system.

