

moda

KIAN FREESTANDING BATH

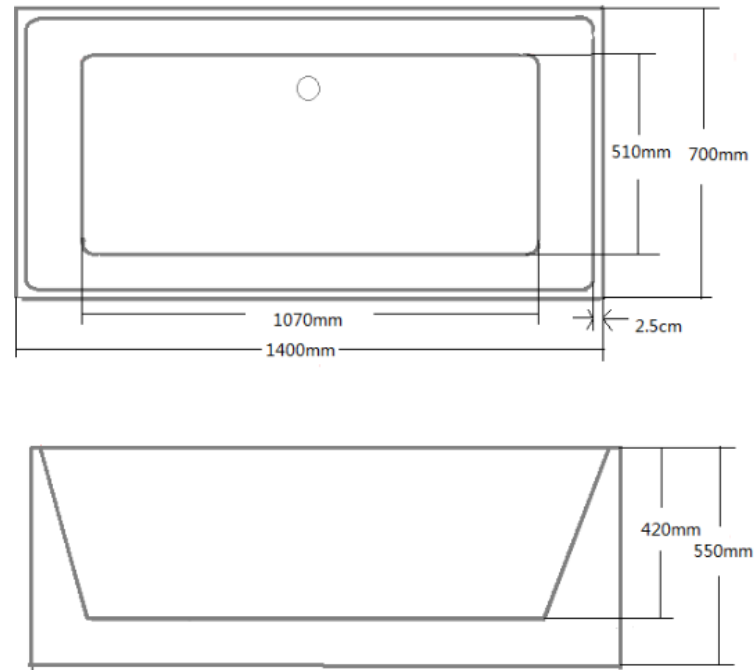

- 25mm Profile 8mm Thick Acrylic reinforced with fibreglass
- Code: ST05D
- 10yr Warranty
- Smooth gloss white finish
- Non Slip
- Polished chrome popup waste kit installed
- Adjustable galvanised metal legs for levelling
- 1mtr 40mm Flexible waste hose for easy installation
- Galvanised supporting under carriage
- Net Weight 65Kgs
- Crated size L+100, W+100, H+250mm
- Gross Weight 80kgs
- Australian Standard (SAI)
- AS/NZS 3718:2003



Our Beautiful Freestanding Bath Series are constructed of fibreglass reinforced acrylic are non slip and smooth to the touch.

The last bastion of privacy, a space of peace and tranquility, your Bathroom. Enjoy the look and feel of our European Bathroom fittings and fixtures. Designed and made to the highest International standards.



As part of MODA commitment to quality products. Information provided in this data sheet is representative of the actual product available at the time of printing. Due to our commitment to continuous product design and development, the designs and specifications depicted are subject to change without notice. Please confirm all particulars with your MODA sales consultant prior to purchase. Each product is covered by a limited warranty. Please see our website for full terms and conditions. This drawing remains the property of MODA and should not be copied or distributed without MODA consent. © 2010 All Dimensions are approximate in mm and are not to scale and can be changed without notice.

www.modabathware.com