

ELLIPSIS FREESTANDING

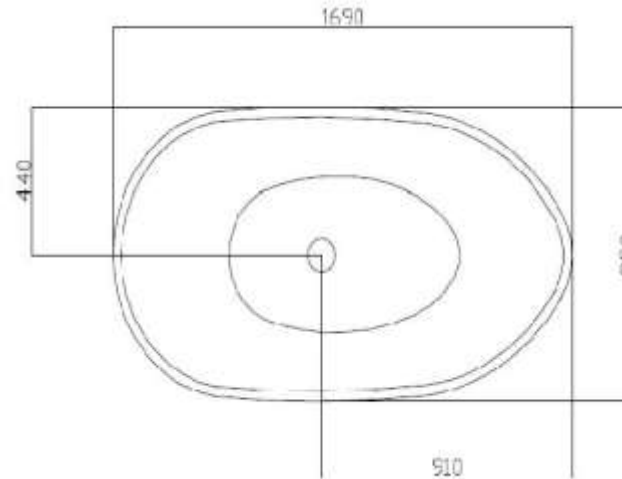

- Code: ST-03A
- 25mm Profile 8mm Thick Acrylic reinforced with fibreglass
- 10yr Warranty
- Smooth gloss white finish
- Non Slip
- Polished chrome popup waste kit installed
- Adjustable galvanised metal legs for levelling
- 1mtr 40mm Flexible waste hose for easy installation
- Galvanised supporting under carriage
- Net Weight 65Kgs
- Crated size L+100, W+100, H+250mm
- Gross Weight 105kgs
- Australian Standard (SAI)
- AS/NZS 3718:2003



Our Beautiful Freestanding Bath Series are constructed of fibreglass reinforced acrylic are non slip and smooth to the touch.

The last bastion of privacy, a space of peace and tranquility, your Bathroom. Enjoy the look and feel of our European Bathroom fittings and fixtures. Designed and made to the highest International standards.

