

# moda

**Code:** A-138A  
**Material:** Stone - 70% Limestone Composite  
**Size:** W 1600 x D 800 x H 580 mm  
**Warranty:** 10 Years

### Features:

- Smooth matt white finish (gloss by custom order)
- Italian Design & Engineering
- Superior Heat Retention
- Pop Up Waste – Installed
- 1mtr Flexible Drain Hose for Easy Installation (DN40)
- Scratch and Stain resistance
- Adjustable Leg Height For Levelling
- Repairable Material
- Australian Standard (SAI) AS/NZS 3718:2003

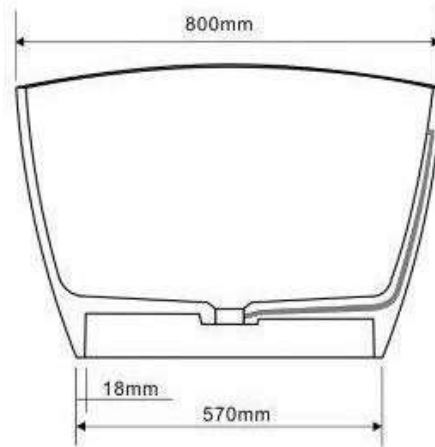
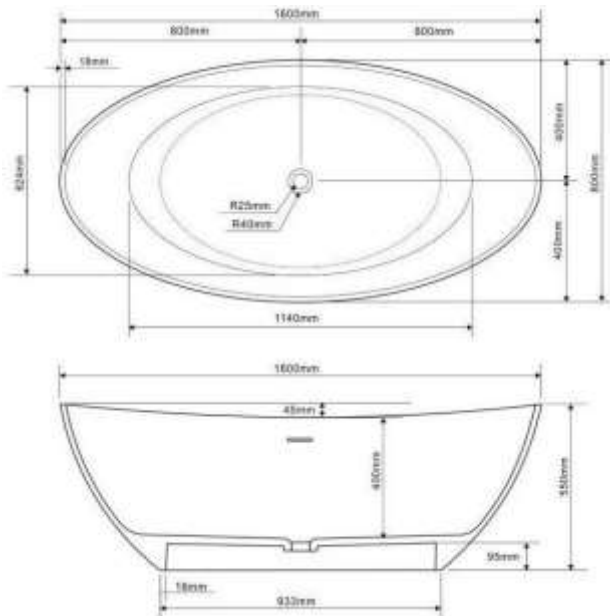

## FELICIA



### Specifications:

- Net Weight: 160Kg
- Crate size:  
L 1700, W 900, H 575mm
- Gross Weight: 175Kg

The last bastion of privacy, a space of peace and tranquility, your Bathroom. Enjoy the look and feel of our European Bathroom fittings and fixtures. Designed and made to the highest international standards.



As part of MODA commitment to quality products. Information provided in this data sheet is representative of the actual product available at the time of printing. Due to our commitment to continuous product design and development, the designs and specifications depicted are subject to change without notice. Please confirm all particulars with your MODA sales consultant prior to purchase. Each product is covered by a limited warranty. Please see our website for full terms and conditions. This drawing remains the property of MODA and should not be copied or distributed without MODA consent. © 2010 All Dimensions are approximate in mm and are not to scale and can be changed without notice.

[www.modabathware.com](http://www.modabathware.com)