

**Code:** A-134

**Material:** Isostone - 70% Limestone Composite

**Size:** W 1860 x D 780 x H 580 mm

**Warranty:** 10 Years

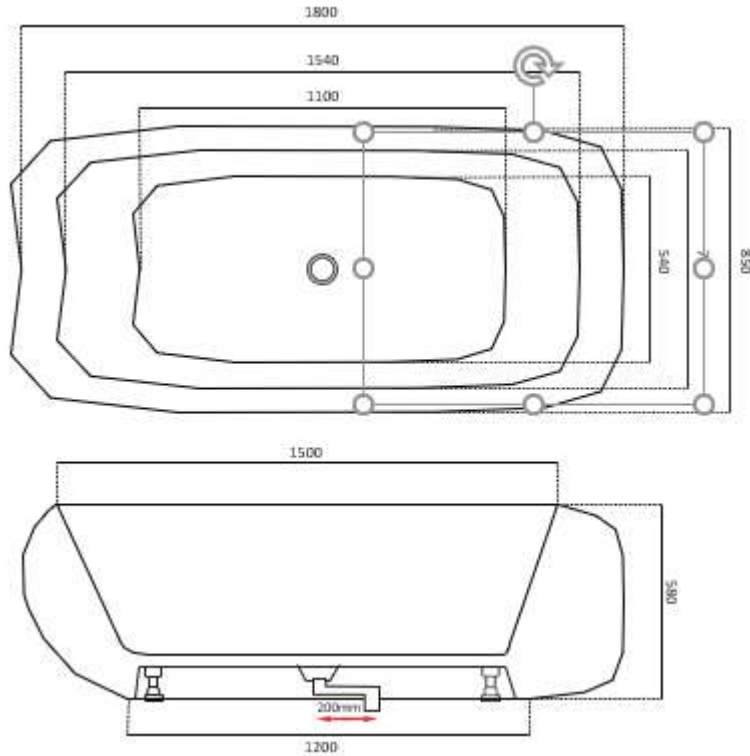

## Ellie



### Features:

- Smooth solid matt white finish (gloss by custom order)
- Italian Design & Engineering
- Superior Heat Retention
- Pop Up Waste - Installed
- 1mtr Flexible Drain Hose for Easy Installation (DN40)
- Galvanised Metal Base Support
- Adjustable Leg Height For Levelling
- Scratch and Stain resistance
- Repairable Material
- Australian Standard (SAI) AS/NZS 3718:2003

### Specifications:

- Net Weight: 165 Kg
- Crate size:  
L 1980, W 1090, H 880mm
- Gross Weight: 200 Kg

The last bastion of privacy, a space of peace and tranquility, your Bathroom. Enjoy the look and feel of our European Bathroom fittings and fixtures. Designed and made to the highest international standards.

