



FLAME  **PRO**[®]

TESUCO
TECHNICAL SUPPLIES COMPANY



**Air-Propane
Equipment**

QUALITY GAS EQUIPMENT

www.tesuco.com.au

We Thank You For Choosing Our Quality Air-Propane Equipment

Beginning in 1988, Tesuco® has established itself as a specialist equipment supplier for all gas welding, heating and cutting applications. Tesuco® is proud to be 100% Australian owned and has been quality endorsed by SAI Global to the AS/NZS ISO 9001 Standard since 1995.

This booklet introduces you to our range air-propane equipment for heating available through our extensive distributor network around Australia / New Zealand and other countries.



Only trained operators may use this equipment.



Tesuco Pty Ltd

Head Office Unit 12, 110-120 Silverwater Road, Silverwater NSW 2128

Hours Mon - Fri 8am - 5pm

Phone +61 2 9737 9937

Sales..... sales@tesuco.com.au

Orders..... orders@tesuco.com.au

Website..... www.tesuco.com.au



Scan QR code to view our complete range of gas equipment.

Our name Tesuco® comes from Technical Supplies Company.

Australian / New Zealand / International Standards

There are many standards and codes of practices covering gas equipment. Tesuco® gas equipment conforms to Australian / New Zealand standards where they are published and if not, follows international standards.

The torch handle, burners or nozzles are covered by an international standard. International standard EN ISO 9012, Gas Welding Equipment - Air-Aspirated hand blowpipes - specifications and test.

The regulator RC1RLP4-3 is covered by AS4267. The gaugeless mini regulators RCLPM4 and K44301 have been specially designed for air propane use only and are not covered in the current Australian standard. The Gas Stop anti-leak regulator is covered by international standard EN16129.

Hoses for air propane are covered by AS/NZS1869 - Hose and hose assemblies for liquefied petroleum gases (LP Gas), natural gas and town gas.

Note: LP Gas hose for mixed gases (oxygen and propane) are covered by AS/NZS1335 standard.

LpG Regulators

Tesuco® has three styles of regulators to suit the burner flow rate of LpG from the cylinder.

The RC1RLP4-3 is designed for larger diameter burners and manifold burner applications.

The mini regulator RCLPM4 and K44301 has a maximum flow rate of 6 kg/H of LpG at around 400kPa / 4Bar.

The Gas Stop regulator is unique to Tesuco® as it is the only anti-leak regulator system on the market.



LPG Withdrawal Rates

As with acetylene, flow rate for LPG is restricted by the size of the cylinder used. For example, the maximum continuous draw off @ 21°C for a 45 kg cylinder is 56.6 L/min. As a result, the maximum flame setting may not be reached if the supply of LPG does not match the burner capacity of gas consumption. This means that the maximum flame setting can not be reached therefore a small burner is recommended. Ensure you know the LPG withdrawal rate of the cylinder size you are using.

Torch Handle and Burners

All Flame Pro® handles and burners comply with International standard ISO-9012.



Other burners are connected via a neck tubes.

Hoses

All Flame Pro® hoses comply with Australian / New Zealand standard AS/NZS1869. All hose sizes have a 8 mm ID and range in length from 2 to 20 meters. All hose fittings are factory fitted and tested. The hoses are independently certified by AGA - Australian Gas Association.



Gas Stop hoses have a unique "hose in a hose system". International standards EN 16436-1 (class 2) is followed and is certified by DVGW in Germany

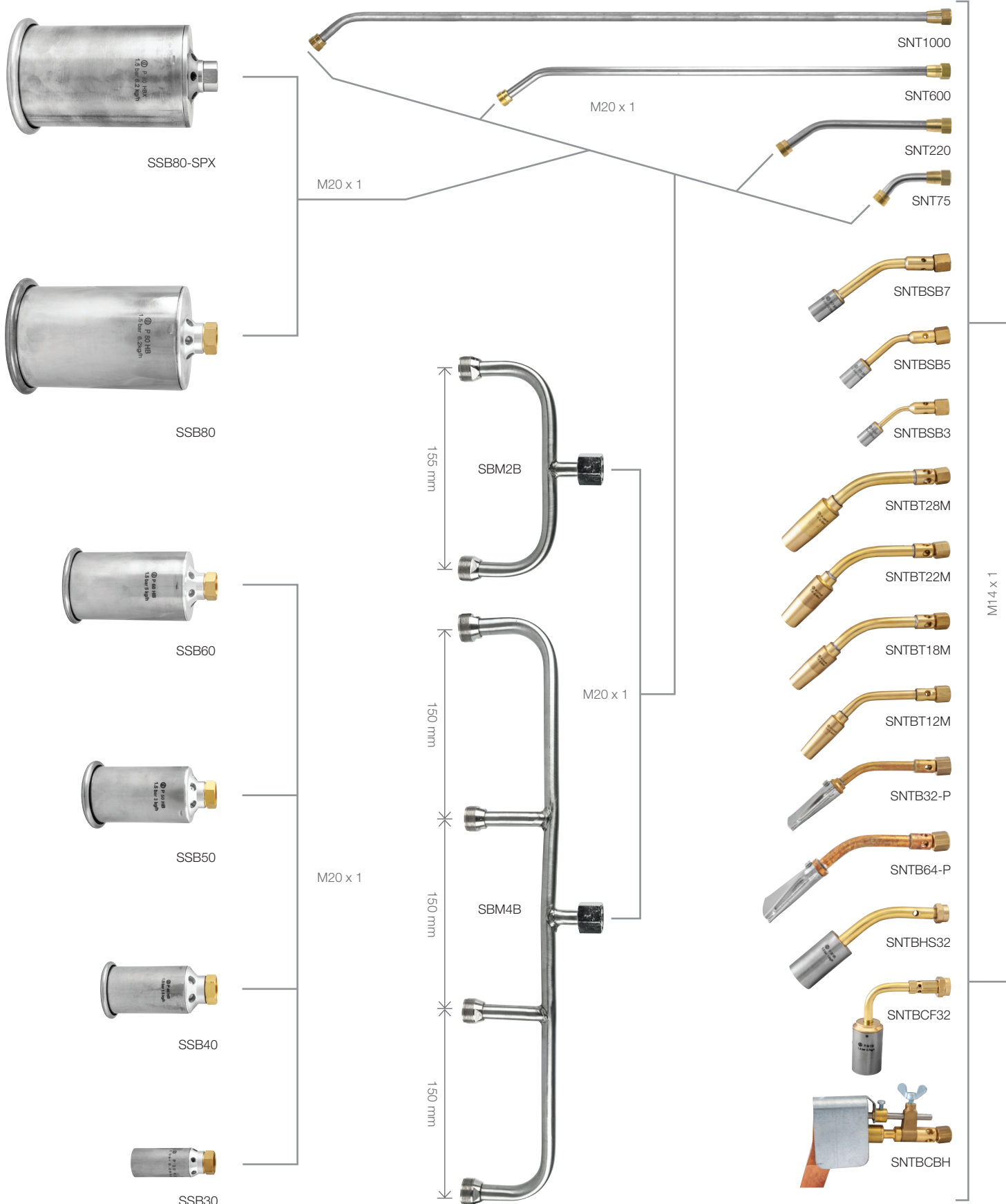

Air-Propane Combination Chart

FLAMEPRO

TESUCO
TECHNICAL SUPPLIES COMPANY



THP01



THP02



3/8" BSP LH

- SH2-3/8
- SH4-3/8
- SH6-3/8
- SH10-3/8
- SH20-3/8



3/8" BSP LH
POL
Type 21

RC1RLP4-3

Note: Recommended for high flow rates when using SSB60 or higher burners or the manifold SBM2B or 4B.



3/8" BSP LH

RCLPM4

POL Type 21

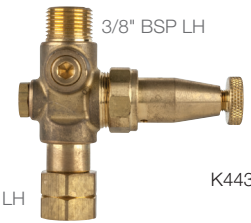

3/8" BSP LH

K44301

3/8" BSP LH

GAS STOP ANTI-LEAK SYSTEM



SHP01-OM



SHP02-OM

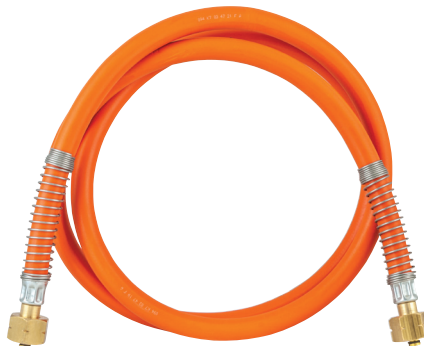

22 x 1.5 LH FM

22 x 1.5 LH FM

- SOMGSH 2
- SOMGSH 4
- SOMGSH 6



POL Type 21

M22 x 1.5 LH M

SOGSPOL

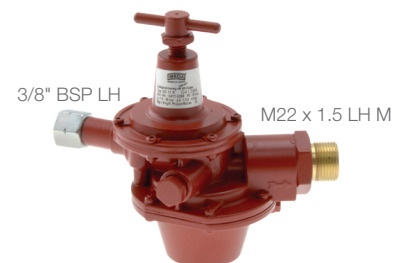

3/8" BSP LH

M22 x 1.5 LH M

SOGS38



REGULATORS

The AS 4267 compliant RC1RLP4-3 model LPG regulator has a high flow rate and is designed for use with the complete range of burners and manifolds. Rear entry design ensures the regulator will fit all cylinders. Fully adjustable pressure range from 0 – 400 kPa with a readable delivery pressure gauge fitted with a gauge protector. Maximum flow rate of 52 kg/h.

SPECIFICATIONS	RC1RLP4-3
Inlet connection	POL Type 21
Outlet connection	G3/8"
Flow rate	28.5 m ³ /hr

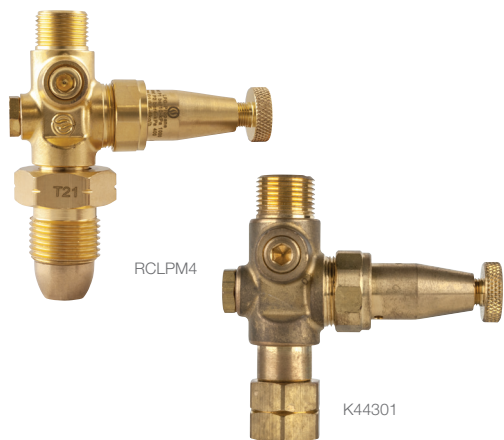

MINI REGULATOR

The LPG mini regulator has two designs. The RCLPM4 model is designed with a "POL" type inlet connection. The K44301 model is designed with a 3/8" inlet connection. Made from solid brass it is compact in size to fit small cylinders. The outlet pressure is adjustable to 400 kPa with a maximum flow rate of 6 kg/h. Gaugeless regulators are currently outside the scope of AS 4267. These regulators can only be used on Air-Propane applications listed in this brochure.

SPECIFICATIONS	RCLPM4	K44301
Inlet connection	POL Type 21	G3/8" LH FM
Outlet connection	G3/8" LH M	G3/8" LH M



SH10-3/8

HOSE SET

Complete

Hoses are manufactured to AS/NZ 1869 standard, hose and hose assemblies for liquefied petroleum gases (LP Gas), natural gas and town gas, AGA* certified product Certification N^o: 8076. All hose assemblies are factory fitted with G3/8" LH connections designed to fit standard air propane equipment.

*AGA – The Australian Gas Association

SPECIFICATIONS	SH2-3/8	SH4-3/8	SH6-3/8	SH10-3/8	SH20-3/8
Size (m)	2	4	6	10	20
Hose I.D (mm)	8				
Connection	G3/8" LH FM				
MPA (kPa)	2.6 (2,600)				

i Due to AGA approval, hoses cannot be repaired if damaged.



TORCH HANDLE

These torch handles are ergonomically designed with a shock resistant grip which fits comfortably and securely into the hand. An integrated solid brass control valve and adjustment knob allows fine adjustment of the flame. Tesuco® also supplies an economiser torch handle with an independently adjustable pilot flame control valve. The economiser can also be set as a “deadmans” lever, to shut off the flow of gas to the burner. This feature saves both gas and work time, as gas consumption is reduced by up to 97% when the economiser valve is in use. The Flame Pro® torch handle fully complies with EN ISO 9012

SPECIFICATIONS	THP01	THP02
Type	Standard	Economiser
Inlet connection (mm)	G3/8" LH	
Outlet connection	M14 x 1	
Operating Pressure (kPa)	150 - 400	



VORTEX Neck Tube Burners

Produce a cyclone rotating vortex flame to enable target heat to be applied to the working surface. They are ideally suited for pipe soldering, soft soldering and brazing, bending tubes, small forging, thawing frozen pipes, annealing and tempering.

SPECIFICATIONS	SNTBT12M	SNTBT18M	SNTBT22M	SNTBT28M
Size for copper tubes approx (mm) Ø	12	18	22	28
Inlet connection (mm)	M14 x 1			
Max. flame length (cm)	10	12	14	17
Gas consumption (g/h @ 150 kPa)	120	150	250	360
Heat effect (kJ)	1,460	1,830	3,050	4,390
Engraving Marks	P-12 Ⓢ 1.5-2.5 BAR	P-14 Ⓢ 1.5-2.5 BAR	P-17 Ⓢ 1.5-2.5 BAR	P-20 Ⓢ 1.5-2.5 BAR



SNTBSB3

ULTRA PINPOINT

Neck Tube Burners

Extremely efficient fine and precise needle flame with a pronounced inner blue cone. This is an excellent burner for goldsmiths, electrical soldering, small brazing and silver soldering.

SPECIFICATIONS	SNTBSB3	SNTBSB5	SNTBSB7
Size (mm)	3	5	7
Inlet connection (mm)	M14 x 1		
Max. flame length (cm)	15	20	25
Gas consumption (g/h @ 150 kPa)	35	115	150
Heat effect (kJ)	420	1,400	1,830



SNTB32-P

FLAT FLAME

Neck Tube Burners

The intense broad, flat, fantail flame is designed for removing paint and varnishes from timber and metal surfaces, grain patterning on timber, adhesive removal, surface drying and ski waxing.

SPECIFICATIONS	SNTB32-P	SNTB64-P
Size (mm)	32	64
Inlet connection (mm)	M14 x 1	
Max. flame length (cm)	10 x 10	20 x 20
Gas consumption (g/h @ 150 kPa)	115	250
Heat effect (kJ)	1,400	3,050



SOFT FLAME HEAT SHRINK

Neck Tube Burner

This efficient, soft sweeping, windproof flame with a pronounced yellow tip is visible when working in daylight. Applications include medium and heavy walled insulated tubing for electrical and telecommunication, cable termination systems and busbar tubing.

SPECIFICATIONS	SNTBHS32
Size (mm)	32
Inlet connection (mm)	M14 x 1
Max. flame length (cm)	55
Gas consumption (g/h @ 150 kPa)	800
Heat effect (kJ)	9,250



COMPOUND FLAME

Neck Tube Burner

The compound flame burner design is ideal for melting metals, glazing work, hobby work, adhesive removal and other applications.

SPECIFICATIONS	SNTBCF32
Size (mm)	32
Inlet connection (mm)	M14 x 1
Max. flame length (cm)	30
Gas consumption (g/h @ 150 kPa)	1,500
Heat effect (kJ)	17,350

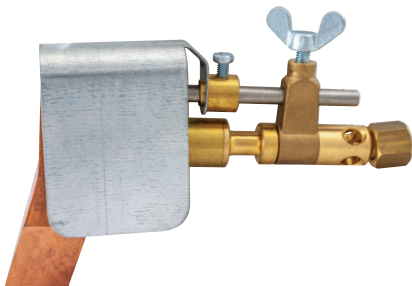

SOLDERING

Neck Tube Burner

Applications include heat shrinking, adhesive removal, bending plastic tubes, insulation work and soldering. The soldering burner is fitted with a 350 g hammer shape bit. Different bits available in differing weights, either straight or chisel, to suit the different soldering applications.

SPECIFICATIONS	SNTBCBH
Inlet connection (mm)	M14 x 1 RH FM
Gas consumption (g/h @ 150 kPa)	150

SCBB250



SCBS250



SOLDERING BITS

The solder bits are for use with the soldering burner attachment and allow for different types of soldering in different positions.

SPECIFICATIONS	SCBB250	SCBB350	SCBS250	SCBS350
Size (g)	250	350	250	350
Shape	Hammer	Hammer		
Type			Straight	Straight



SSB60

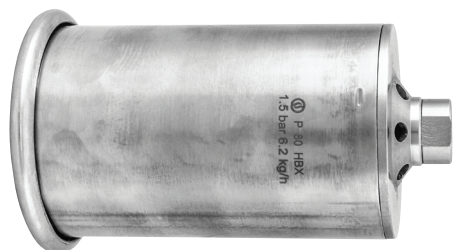

SSB80-SPX

STANDARD FLAME

High Capacity Burners

Highly effective full bodied windproof flames, suitable for those applications requiring high manageable heat output to a large surface area. They are ideal for preheating steels prior to welding, flooring, roofing and asphalt work, ceramic tile removal and automotive applications.

SSB80-SPX body, base plate and nut are fully stainless steel.

SPECIFICATIONS	SSB30	SSB40	SSB50	SSB60	SSB80	SSB80-SPX
Size (mm)	30	40	50	60	80	80
Inlet connection	M20 x 1 FM					
Max. flame length (cm)	20	40	50	60	80	80
Gas consumption (g/h @ 150 kPa)	600	2,000	3,000	5,000	6,200	6,200
Heat effect (kJ)	6,954	24,400	26,230	61,600	85,400	85,400

Gas consumptions based at a supply pressure of 150 kPa / 1.5 Bar. These figures may vary based on gas supply from the cylinder. Burners used in a manifold should match the cylinder supply or the burners will not operate to the maximum flame setting - In this case, small burners sizes are recommended. A standard 45 kg LPG cylinder has a maximum draw off rate of approximately 56.6 L/min - Refer to respective gas companies published data for details.

Guide Based on 45 kg Cylinders

- Requires 1 x 45 kg Cylinder
- Requires 2 x 45 kg Cylinders
- Requires 4 x 45 kg Cylinders

	SSB30	SSB40	SSB50	SSB60	SSB80	SSB80-SPX
Gas consumption at 1.5bar (kg/hr)	0.6	2	3	5	6.2	6.2
Effective l/min consumption	5.5	18.2	27.3	45.5	56.4	56.4
Gas consumption						
Single burner	5.5	18.2	27.3	45.5	56.4	56.4
Twin manifold	11	36.4	54.6	91	112.8	112.8
Quad manifold	22	72.8	109.2	182	225.6	225.6

Figures are a guide only.

NECK TUBES

Stainless Steel

Designed for use with the standard flame compound burners, SSB30, SSB40, SSB50, SSB60, SS80 and SSB80-SPX. Longer lengths are available to increase the distance between the burner and the handle reducing the effect of radiant heat back onto the hand during operation. To achieve the maximum flame setting, it will depend on the gas supply and the burners size you fit to the manifold. The flame maybe restricted by the lack of gas.

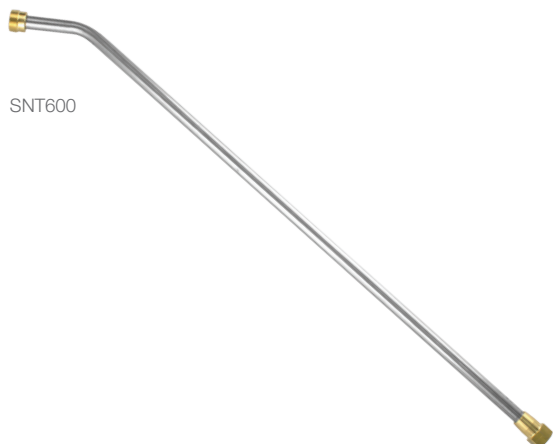

SNT600

SPECIFICATIONS	SNT 75	SNT220	SNT600	SNT1000
Size (mm)	75	220	600	1000
Inlet connection (mm)	M14 x 1 RH FM			
Outlet connection (mm)	M20 x 1 RH M			

Air-Propane Heating Kits

FLAMEPRO

TESUCO
TECHNICAL SUPPLIES COMPANY

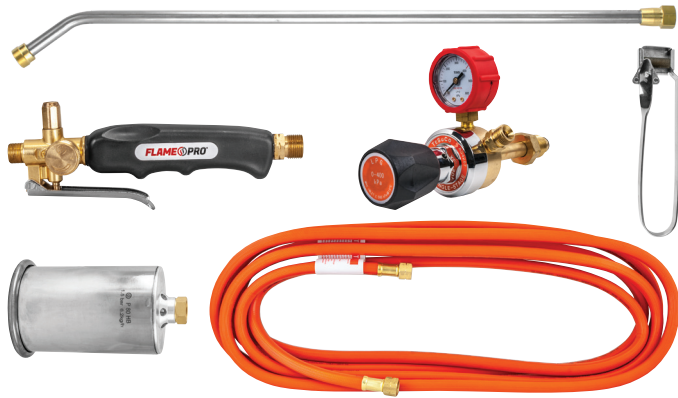

STK41EXTRA

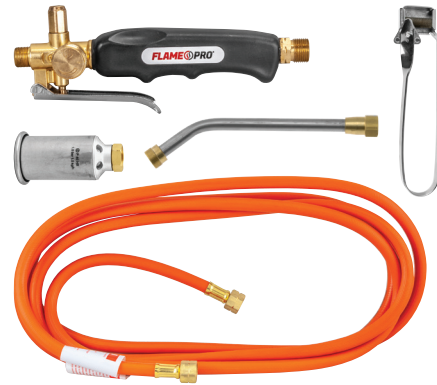

STK442

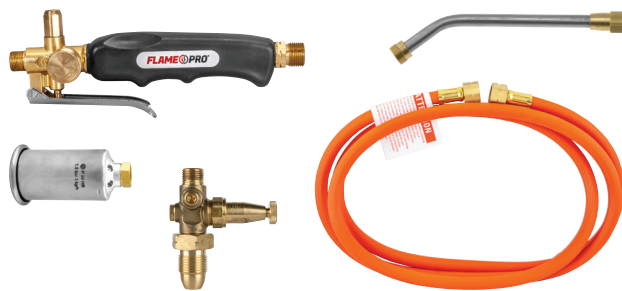

STKC

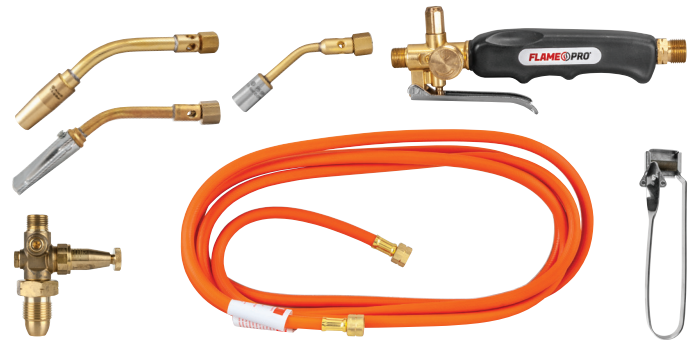

STKH

PART NO	DESCRIPTION	STK41EXTRA	STK442	STKC	STKH
THP02	Torch handle Economiser	•	•	•	•
SNT220	Neck Tube 200 mm Stainless Steel		•	•	
SNT600	Neck Tube 600 mm Stainless Steel	•			
SNTBSB5	LPG Pin Point Flame Burner 5 mm				•
SNTBT18M	LPG Vortex Burner 18 mm				•
SNTB32-P	LPG Flat Flame Burner 32 mm				•
SSB40	High-Capacity Burner 40 mm		•		
SSB50	High-Capacity Burner 50 mm			•	
SSB80	High-Capacity Burner 80 mm	•			
SH2-3/8	LPG Hose Set – 2 m			•	
SH4-3/8	LPG Hose Set – 4 m		•		•
SH6-3/8	LPG Hose Set – 6 m	•			
RC1RLP4-3	LPG Regulator	•			
RCLPM4	Mini Regulator POL			•	•
GWTF	Triple Flint Lighter	•	•		•

QUICK CONNECTIONS

Quick-Action Couplers

Allows for safe interruption of the gas flow by automatic gas cut-off when disconnection for the pin.

Independently tested by BAM to EN 561, ISO 7289 ensures the product is manufactured to the highest standards by Ibeda. The coupling units are sold complete with the pins and spare pins can be purchase separately.

Note: Threads are in accordance with EN 560 and ISO 3253

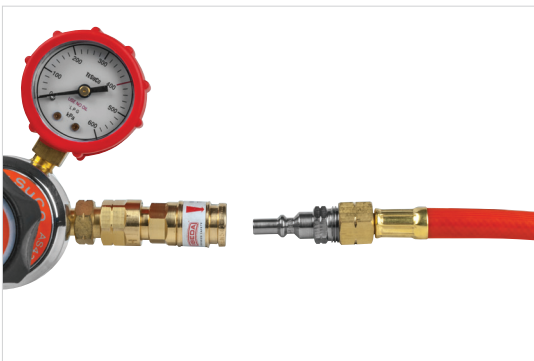

REGULATOR END

Fuel Gas

The gas is stopped from flowing into the hose once the coupling pin is released. This allows you to safely remove the hose set for transport or storage.

SPECIFICATIONS **QFDF3M3**

Inlet connection	G3/8" FM
Outlet connection	Pin G3/8" M

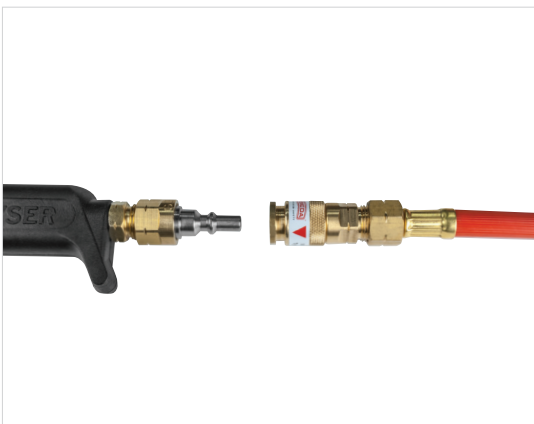

TORCH HANDLE

Fuel Gas

Designed to stop the flow of gas once the coupling is released from the pin, this will automatically cut-off the supply to the torch handle and retain the gas in the hose. The coupler also allows the torch handle to rotate without kinking the hose.

SPECIFICATIONS **QFDM3F3**

Inlet connection	G3/8" M
Outlet connection	Pin G3/8" FM

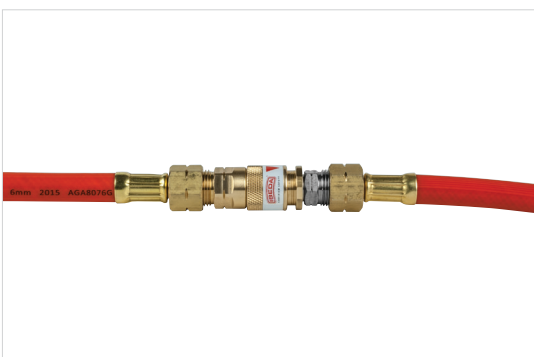

HOSE JOINER

The Quick Action Hose Joiner allows you to extend the hoses length quickly. Having smaller length of hoses make it easy to control the hose from becoming tangled or kinked.

SPECIFICATIONS **QFDM3M3**

Inlet connection	G3/8" M
Outlet connection	Pin G3/8" M

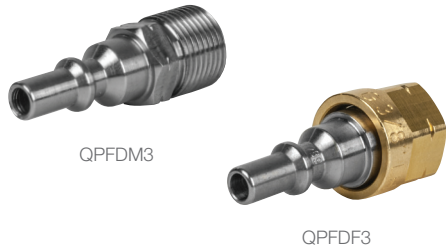

COUPLING PIN

Fuel Gas

Note: Threads are in accordance with EN 560 and ISO 3253

SPECIFICATIONS	QPFDM3	QPFDF3
Outlet connection	Pin G3/8" M	Pin G3/8" FM



GAS CONTROL

Part No: OTLDS

Gas Control is a technologically advanced gas leakage detection spray, designed to test the hermetic sealing of any type of gas system. The liquid has a special formulation to inhibit corrosion when used on copper, brass and steel. The liquid, when applied will detect the slightest leak, forming bubbles or foam where it occurs. A red nozzle can be fitted to the outlet for more directional control.

PART NO	DESCRIPTION
OTLDS	400g, UN 1950, aerosols, class 2.2

Flashbacks with Air-Propane Equipment

To have combustion, three elements are required: fuel, heat (ignition source) and oxygen. The Tesuco® range of air-propane equipment runs off cylinders of LPG only and is not to be used with compressed air or oxygen. As a result, the oxygen obtained by the equipment is drawn from atmosphere and therefore, fire is only possible where the three elements of combustion are available - that is, at the nozzle of the burners. Flashback arrestors are not required to be used on the air-propane equipment where compressed air or oxygen is not used, as flashbacks cannot occur.

Fitting of Flashback Arrestors

⚠ WARNING

Some worksites are requesting flashback arrestors to be fitted to the regulator outlet and the inlet of the torch handle. Given the information above in the "FLASHBACK" section stating flashbacks cannot occur in this equipment, we have decided to add information about the flashback arrestors which can be fitted so as these worksites can be covered.



Hazards and Precautions

Even though flashbacks cannot occur with air-propane equipment as detailed above, hazards still exist. Just 4% LPG in air is explosive and being heavier than air, can build up in pits or confined areas should there be any leaks or if unlit equipment is left on. All equipment should be checked prior to operation to ensure that there is no damage, fully leak tested with the appropriate leak detection spray Gas Control (OTLDS) before lighting and shut down according to the manufacturer's instructions.

Tesuco's range of Gas Stop equipment aides in ensuring that there are no leaks from the regulator to the handpiece, shutting of gas flow in the presence of the smallest of leak due to hose damage or loose connection between the regulator and hose or between the hose and the handpiece.

Details about the Gas Stop Anti-Leak System are on pages 11 and 12.



SOGS38

SOGSPOL

REGULATORS

The Gas Stop regulators have a special two stage design that only will allow gas to flow, once the outer hose of the system is pressurised. Any loss of pressure will shut off the gas supply from the regulator outlet. The "Gas Stop" is not an excess flow valve. The Gas Stop complies with the requirements list in EN16129.

Pressure regulators, automatic change-over devices, having a maximum regulated pressure of 4 bar, with a maximum capacity of 150 Kg/h, associated safety devices and adapters.

The Gas Stop safety device is in compliance with the EC Gas Appliances Directive EU/2016/426. Leakage and pressure regulations are according to DIN481.

These standards ensure the Gas-Stop anti-leak system is the safest on the market.

SPECIFICATIONS	SOGS38	SOGSPOL
Inlet connection	G3/8" LH FM	POL Type 21
Outlet connection	M22 x 1.5 LH M	M22 x 1.5 LH M
Max flow rate (kg/h)	7	7

Note: Large flow rates can be achieved by using a different model and hose system.

⚠ WARNING

Excess flow valve only shut-off when large flow are reach only. These excess flow valves DO NOT shut down and protect the system if small leak occur. Hose failure valve will only cut off the flow in the case of a hose rupture or the removal of the hose fitting to quickly.



SHP01-OM

SHP02-OM

TORCH HANDLE

The Gas Stop torch handles have the special inlet connection to suit the double Gas Stop hose and must be used as part of the Gas Stop system. These torch handles are ergonomically designed with a shock resistant grip which fits comfortably and securely into the hand. An integrated solid brass control valve and adjustment knob allows fine adjustment of the flame. Tesuco® also supplies an economiser torch handle with an independently adjustable pilot flame control valve. The economiser can also be set as a "deadmans" lever, to shut off the flow of gas to the burner. This feature saves both gas and work time, as gas consumption is reduced by up to 97% when the economiser valve is in use. The Flame Pro® torch handle fully complies with EN ISO 9012

SPECIFICATIONS	SHP01-OM	SHP02-OM
Type	Standard	Economiser
Inlet connection (mm)		M22 x 1.5
Outlet connection (mm)		M14 x 1
Operating Pressure (kPa)		150 - 400

Air-Propane

Gas Stop Anti-Leak Equipment

The Ultimate in Protection

FLAMEPRO

TESUCO
TECHNICAL SUPPLIES COMPANY



SOMGSH 6

HOSES

The hoses for the Gas Stop Integrated Anti-Leakage System have a unique hose in hose design. Any pressure difference between the two gas paths caused by loose connections or hose damage will cause the gas flow to be terminated at the regulator. They are available in different lengths.

Standards

Hoses - The hose in hose are made according to DIN4815-6. Hose material meets EN16436-1 international standards

SPECIFICATIONS	SOMGSH 2	SOMGSH 4	SOMGSH 6
Size (m)	2	4	6
Connection (mm)	22 x 1.5 LH FM		

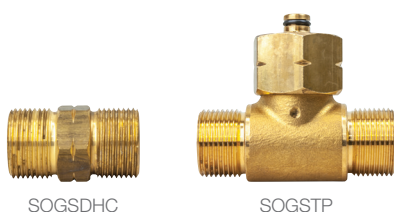

SOGSDHC

SOGSTP

CONNECTORS

These are used to join hoses, split supply to multiple applications and to connect equipment not originally designed for use with this system.

SOGSDHC joins two hoses together.

SOGSTP allows for an additional torch handle or appliance to be used.

Note: Connections to fit other equipment are available.

SPECIFICATIONS	SOGSDHC	SOGSTP
Description	Intermediate coupling	T-piece connection
Inlet connection (mm)	M22 x 1.5 LH M	M22 x 1.5 LH FM
Outlet connection (mm)	M22 x 1.5 LH M	M22 x 1.5 LH M

Function

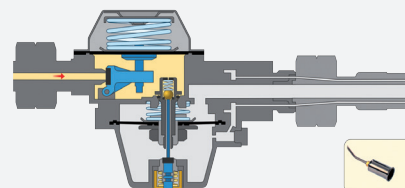

Open the cylinder valve. This allows the gas to flow to the valve seat.

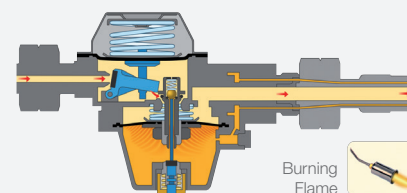

By pressing the filling knob, gas enters into the outer hose chamber and into the inner hose. The burner can be ignited.

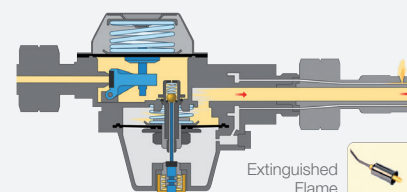

The Gas Stop will automatically stop the main gas supply from the cylinder if the hoses are cut in anyway, hose are burnt through or loose hose connections at either the regulator outlet or torch handle inlet.

Typical Application

Ultimate protection when working in confined spaces, underground or pits.



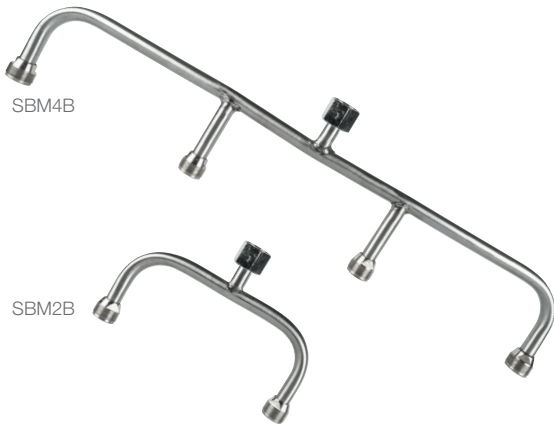

BURNER MANIFOLD

To Suit Broad Flame Burners

The burner manifolds are designed for use with the range of high capacity burners. When using these manifolds, it is important to ensure that the equipment being used, especially the regulator will provide sufficient gas flow.

SPECIFICATIONS	SBM2B	SBM4B
Number of burners	2	4
Inlet connection (mm)	M20 x 1 RH FM	
Outlet connection (mm)	M20 x 1 RH M	

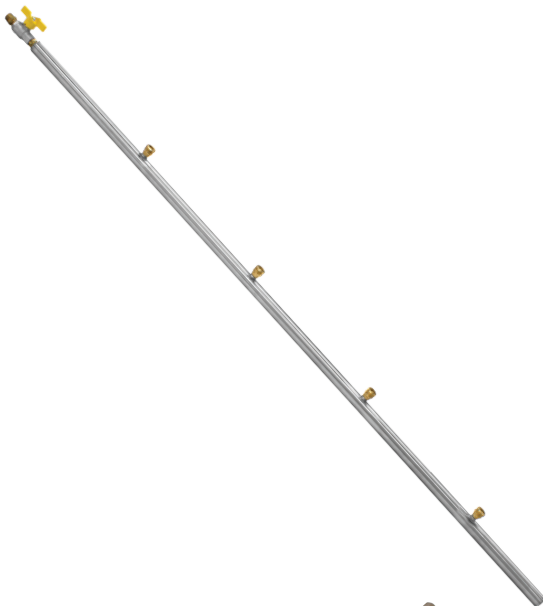

BURNER MANIFOLD

1,400 mm

Burner manifold is specially designed for heating a large area and suit the high capacity burners on page 7. Stainless steel arm is 1,400 mm in length and has a control valve at the inlet.

SPECIFICATIONS	SBM4B14
Number of burners	4
Inlet connection	G3/8" LH M
Outlet connection	M20 x 1 RH M
OD of barrel	25.5 mm
Distance between outlets	300 mm



BURNER TROLLEYS

To Suit Broad Flame Burners

Burner trolleys are designed for use with the range of high capacity burners. When using these trolleys, it is important to ensure that the equipment being used, especially the regulator will provide sufficient gas flow.

Torch handle economiser THP03 is designed to fit the inlet of the burner trolley.

Note: Trolleys are shown as a guide for manufacturing in your local area.

SPECIFICATIONS	SSBRA4	SSBRA6
Number of burners	4	6
Inlet connection	G3/8" LH M	
Outlet connection	M20 x 1 RH M	

Air-Propane Application Chart



	SNTBCF32	SNTBHS32	SSB30	SSB40	SSB50	SSB60	SSB80	SSB80-SPX	SNTBSB3	SNTBSB5	SNTBSB7	SNTBT12M	SNTBT18M	SNTBT22M	SNTBT28M	SNTB32P	SNTB64P
Adhesive removal	●			●	●	●	●	●								●	●
Aligning and bending work	●		●	●	●		●	●				●	●	●	●		
Aluminium soldering			●	●					●	●	●	●	●	●			
Annealing			●	●	●	●	●	●				●	●	●	●		
Annealing copper tubes												●	●	●	●		
Asphalt work					●	●	●	●									
Bending heavy tubes	●		●	●	●	●	●	●					●	●	●		
Bending lighter tubes	●	●	●	●								●	●				
Capillary brazing									●	●	●						
Capillary soldering									●	●	●	●	●	●	●		
Ceramic tile removal	●			●	●	●	●	●								●	●
Cooling and refrigeration work	●				●												
Copper bit soldering			●						●	●	●	●	●				
Enamelling			●	●	●	●											
Floor work	●			●	●	●	●	●								●	●
Forging work			●	●		●											
Foundry work			●	●	●	●	●	●									
Glazing work	●		●	●	●	●											
Hardening work	●		●	●	●	●						●					
Heat shrinking materials	●	●	●	●	●	●	●	●									
Heating polyolefin heat shrink	●	●															
Bending plastic tube, etc.		●	●	●	●	●						●	●	●			
Heating vessels/containers	●	●		●	●	●						●	●	●	●		
Hobby work	●		●	●	●	●			●	●	●					●	●
Insulating work	●	●	●	●	●	●								●	●		
Laboratory work	●		●	●													
Large brazing					●	●	●	●									
Large soft soldering	●		●	●								●	●	●	●		
Melting metal	●			●	●	●	●	●							●		
Melting of compounds	●			●	●	●	●	●						●	●		
Paint stripping		●		●	●	●											
Pre-heating prior to welding			●	●	●	●	●	●				●	●	●	●		
Precision work									●	●	●						
Road work					●	●	●	●									
Roofing work				●	●	●	●	●						●	●		
Sheet metal work			●	●	●							●	●	●	●		
Ski waxing																●	●
Small brazing				●								●	●				
Small soft soldering			●						●	●	●	●	●				
Soldering heavy duty			●	●										●	●		
Stress relieving			●	●	●	●						●	●	●	●		
Tempering work	●		●	●	●	●						●	●	●	●		
Thawing work		●		●	●	●						●	●	●	●		
Ventilation work		●		●	●	●											
Weed burning		●			●	●											

Note: Flame pressure was set 150 kPa for all photos.

Pin-Point Burner

This efficient, soft sweeping, windproof flame with a pronounced yellow tip is visible when working in daylight. Applications include medium and heavy walled insulated tubing for electrical and telecommunication, cable termination systems and busbar tubing.

Burner Size: SNTBSB5



Cyclone Burner

Produce a cyclone rotating vortex flame to enable target heat to be applied to the working surface. They are ideally suited for pipe soldering, soft soldering and brazing, bending tubes, small forging, thawing frozen pipes, annealing and tempering.

Burner Size: SNTBT18M



Soft Flame Burner

The compound flame burner design is ideal for melting metals, glazing work, hobby work, adhesive removal and other applications.

Burner Size: SNTBCF32



Standard Flame

Highly effective full bodied windproof flames, suitable for those applications requiring high manageable heat output to a large surface area. They are ideal for preheating steels prior to welding, flooring, roofing and asphalt work, ceramic tile removal and automotive applications.

Burner Size: SSB50

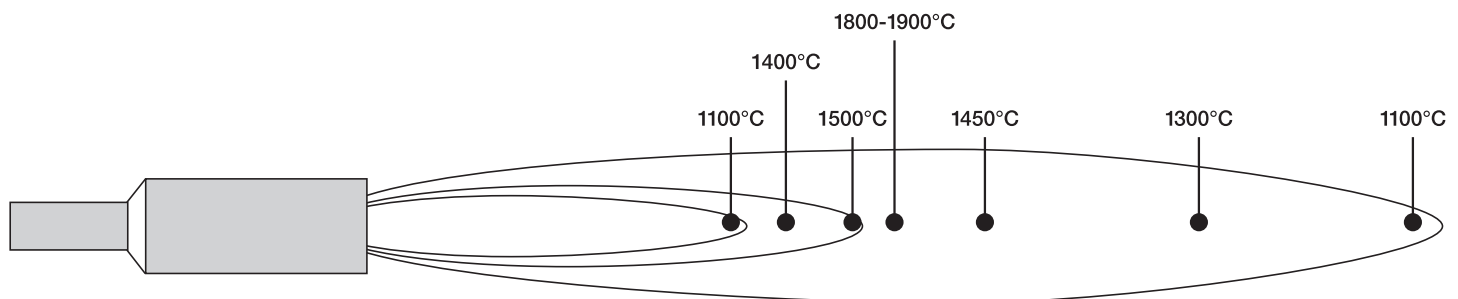

Flame Burning Temperature

The maximum flame burning temperature is approximately 1925°C (diagram above states 1900°C). All burners reach the same temperature however large burners will generate more heat due to the flame area, for example: A 60 mm burner compared to a 30 mm.

The above highlights the different temperatures within the flame.

Air-Propane Specifications



Safe Checks

When choosing the correct setup required for the application, ensure the propane supply is adequate to meet the demands of short or long term use. Long term use may require larger cylinders or small cylinders to be manifolded together. Always check the equipment for leaks before lighting the burner. Always, once the system is connected, adjust the torch handle valve fully to the “-” position (Off), Turn on the cylinder valve. With the system pressurised, check the connections with “Gas Control” leakage detection spray (See page 12 for Gas Control, part no: OTLDS). No bubbles should be seen if the system is free of leaks. If bubbles appear, do not use the system until the leak has been eliminated. Always use a flint lighter to light the burner. Check the hose regularly for cracks in the rubber and replace if found, do not repair the hose. Hoses which are exposed to outdoor sunlight will age quicker. When not in use, always depressurise the system. Turn off the cylinder and open the torch handle valve towards the “+” symbol (ON), releasing the pressure in the system.

Storage

The cylinder/s can be stored for a long time without any effect on the propane. Always disconnect any equipment. Store the cylinder and equipment in a safe well-ventilated area away from any heat source. Follow all local requirements on the storage of cylinders.

Cylinder Delivery

The cylinder size will effect then amount of gas withdraw based on the liquid inside the cylinder and the outside temperature. Cooler cylinders will reduce the pressure in the cylinder. Flame Pro® high capacity burners need a high supply of gas to ensure the maximum flame setting can be achieved. When using a manifold burner with 2 or 4 burners attached, you may need to use a bulk supply system or join multiple 45 kg cylinders together to gain the flow rate from the cylinder based on the burner size. The following table guide shows the flow rate of common cylinder sizes in our market. This indicates the flow of gas over a continuous use during a one hour period with the air temperature and the cylinder size.

TEMPERATURE	+20°C	0°C
Full 45 kg Propane	15.5 kg	6.5 kg
Full 18 kg Propane	6.2 kg	2.6 kg
Full 9 kg Propane	3.1 kg	1.3 kg

Figures are a guide only

Flame Temperature

Air-Propane has a maximum temperature of around 1925°C, for the ease of our tables, we state 1900°C.

Depending on the size of the object (length and thickness) this temperature may not be achieved due to heat dispersement, transfer and the time taken to heat the object. Your choice of burner/s and cylinder size is important to reach the temperature required.

LPG & Technical Specifications

PROPANE	
Chemical formula	C ₃ H ₈
Density @ 15°C	Heavier than air
As Gas	1.85 kg/m ³
As Liquid	0.51 kg/l
Boiling point @ atmospheric pressure	-42°C
Gas pressure @ -20°C	1.5 bar
Gas pressure @ 0°C	4 bar
Gas pressure @ +20°C	7.5 bar
Energy content	50.4 MJ/kg 12.8 kWh/kg
Amount of air required for combustion	12.2 m ³ /kg
Maximum flame temperature with air	1925°C
Combustion mixtures, volume - % gas in air	2.1 - 9.5%

Melting Points of Soldering Metals

SOLDERING METAL	TEMPERATURE
Tin solder	190 - 280°C
Aluminum soft solder	380°C
Aluminum hard solder	580°C
Silver solder	610°C
Phosphor copper solder	720°C
Bronze solder	860°C

Melting Points of Metals

METAL	TEMPERATURE
Lead	327°C
Zinc	419°C
Aluminum	658°C
Silver	961°C
Gold	1063°C
Copper	1084°C

Registered Trademarks

Tesuco®

Bevline®

Leakxpose®

Flame///Pro®

Flame Pro™

FLAME  **PRO**

TESUCO TECHNICAL SUPPLIES COMPANY	HOSPITALITY
	GAS SAFETY
	INDUSTRIAL
	SCIENTIFIC
	MEDICAL

PHONE **+61 2 9737 9937**
EMAIL **sales@tesuco.com.au**
WEB **www.tesuco.com.au**

The information in this brochure is to be used as a guide only.
The ultimate responsibility for safe use of the equipment lies with the operator. In the interest of constant improvement in quality and design, product specifications may change at any time, without notice. E&OE

DISTRIBUTED BY

