

Generator set
Sound-proof type
GMS200CS-AU

SPECIFICATIONS

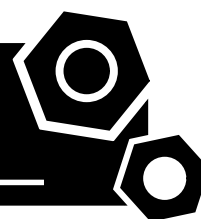

1 Standards & Conditions

Design Standards

The designs and the productions are in conformity with:

- Conformance European (CE)
- China Compulsory Certification (CCC)
- ISO8528-5:2005
- GB/T2820.5-2009
- AS 3000-2018
- AS 3010.1-2017

Environmental Operating Conditions

- Installation place: Outdoors or indoors (well ventilated).
- Ambient temperature: -25°C to 45°C. The coolant heater is needed when the temperature is below 5°C
- Humidity: Less than 90%.
- Altitude: Below one thousand (1000) meters above sea level.

Factory Inspection

- Inspection items.
- Protection devices working test.
- Starting ability in normal temperature.
- 50% rated power load moment capability.
- Voltage deviation and speed variation: 0%, 25%, 50%, 75%, 100%, 110% Load.

Painting Process

- Painting process specifications and colors are based on the manufacturer's standard.
- The customer could also choose the color which the manufacturer offers.

2 General Features

- Cummins engine 6CTAA8.3-G2
- Close coupled to a Stamford alternator UCI274H
- Microprocessor control module PLC-7420
- ABB main circuit breaker: 320A
- Rotate speed governor: Electrical governor S6700E
- Excitation System: PMG
- A.V.R. Model: MX341
- Key switch
- Emergency stop switch
- ATS (automatic transfer switch) receptacle

- Remote run connector
- 2x12V/120AH sealed for life maintenance free battery
- Lockable battery isolator switch
- Powder coated canopy
- 50°C radiator
- Oil pump on the engine
- Non-returning valve for fuel inlet hose of the engine
- Steel base frame with forklifts
- Vibration isolators between the engine/alternator and base frame
- Dry type air filter
- Base fuel tank for 24 hours running
- Drain points for fuel tank
- Breather valve for fuel tank
- Operation Manual / Specifications

3 Equipment Specification

General technical data

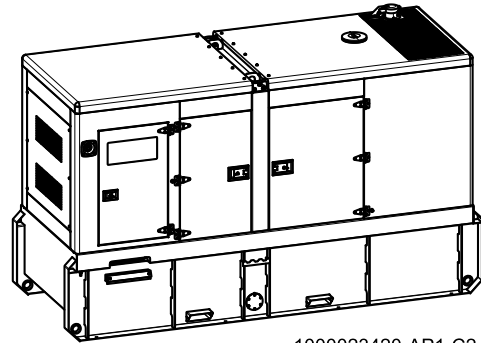

1000023420-AP1-C2

Model.....	GMS200CS-AU
Structure type	R
Tank capacity.....	1330L
Dry weight.....	2959kg
Sound pressure level @ 1m/7m	85.98(A)/76.48dB(A)
Sound power acc. 2000/14/EC.....	104.37dB(A)
Dimensions L×W×H.....	3592x1322x2152mm
Standby Power	220kVA/176kW
Prime Power	200kVA/160kW
Voltage/Ampere.....	415V/278A

Genset Fuel Consumption					
Frequency/Load	25%	50%	75%	100%	110%
50Hz (L/h)	13.5	23.3	34.0	45.4	51.4

Diesel Engine

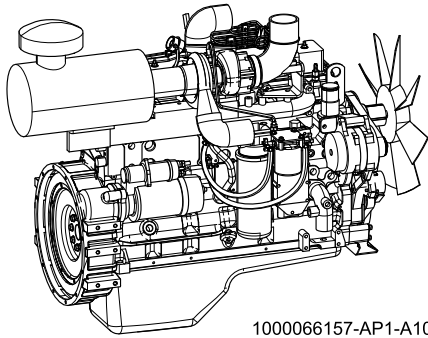

1000066157-AP1-A10

Engine Manufacturer/Brand.....	Cummins
Engine Model.....	6CTAA8.3G2
Dimensions L×W×H.....	1485.3*866.5*1245.0
Dry Weigh (approx.)	702kg
Number of Cylinders.....	6
Bore.....	114mm
Stroke.....	135mm
Displacement.....	8.3L
Compression Ratio.....	N/A
Type of injection.....	Direct injection
Intake System.....	Turbocharged,water-to-air charge cooled
Intake Resistance.....	≤6.28kPa
Cooling System	Water cooled
Fan	Pusher
Battery Voltage	12/24V
Type of Fuel.....	Diesel
Type of Oil	ACEA E2, API CF, CF-4, CG-4
Oil Capacity	18.9L
Type of Coolant	Glycol mixture
Coolant Capacity	45.3L
Back Pressure	≤10.1kPa
Heat Rejected To Exhaust System... 123kW(6999BTU/min)	
Heat Rejected To Water&Lube Oil..... 83kW(4723BTU/min)	
Standby Power	203kW
Prime Power	183kW
Fuel Consumption(100%load).....	45.4L/h

Alternator

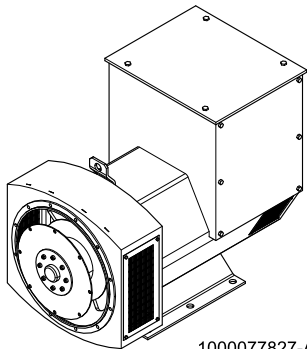

1000077827-AP1-A1

Alternator Manufacturer/Brand	Stamford
Alternator Model	UCI274H
Exciter.....	Brushless
Cooling Fan	Cast alloy aluminum
Windings.....	100% copper
Insulation Class	H
Winding Pitch.....	2/3
Terminals	12
Drip Proof	IP23
Altitude.....	≤1000m
Overspeed	2250rpm
Air Flow.....	0.514m³/s(50Hz),0.617m³/s(60Hz)
Voltage Regulation	±1.0%
Total Harmonic TGH / THCat no load < 1.5 % - on load < 5%	
Telephone Interference.....	THF<2%;TIF<50

PLC-7420 Control System

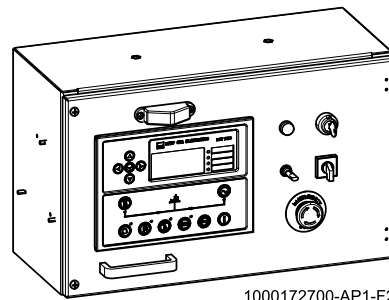

1000172700-AP1-F2

PLC-7420 is an advanced control module based on micro-processor, containing all necessary functions for protection of the genset and the breaker control. It can monitor the mains supply, and automatically start the engine when the mains is abnormal. Accurately measure various operational parameters and display all values and alarms information on the LCD. In addition, the control module can automatically shut down the engine and indicate the engine failure.

- Microprocessor control, with high stability and credibility
- Monitoring and measuring operational parameters of the mains supply and genset
- Indicating operation status, fault conditions, all parameters and alarms
- Multiple protections; multiple parameters display, like pressure, temp. etc.
- Manual, automatic and remote work mode selectable
- Real time clock for time and date display, overall runtime display, 250 log entries
- Overall power output display
- Integral speed/frequency detecting, telling status of start, rated operation, overspeed etc.
- Communication with PC via RS485 OR RS232 interface, using MODBUS protocol

4 Overall Dimensions

1000023420-DR1-C2

Dry weight	2959kg
Fuel tank capacity	1330L
Dimensions L x W x H	3592x1322x2152mm

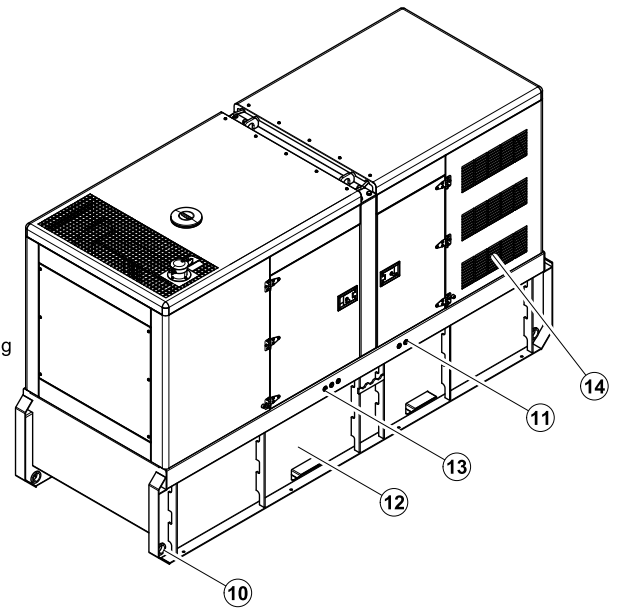
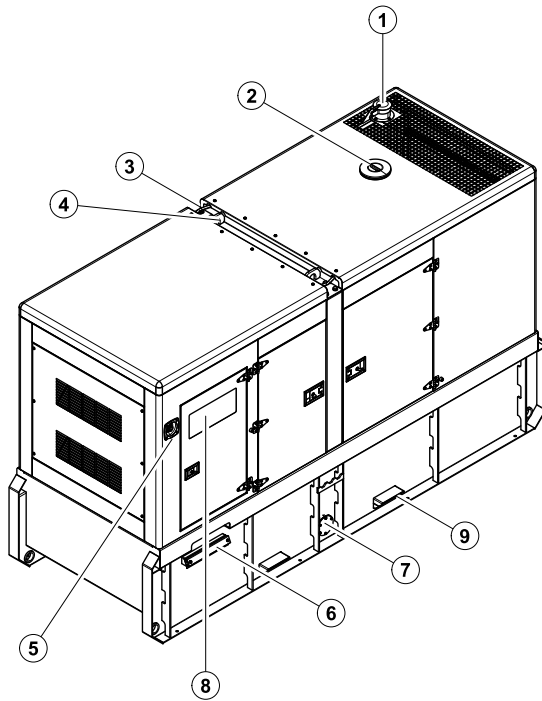

- | | |
|-------------------------|---|
| ⑦ Fuel drain | ⑭ Air inlet |
| ⑥ Cable trench | ⑬ Coolant drain/
External fuel inlet/return hose fitting |
| ⑤ Emergency stop switch | ⑫ Base frame |
| ④ Lifting lug | ⑪ Oil drain hose fitting |
| ③ Roping lug | ⑩ Tie down |
| ② Coolant inlet | ⑨ Fork lift channel |
| ① Exhaust gas outlet | ⑧ Control cabinet |

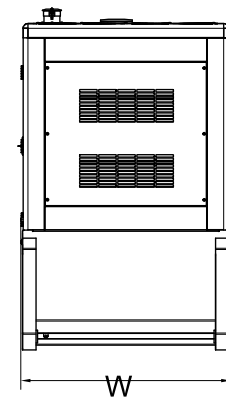
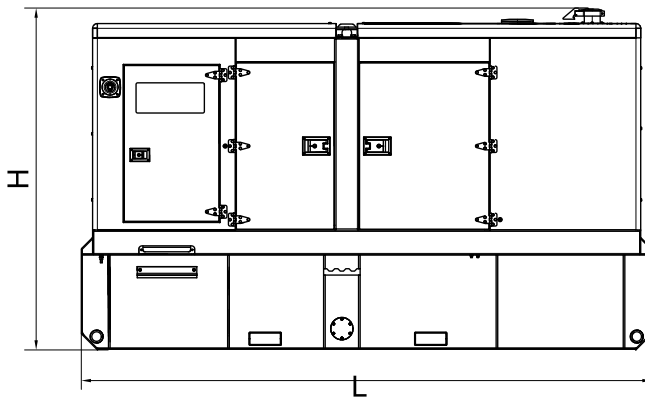

5 Control System

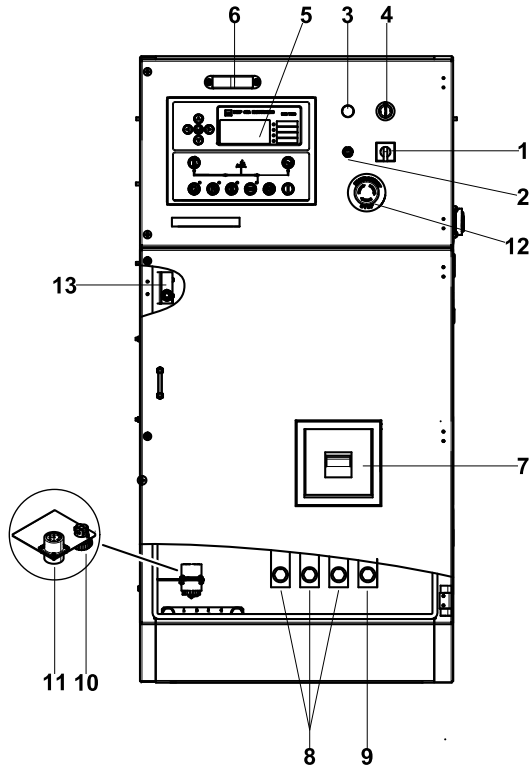

Control & Field wiring cabinet

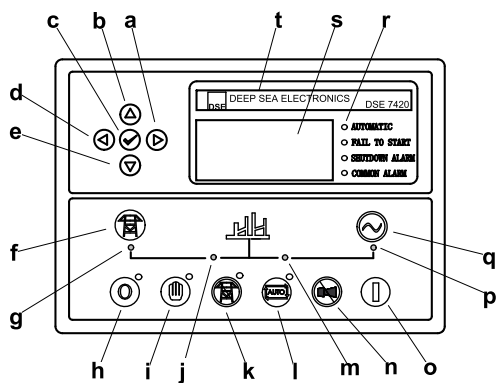

Control module

Ref.	Description
1	Mains input changeover switch
2	Control cabinet lamp switch
3	Charge indicator
4	Key switch
5	Control module
6	Control cabinet lamp
7	Main circuit breaker
8	Live wire terminals
9	Neutral wire terminal
10	Mains input/Remote control communication connector
11	Mains input/Remote control/ATS communication connector
12	Emergency stop switch
13	Limit switch

a	Button (next page)
b	Button (increase value / previous item)
c	Button (accept)
d	Button (previous page)
e	Button (decrease value / next item)
f	Button (transfer the load to the mains supply, when in Manual mode only)
g	Mains supply available LED
h	Stop / Reset button
i	Manual button (Manual control mode)
j	Mains supply on load LED
k	Test button (Test mode)
l	Auto button (Auto mode)
m	Genset on load LED
n	Mute/Lamp test button
o	Start button (Manual)
p	Genset available LED
q	Button (transfer the load to the genset, when in Manual mode only)
r	Alarm LED (4 alarm items)
s	LCD display
t	Control module name

6 Derate Curves

GENERATOR SET DERATE CURVES (GMS200CS-AU)

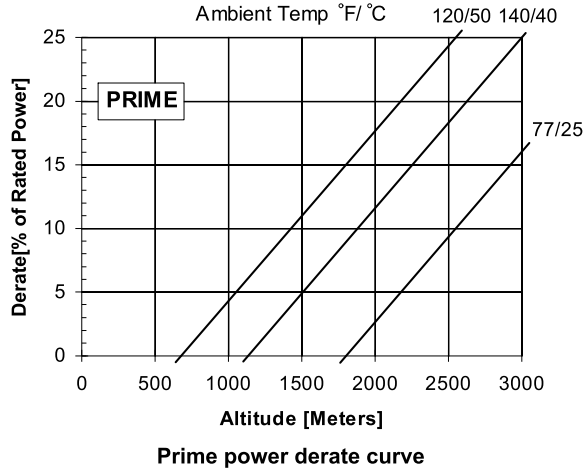

ENGINE DERATE CURVES @ 1500RPM (6CTAA8.3G2)

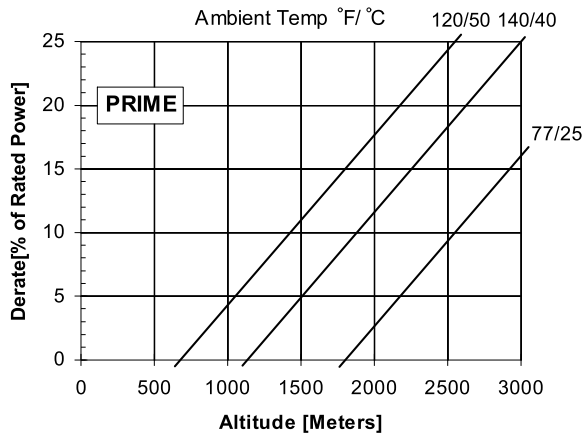

ALTERNATOR DERATE CURVES (UCI274H)

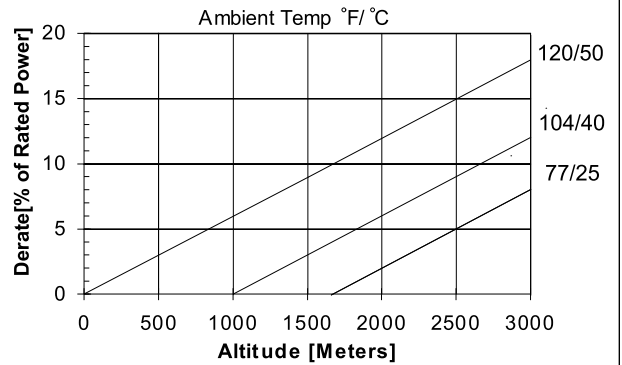

1000023420-C2-E

06.2019

<http://www.powerlinkworld.com>

*Specification may change without prior notice. For more info.,
contact Power Link or your local distributors please.*