

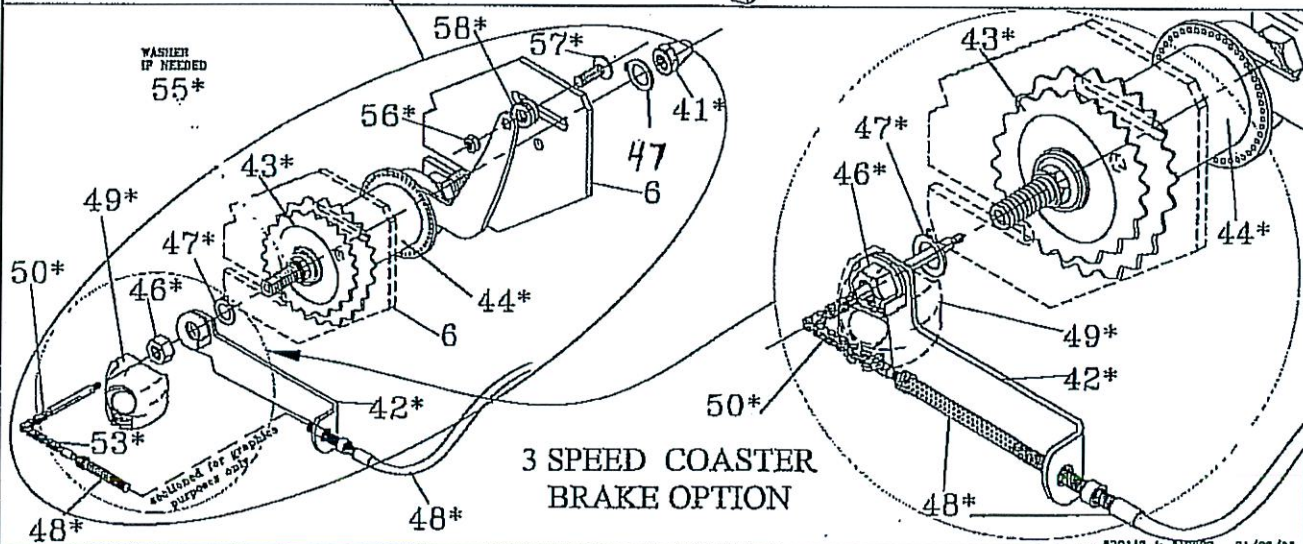

Trailmate

24" & 26" HEFTY HAULER

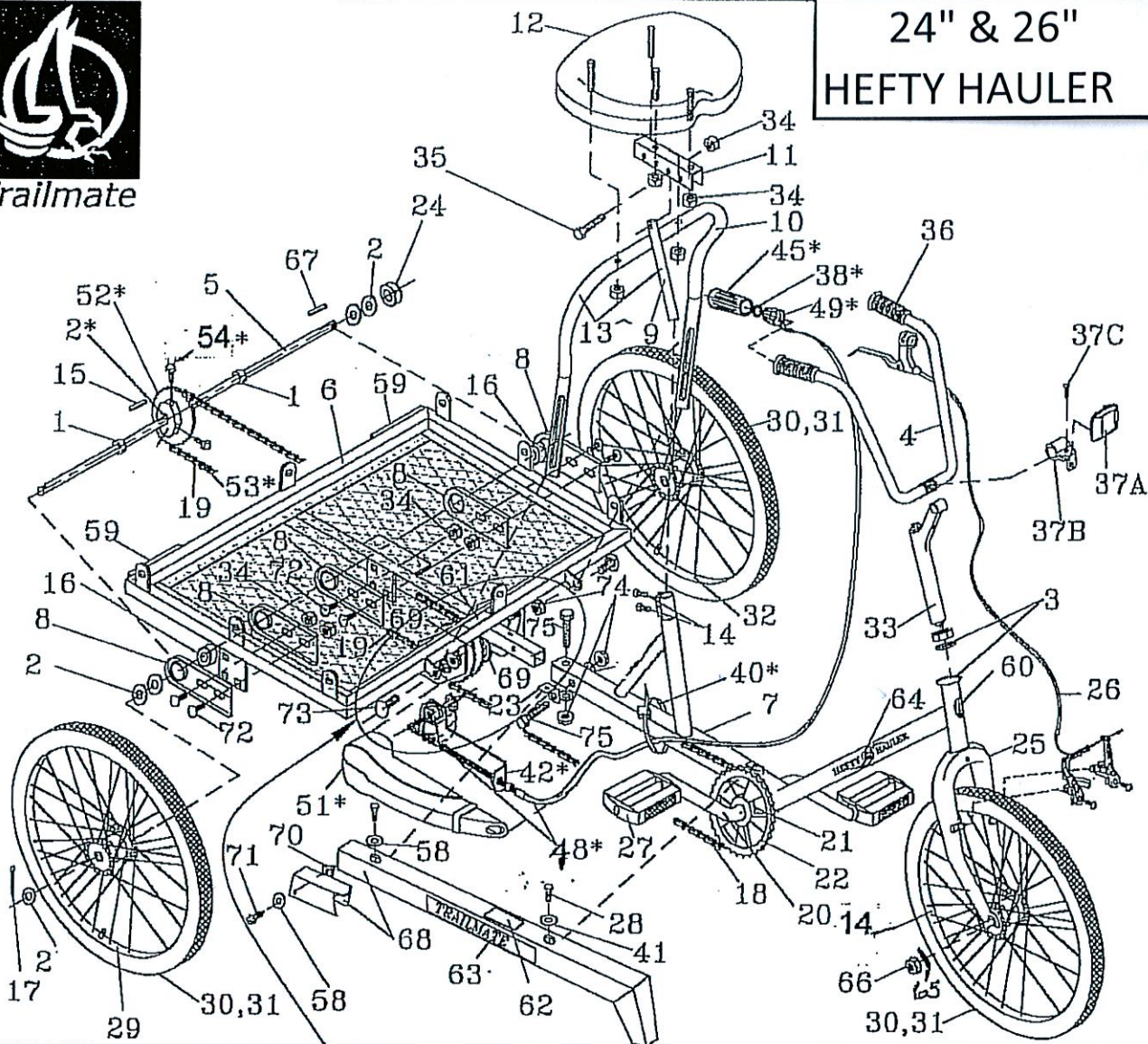

INDUSTRIAL 24" 26" HEFTY HAULER (HH) PARTS LIST

<u>ITEM#</u>	<u>PART #</u>	<u>DESCRIPTION</u>	<u>QTY</u>	<u>ITEM#</u>	<u>PART #</u>	<u>DESCRIPTION</u>	<u>QTY</u>
1	12241	SET COLLAR 5/8	2	37A	11861	REFLECTOR CLEAR FRONT	1
2	19640	WASHER 5/8 SAE	4	37B	11865	BRACKET FRT REFLECT	1
3	11831	HEAD SET COMPLETE	1	37C	20379	SCREW FOR 11865 FRT REF BRKT	1
4	11805	HANDLEBAR HI RISE	1			3 SPEED COASTER BRAKE OPTION *	
5	20144	AXLE 24/26" INDUST REAR 37"	1	38*	19713	3SPCB/5SPD PLASTIC WASHER	1
6	19727BLK	FRAME IND REAR ASSY BLACK	1	39*	12240	WASHER SPACER 1X41/64X.062	6
7	20143	FRAME HH 24/26" FRONT	1	40*	12269	TIE CABLE BLACK 8 X .18	4
8	18220BLK	AXLE BEARING HOLDER BLK	5	41*	18985	3SPCB FWL - DOME NUT	1
9	20245BLK	SEAT POST 15"X1' OD BLK	1	42*	20141	3SPCB FWL - FULCRUM LEVER	1
10	12075	SISSY BAR	1	43*	18909	3SPCB FWL - 21T SPROCKET	1
11	11898	BRACKET WESTERN SADDLE	1	44*	18875	3SPCB HUB TRIKE W/ 22T SPKT	1
12	11894	SEAT WESTERN SADDLE	1	45*	19710	GRIP BLACK 3SPCB #HG5718	1
13*	20247	EXT. SEAT POST/SISSY BAR(OPT)	1	46*	18049	3SPCB FWL - AXLE NUT R.H.	1
14	12032	WHEEL FRONT 26X2.125X.105	1	47*	18986	3SPCB FWL - LOCK WASHER	2
	20227	WHEEL FRONT 24X1.75X.105	1	48*	20163	3SPCB SHIFTER-W/CABLE-IND	1
15	12246	KEY SQUARE 3/16X58"	1	49*	20140	3SPCB GEAR SELECTOR GUIDE	1
16	11643	BEARNING AXLE	5	50*	18997	3SPCB INDICATOR ROD & CHAIN	1
17	11139	PIN COTTER 1/8X1	1	51*	20306	3SPCB INDICATOR COVER	1
18	20168	CHAIN 24/26" IND. LONG 121 P.	1	52*	11952	SPROCKET 22T SOLID W/ADAPTER	1
19	20309	CHAIN IND SHORT 67 PITCH	1	53*	20309	CHAIN/CL IND 24/26" SHT 67 PIT	1
20	11696	CRANK 6 1/2 26" IND.	1	54*	11071	SET SCREW 5/16-18X3/8W/PATCH	2
21	11697	CRANK BEARING SET COMPLETE	1	55*	12301	WASHER 3/8 FLAT SAE	4
22	11934	SPROCKET 36T 1/2 X 1/8	1	56*	12170	NUT 10-32/STAR	1
23	20148	CHAINGUARD BRACKET HH	1	57*	12193	SCREW 10-32X1 PHIL PAN HD M/S	1
24	19720	NUT 5/8 - 18 NYLON INSERT	1	58*	12229	WASHER #10 FLAT	3
25	19403	FORK 26"MWT CANTILEVE	1	59	17380	REFL R RED STICK ON 20-0004-01	2
	19337	FORK 24"MWT CANTILEVER	1	60	11718	DECAL TM HEAD	1
26	18227	BRAKE CABLE 34X42	1	61	19325	DECAL "DO NOT STAND ON CYCLE"	1
27	11857	PEDAL 1/2" PR (COMPLETE PAIR)	1	62	14089	DECAL AVOID SHARP TURNS	1
28	12188	SCREW 10-32X3/8 SLTD HWH	2	63	11719	DECAL AVOID SHARP TURNS	1
29	20151	WHL 26X2.125 SPOKE ZINC	1	64	20118	DECAL HEFTY HAULER	1
	20248	WHL 24 X 2.25 SPOKE ZINC	1	65	12235	WASHER 5/16 USS	2
30	11985	RIMSTRIP 24X1.75	3	66		NUT 3/8-26	2
31	20156	TIRE 26X2.125 W/TUBE K28	3	67	20012	KEY SQ 3/16 X 1-1/4	1
	19590	TIRE 24 X 2.125 BSW/TUBE K52A	3	68	20145	CHAINGUARD 24/26" HH	1
32	20152	WHL 26X2.125 IND 4.25"HUB DRV	1	69	20001	HANDLEBAR JUNIOR JR RIGHT	1
	20268	WHL 24 X 2.25 IND 4.25"HUB DRV	1	70	12170	NUT 10-32/STAR	1
33	11815	STEM 12"	1	71	20281	SCREW 10-32X3/8 PHL PAN HD M/	1
34	12175	NUT 5/16-18 FLANGED	7	72	12215	SCREW 5/16-18X3/4 CARRIAGE	6
35	12212	SCREW 5/16-18X1-1/2 HHCS GR 5	1	73	12218	SCREW 3/8-16X3/4 SHT NECK CARI	2
36	11801	GRIP BLACK DC 7/8	2	74	12178	NUT 3/8-16 FLANGED	4
				75	16590	SCREW 3/8-16X2-1/2 HHCS GR5	2

INSTRUCTIONS 24" & 26" HEFTY HAULER

1. Remove back (6) and front (7) frame assemblies from carton.
2. Slide back frame assembly (6) in to front frame assembly (7) fasten securely using bolts (75) and nuts (74).
3. (Rear View) Remove, the outside cotter pin (17) and washer (2), from right axle, install wheel with bearing (29) and fix in place with cotter pin and washer.
4. (Rear View) Install left wheel (32) on axle, using washer (2), key (67), and nut (24)
5. Install the long chain (18) on front sprocket (22).
6. Install chain guard (68).
7. Install handlebar assembly (4).
8. Fasten seat (12) and sissy bar (10) on frame
9. Install pedals (27).
10. Adjust seat and tighten securely by screw (35) and nut (34).
11. Fasten cable to frame with tie cables (40).

Option Front Basket.

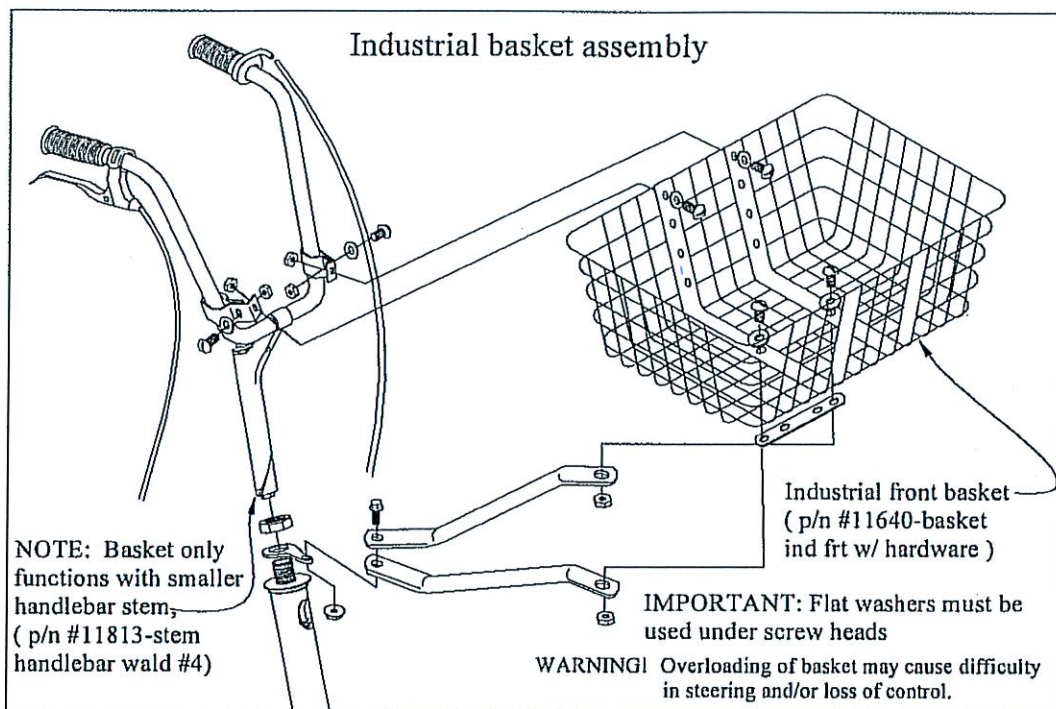

Industrial Hauler

*This is a recreational unit, not designed for excessive speeds or misuse.
Careless operation may cause ride to lose control and result in serious injury.
Do not brake or turn at high speeds; this may cause to roll-over and rider injury.*

Things to know before riding you cycle:

1. Know your local bicycle laws and wear a helmet.
2. Do not exceed the recommended weight limit 500 lbs.
3. Do not stand on unit.
4. Wear light-colored clothing.
5. Do not ride at night.

MAINTENANCE AND INSPECTION

REGULAR MAINTENANCE: Bi-Monthly

1. Keep all painted parts cleaned and waxed for along-lasting luster.
2. Lubricate the following:
 - Axle shafts
 - Chain- turn pedal crank forward and spray freely.
3. When storing over prolonged periods, turn upside down to prevent flats from occurring on the tires. If stored outside, cover to protect finish and moving parts.

PREVENTIVE MAINTENANCE: Every Six Months

These are services that should be performed by you local bicycle shop. A fee may be charged.

1. Check tires for wear, rim cuts and valve core alignment (usually caused by improper air pressure)
2. Check wheels for cracks and alignment.
3. Check brakes for proper operation.
4. Check and repack all bearings and adjust all cones.
5. Check for worn bearings, cones and cups.
6. Check chain for adjustment and clean as needed.
7. Check for loose bolts and nuts.

Attention: While your unit is new, some noises may occur when the unit is breaking in. Should they continue for more than 30 days, see local bike shop.

INSPECTION

Check the following, as it applies to your cycle, on a regular basis:

1. Hand Brake: Make sure the brake engages, by squeezing the hand brake.
2. Wheels: Check wheels for alignment.
3. Pedals: Inspect pedals and make sure pedals is tightly attached to crank.
4. Handle grips: Replace worn or loose grips.
5. Chain: Check for proper tightness. Replace damaged chain immediately.
6. Seat: Adjust seat for ride comfort and safety.
7. Tires: Keep tires inflated to the recommended tire pressure, as indicated on the tire's sidewall.
8. Frame: Replace damaged frame immediately.



Trailmate

1851 67th AVE East

Sarasota, FL 34243

Tel: (941) 755-5511

Fax: (941) 758-5141

Visit us @ www.trailmate.com

**For service or to order
replacement parts
please contact your
local Trailmate dealer.**

INDUSTRIAL HEFTY HAULER

This is a recreational unit, not designed for excessive speeds or misuse.

Do not brake or turn at high speeds. This may cause cycle to roll over. Careless operation may cause rider to lose control and result in serious injury.

Things to know before riding your cycle:

1. Know your local bicycle laws and wear a helmet.
2. Do not exceed the recommended weight limit of 500 lbs.
3. No more than one rider at one time.
4. Do not stand on unit.
5. Be sure to install safety flags.
6. Wear light-colored clothing and protective gear.
7. Do not ride at night.
8. Children must be supervised by an adult at all times.

Trailmate Limited Warranty

Trailmate, Inc., guarantees each cycle product against all defects in materials and workmanship for a period of 90 days from date of purchase. Tires and tubes are not covered by this guarantee.

During this period, any part that is judged by the makers to be defective will be replaced free of charge. Any failure resulting from accident, abuse, neglect, normal wear, or improper assembly or maintenance by the owner is not covered.

Trailmate, Inc., further authorizes a lifetime frame guarantee and will replace any frame, at no cost to the buyer, providing that item has not been used for rental use and that:

- 1) The item has not been altered, repaired, or modified in any way.
- 2) The item has not been subject to misuse, negligence, and/or an accident.
- 3) Original ownership is established.

Any parts under this guarantee on which claims are entered shall be returned for inspection with transportation charges prepaid by the claimant. Replacement parts will be shipped F.O.B. factory.

There are no warranties or guarantee, expressed or implied, written or oral, which extend beyond the description on the face hereof.