

apuro

Rice Cooker

Instruction manual



Model:

J300-A / CK698-A / CB944-A / CN324-A

Safety Tips

- Position on a flat, stable surface.
- A service agent/qualified technician should carry out installation and any repairs if required. Do not remove any components on this product.
- Consult Local and National Standards to comply with the following:
 - Health and Safety at Work Legislation
 - Fire Precautions
 - Wiring Regulations
 - Building Regulations
- DO NOT immerse the appliance in water.
- Do not touch hot surfaces with bare hands. Always use protective gloves.
- Use extreme caution when moving or handling appliances containing hot oil or any other hot liquid.
- Never fill the inner bowl above the top water line.
- Never allow water or any liquid into the outer pot.
- Only use utensils provided with this appliance when using the rice cooker. Sharp objects may damage the non-stick coating of the inner bowl.
- Do not use the appliance for anything other than its intended use.
- Do not plug in the cable until ready to cook. The rice cooker's power will remain ON unless unplugged.
- Always switch off and disconnect the power supply to the appliance when not in use.
- Not suitable for outdoor use.
- Keep all packaging away from children. Dispose of the packaging in accordance to the regulations of local authorities.
- If the power cord is damaged, it must be replaced by an Apuro agent or a recommended qualified technician in order to avoid a hazard.
- Children should be supervised to ensure that they do not play with the appliance.



- This appliance is not intended for use by persons (including children) with reduced physical, sensory or mental capabilities, or lack of experience or knowledge, unless they have been given supervision or instruction concerning the use of the appliance by a person responsible for their safety.
- Apuro recommend that this appliance should be periodically tested (at least annually) by a Competent Person. Testing should include, but not be limited to: Visual Inspection, Polarity Test, Earth Continuity, Insulation Continuity and Functional Testing.

Introduction

Please take a few moments to carefully read through this manual. Correct maintenance and operation of this machine will provide the best possible performance from your Apuro product.

Pack Contents

The following is included:

- Apuro Rice cooker
- Measuring cup
CN324-A/CB944-A x 1
J300-A/CK698-A x 2
- Spoon
- Fork (J300-A/CK698-A)
- Instruction manual
- Silicone mat (CK698-A only)

Apuro prides itself on quality and service, ensuring that at the time of packaging the contents are supplied fully functional and free of damage.

Should you find any damage as a result of transit, please contact your Apuro dealer immediately.

Operation

Cooking Tips

Wash the rice thoroughly before cooking. This helps to stop rice grains sticking together.

- A small amount of vegetable oil in the rice can help separate grains.
- Brown or wild rice may require additional water.

Using the Rice Cooker

The inner bowl features measurement lines inside as a guide. The cup provided is designed to measure the rice and water.

1. Measure the desired amount of rice using the measuring cup supplied.

Note: One cup of rice will produce approximately two cups of cooked rice.

2. Rinse the rice in a sieve under running water to remove excess bran and starch.

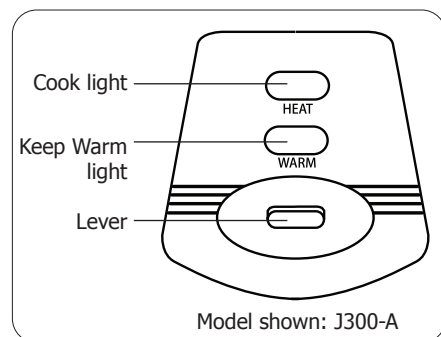

3. Pour the rice into the inner bowl. To achieve evenly cooked rice, spread evenly around the bowl.
4. Add the correct amount of water by using the measuring cup, or by filling the inner bowl to the appropriate level.



Note: Slightly reduce the amount of water for firmer rice, and increase the amount for softer rice.

5. Place the inner bowl into the rice cooker.

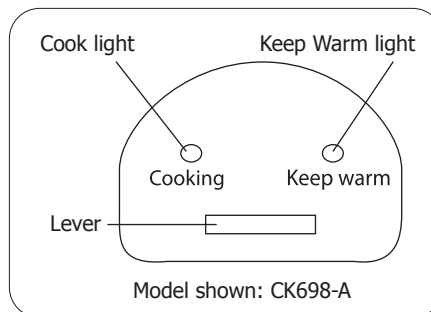

Note: Ensure there is no rice or moisture on the outside of the inner bowl.

6. Replace the lid (CN324-A/CB944-A) or close the lid and press down until the latch snaps shut (J300-A/CK698-A).
7. Connect the rice cooker to the power.
8. Depress the lever to the COOK position. The Cook light turns on.
9. Once cooking is finished the switch automatically moves to the WARM position. The Warm light turns on.
10. Keep the lid closed for 10 - 15 minutes for best results.
11. Carefully open the lid, allowing any steam condensation to run back into the rice cooker.



WARNING: Always take care to avoid the expulsion of steam when removing the lid.

Always use heat proof gloves when removing the inner bowl after cooking.

12. Stir the rice and serve as quickly as possible.
13. Disconnect the appliance from the power supply.

Rice/Water Measurements

- As a general guide, use one full cup of water to each full cup of rice.
- Add slightly more water for softer rice, or slightly less water for firmer rice.

For CK698-A only:

- The inner bowl contains a guide for cooking washed white rice. E.g. to cook 10 cups of washed white rice add 10 x 430ml cups of rice to inner bowl then fill water to waterline (you may need to vary the amount of water to achieve results to your liking).
- Brown or wild rice may require additional water.

Raw White Rice (430ml cups)	Waterline inside Pot	Approximate Servings (250ml)
10	4.5L	39
12	5.4L	45
14	6.3L	52
16	7.2L	59
18	8.1L	67
20	9L	75

Cleaning, Care & Maintenance



Note: Always switch off and disconnect the appliance from the power supply before cleaning.

Always allow the appliance to cool before cleaning.

1. Remove the inner bowl and wash in warm, soapy water. Do not use harsh abrasive cleaners or products that are not recommended for use on non-stick coatings.
2. Rinse and dry thoroughly.
3. Clean the exterior of the rice cooker with a damp cloth.
4. Ensure the heating plate is clean and free of food or other debris that could interfere with the cooking process.
5. Dry the heating plate thoroughly before use.

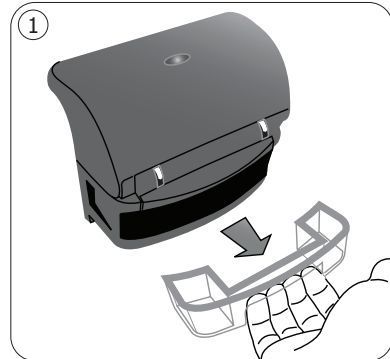

Water Collector (J300-A/CK698-A)

1. Remove the water collector from below the lid hinge by pulling outwards [Fig. 1]. Discard the water collected after each use.
2. Clean and re-locate the water collector.



For best performance, BUFFALO recommend that the appliance is cleaned after each day of operation.

Check the heating plate regularly to ensure it is free of any food debris.

IMPORTANT: Failure to maintain will invalidate your guarantee.

Troubleshooting

Fault	Probable Cause	Solution
The appliance is not working	The unit is not switched on	Check the unit is plugged in correctly and switched on
	Plug or lead is damaged	Call Apuro agent or qualified Technician
	Power supply	Check power supply
	The bowl is not in contact with the heating plate	Realign bowl
Rice is not thoroughly cooked	The bowl is not in contact with the heating plate	Reposition bowl
	The bowl has become deformed	Replace bowl
	Not enough water	Increase the amount of water used
Rice is overcooked	Too much water	Decrease the amount of water used
No power	Auto re-set activated	Allow product to cool for 30 minutes

Technical Specifications

Model	Voltage	Power	Current	Capacity	Weight	Dimensions H x W x D mm
J300-A	220-240V~ 50/60Hz	1950W	8.5A	13 litres	9.5kg	345 x 460 x 400
CK698-A	220-240V~ 50/60Hz	2850W	12.4A	20 litres	15.5kg	415 x 480 x 560
CB944-A	220-240V~ 50/60Hz	2950W	12.8A	23 litres	11kg	395 x 560 x 485
CN324-A	220-240V~ 50/60Hz	1550W	6.8A	10 litres	5.5kg	350 x 380 x 320

Electrical Wiring

The plug is to be connected to a suitable mains socket.

This appliance is wired as follows:

- Live wire (coloured brown) to terminal marked L
- Neutral wire (coloured blue) to terminal marked N
- Earth wire (coloured green/yellow) to terminal marked E

This appliance must be earthed.



If in doubt consult a qualified electrician.

Electrical isolation points must be kept clear of any obstructions. In the event of any emergency disconnection being required they must be readily accessible.

Compliance

The product must not be disposed of as household waste. To help prevent possible harm to human health and/or the environment, the product must be disposed of in an approved and environmentally safe recycling process. For further information on how to dispose of this product correctly, contact the product supplier, or the local authority responsible for waste disposal in your area.

APURO parts have undergone strict product testing in order to comply with regulatory standards and specifications set by international, independent, and federal authorities.



APURO products have been approved to carry the following symbol:

All rights reserved. No part of these instructions may be produced or transmitted in any form or by any means, electronic, mechanical, photocopying, recording or otherwise, without the prior written permission of APURO.

Every effort is made to ensure all details are correct at the time of going to press, however, APURO reserve the right to change specifications without notice.

DECLARATION OF CONFORMITY

- Conformanceverklaring • Déclaration de conformité • Konformitätserklärung • Dichiarazione di conformità •
• Declaración de conformidad • Declaração de conformidade

Equipment Type • Uitrustingstype • Type d'équipement • Gerätetyp • Tipo di apparecchiatura • Tipo de equipo • Tipo de equipamento		Model • Modèle • Modell • Modello • Modelo • Malli
Rice Cooker - 6Ltr Jumbo Rice Cooker - 9Ltr Commercial Rice Cooker - 23Ltr Rice Cooker - 4.2L		J300-A CK698-A CB944-A CN324-A
Application of Territory Legislation & Council Directives(s) Toepassing van Europese Richtlijn(en) • Application de la/des directive(s) du Conseil • Anwendbare EU-Richtlinie(n) • Applicazione delle Direttive • Aplicación de la(s) directiva(s) del consejo • Aplicação de directiva(s) do Conselho	Electrical safety EN 60335-1:2012 +A11:2014 EN 60335-2-15:2016 EN 62233:2008 Electro-Magnetic Compatibility EN 55014-1: 2017 EN 55014-2: 2015 EN 61000-3-2: 2014 EN 61000-3-3: 2013	
Producer Name • Naam fabrikant • Nom du producteur • Name des Herstellers • Nome del produttore • Nombre del fabricante • Nome do fabricante		Apuro

I, the undersigned, hereby declare that the equipment specified above conforms to the above Territory Legislation, Directive(s) and Standard(s).

Ik, de ondergetekende, verklaar hierbij dat de hierboven gespecificeerde uitrusting goedgekeurd is volgens de bovenstaande Richtlijn(en) en Standaard(en).

Je soussigné, confirme la conformité de l'équipement cité dans la présente à la / aux Directive(s) et Norme(s) ci-dessus
Ich, der/die Unterzeichnende, erkläre hiermit, dass das oben angegebene Gerät der/den oben angeführten Richtlinie(n) und Norm(en) entspricht.

Il sottoscritto dichiara che l'apparecchiatura di sopra specificata è conforme alle Direttive e agli Standard sopra riportati.
El abajo firmante declara por la presente que el equipo arriba especificado está en conformidad con la(s) directiva(s) y estándar(es) arriba mencionadas.

Eu, o abaixo-assinado, declaro que o equipamento anteriormente especificado está em conformidade com a(s) anterior(es) Directiva(s) e Norma(s)

Date • Data • Datum • Data • Fecha • Data	3 rd December 2020	
Signature • Handtekening • Signature • Unterschrift Firma • Firma • Assinatura	DocuSigned by: <i>Ashley Hooper</i> B39382C9FD9C478...	DocuSigned by: <i>Josie Holt</i> 3582E210C4054DA...
Full Name • Volledige naam • Nom et prénom • Vollständiger Name • Nome completo • Nombre completo • Nome por extenso	Ashley Hooper	Josie Holt
Position • Functie • Fonction • Position • Qualifica • Posición • Função	Technical & Quality Manager	Commercial Manager/ Responsible Supplier
Producer Address • Adres fabrikant • Adresse du producteur • Anschrift des Herstellers • Indirizzo del produttore • Dirección del fabricante • Morada do fabricante	Fourth Way, Avonmouth, Bristol, BS11 8TB United Kingdom	15 Bagdally Road, Campbelltown NSW 2560





J300-A_CK698-A_CB944-A_CN324-A_A5_v6_20210226