

ROKINON 4[®]

85mm F1.4 AF Nikon F Mount Instruction Manual



Thank you for purchasing the Rokinon AF 85mm F1.4 lens. It is a high performance prime autofocus optic designed exclusively for Nikon F mount Interchangeable lens cameras. Please note that supported functions may vary according to the camera model. For Nikon Z mirrorless cameras an adapter is required.

Advantages

- The Rokinon AF 85mm F1.4 is designed for optimal quality imaging with the most advanced Nikon Full Frame image sensor cameras.
- Its 85mm focal length, excellent center resolution, an aperture of F1.4 for great background separation and beautiful bokeh provide the essential components necessary for great portraiture.
- It performs equally as well on Nikon APS-C sensor cameras as a high speed 127.5 mm equivalent AF telephoto lens.

- The AF 85mm F1.4 F lens is equipped with a variety of advanced lens technologies, including a Hybrid Aspherical element that allow for a more compact and lightweight design that minimizes aberrations, controls distortion, and provides excellent resolution.

- Autofocusing is performed by a single inner focusing lens group and two Linear Ultrasonic Motors (LSM's) that provides very fast, precise and quiet operation.

- Its size, shape and grip have been ergonomically designed for enhanced stability and comfortable use.

- Weather sealing and a robust all metal design provide dust and moisture resistance with a luxurious look and excellent durability.

Cautions

To maintain your safety and prevent damage to the lens, please fully familiarize yourself with the following:

- Do not look directly at the sun through the lens as it may seriously impair your vision.
- Do not to apply excessive force when attaching the lens to the camera as it may cause damage to the lens or your camera.
- The lens is a precision optical product, so dropping or excessive impact may cause product failure.
- Attach or detach the lens only while the camera is turned off.
- Be careful not to touch or contaminate the gold contacts on the mount as it can adversely affect communication with the camera.
- Protect the lens from water, high humidity and excessive heat.
- Always store the lens with the lens cap on in a dry and well ventilated location out of direct sunlight. Direct sunlight passing through the lens could become concentrated enough to cause a fire.

- Avoid subjecting the lens to drastic temperature changes such as moving from a very cold outdoors location to a warm indoors location. This can cause moisture in the air to condense inside or on the outside of the lens and lead to failure or mold production. Before taking the lens indoors from a cold outdoors location, put the lens in a plastic bag or sealed camera bag and remove it only when the lens has warmed up to room temperature.

CAUTION

! When mounting the lens make sure that it clicks in place otherwise it may detach and cause damage or injury.



! Do not apply excessive force on the lens when it is attached to the camera. It may damage the lens and camera mount.



! Ensure that the lens is operating properly by testing it on your camera before shooting an important event.



! Do not modify or try to repair the lens as this will void the warranty.



! Do not leave the lens in direct sunlight as this could cause a fire.



! Do not look directly at the sun through a camera with a lens attached as it may damage your eyesight.



Cleaning

- It is extremely important before cleaning to dust off the lens surface using a lens blower or a soft brush to remove any foreign particles or grit that could scratch the lens.
- Using a clean microfiber lens cloth, gently wipe the lens in a circular motion from the center outwards towards the edges of the glass.

- If stubborn spots remain, put only one or two small drops of ethanol or reputable lens cleaner on the microfiber cloth and repeat the circular cleaning process. **DO NOT USE AN ORGANIC SOLVENT SUCH AS PAINT THINNER, ALCOHOL, OR BENZENE.**

Included Components

- Front Lens Cap
- Rear Lens Cap
- Lens Hood
- Soft Lens Pouch
- Instruction Manual
- Warranty Card

Attaching the Lens

- Remove the rear lens cap and the camera body cap.

- Align the white index mark (dot) on the lens barrel with the white index mark (dot) on the lens mount of the camera.

- Do not press the lens release button on the camera when mounting the lens.

- Insert the lens into the camera mount and rotate it counterclockwise until it "clicks" and locks in place. Do not insert the lens at an angle.

- Remove the front lens cap when you are ready to shoot.

Detaching the Lens

- Attach the front lens cap.

- While holding down the lens release button on the camera body, rotate the lens clockwise until it stops and separate the lens from the body.

- Attach the rear lens cap.

Parts

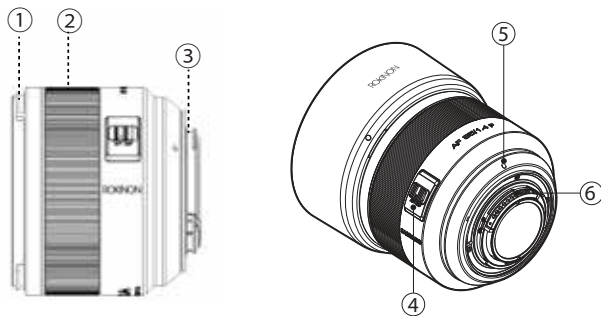

- ① Hood index mark
- ② Manual focus ring
- ③ Lens mount
- ④ AF/MF conversion switch
- ⑤ Lens mount index mark
- ⑥ Contacts

Focusing

Nikon interchangeable cameras offer various methods of focusing. For detailed information regarding the available focus mode settings for your particular model, refer to the instruction manual of your camera.

- Set the AF/MF switch to "AF" for auto focus operation.



- For manual focus operation set the switch to "M". Manual Focus allows you instead of the camera to adjust the focus by rotating the manual focus ring on the lens. Manual focus can be an easier method than autofocus when shooting portraits where you want to precisely keep focus on the subjects eyes.

Mounting a Filter

The lens is equipped with a non-rotating filter mount on the front of the lens that accepts 77mm size filters.

- Only one filter typically should be mounted at one time.
- If two or more filters are mounted at the same time, vignetting may occur.

Lens Hood

The supplied hood is designed specifically for the Rokinon AF 85mm F1.4 lens for optimum effectiveness. It should be used at all times to help prevent contrast reducing flare, provide better contrast and for added protection.

- To mount the hood, align the white index mark (dot) of the hood with the white hood index mark (dot) of the lens and rotate the hood clockwise until you hear and feel it click in place.
- To remove the hood, grasp it firmly and turn counterclockwise.

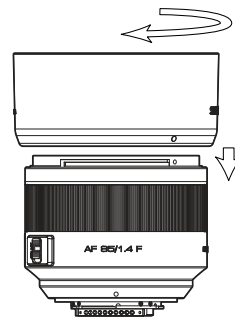

Product Specifications

Model name	IO85AF-N	
Aperture range	F1.4 ~ 16	
Angle of View	Full Frame	28.4°
	APS-C	19.0°
Optical construction	9 Elements in 7 Groups (Including 1 Hybrid Aspherical Lens)	
Minimum focusing distance	2.95ft (0.90m)	
Maximum shooting magnification	x 0.11	
Filter size	77mm	
Number of aperture blades	9	
Maximum diameter X length	3.46"x 2.93" (88.0 x 74.5mm)	
Weight	16.93oz (480g)	

- The minimum focus is the distance from the image sensor to the object.
- The product specifications and exterior are subject to change without notice.

Contact

Elite Brands Inc.
Rokinon Division
New York, NY 10005

Toll Free: 800.441.1100
Phone: 212.947.7100 support@rokinon.com

rokinon.com
facebook.com/rokinonlenses

ROKINON® is owned and operated solely by Elite Brands Inc.

Notes