

SAMYANG • 100mm T3.1 ED UMC MACRO (for Cinema) Instruction Manual

We believe that this new 100mm T3.1 ED UMC MARCO lens for video recording will give you a special photographic experience.

The 100mm T3.1 ED UMC MARCO lens completes an optical system based on superior optical technologies, and maintains excellent resolution by adopting a high refractive low dispersive lens and an UMC (Ultra Multi Coating).

Advantages of the 100mm T3.1 ED UMC MARCO

- 35mm full frame image size.
- It compensates for aberrations by using a high refractive low dispersive lens and high class optical glass, and at the fully opened position, produces a high resolution and a high contrast at the center of the lens as well as around the periphery.
- Produces smooth focusing by means of the aperture design, which comes close to a circular shape with its 9 diaphragm blades.
- The hood and UMC(Ultra Multi Coating) design suppresses flaring and ghost images.
- Robust durability with a high strength aluminum alloy body.
- Smooth control when a follow focus is attached since the lens is equipped with a gear for the focus and aperture.
- This lens is applicable on various purposes for taking pictures not only for close-ups but also landscape and portrait as well as normal lens.

The 100mm T3.1 ED UMC MARCO lens for video recording is designed with its own mount. You can mount the lens directly onto the camera without using an additional adaptor.

- Please read this instruction manual carefully and use it accordingly.
- Please read the 'Safety Precautions' at the back of this instruction manual prior to use.

● Please read this instruction manual prior to use. ●

※ When the upper part of image is dark, please follow below instruction.

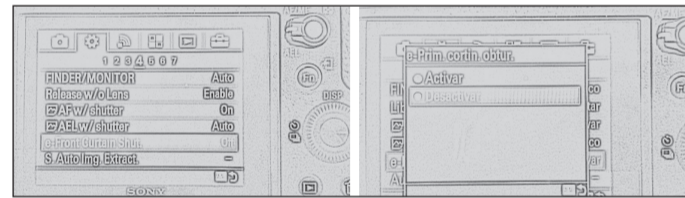

- Select fourth function of setting mode.
- Set "e-Front Curtain shut" off.
(The above instruction is given based on Sony E. The camera settings may vary depends on the model or due to a menu upgrade. Please refer to the camera manual or contact the camera manufacturer for more information.)

○ Samsung NX Mount

- Record a video in A, M or ∞ mode.
- Please note that while recording a video the shutter speed is limited to a minimum of 1/30.

(The procedures above are for the NX-200. The settings for the camera or the menu may vary based on the camera model or due to a functional upgrade. Refer to the camera manual or contact the camera manufacturer for detailed information.)

○ Four Thirds FT Mount

- Record a video in ∞ , P, A, or M mode.
- Please note that while recording a video the shutter speed is limited to a minimum of 1/30.

(The procedures above are for the E-5. The settings for the camera or the menu may vary based on the camera model or due to a functional upgrade. Refer to the camera manual or contact the camera manufacturer for detailed information.)

○ Micro Four Thirds Mount

- Record a video in ∞ , P, A, or M mode.
- Please note that while recording a video the shutter speed is limited to a minimum of 1/30.

(The procedures above are for the E-5. The settings for the camera or the menu may vary based on the camera model or due to a functional upgrade. Refer to the camera manual or contact the camera manufacturer for detailed information.)

SAMYANG OPTICS CO., LTD.

- http://www.syoopt.co.kr
- Headquarters and Factory : 123 Jayumyeok 6-gil, MasanHoewon-gu, Changwon-si, Gyeongsangnam-do, Korea(Bongam-dong) (Masan Fee Trade Zone 2 P.O.BOX 340) Postal code: 630-500
TEL: 055) 250-5600 FAX : 055) 292-3135
- Sales department : 5th floor, 124, Yeoksam-ro, Gangnam-gu, Seoul, Korea (Yeoksam-dong Chungbo building) Postal code: 135-933
TEL: 02) 784-9961 FAX: 02) 784-1440

1. Component Names

[Figure]

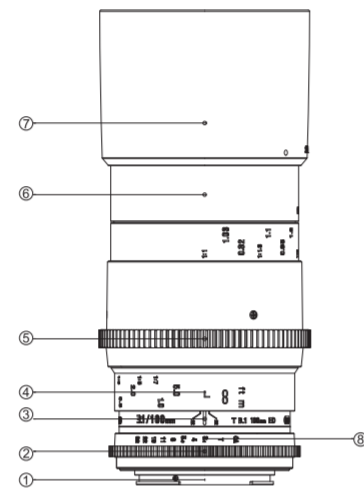

- Mount (camera locking area)
- Gear for aperture adjustment
- Distance scale indicator mark
- Focus scaling
- Gear for focus adjustment
- Hood locking tube
- Hood
- T number

2. Attaching and Detaching

The 100mm T3.1 ED UMC MARCO lens mount is uniquely designed for Canon, Nikon (Fujifilm) F, Pentax (Samsung GX) K, Sony (Minolta) a, Cannon M, Sony E, Fujifilm X, Samsung NX, Four-thirds and Micro four-thirds cameras.

[Attaching]

Gently hold the lens hood, align the camera mount attachment point with the attachment reference point or line on the lens, push the lens into the camera and gently rotate the lens 90 degrees clockwise from the front view, until it makes a clicking sound.

[Detaching]

Gently hold the lens hood, press the lens release button on the camera, and turn the lens counterclockwise to detach the lens.

3. Focus Adjustment

When using the 100mm T3.1 ED UMC MARCO lens, you can set the focus of a subject by turning the focus adjustment gear, since it is an MF (Manual Focus) adjustment lens.

[Nikon, Pentax K Mount]

- To change the focus from a subject that is far away to a subject that is close, Turn the focusing gear counterclockwise (from ∞ to 0.307) and focus on the clearest subject by using the indicator signal on the camera or by checking visually.
- To change the focus from a subject that is close to a subject that is far away, Turn the focusing gear clockwise (from 0.307 to ∞) and focus on the clearest subject using the indicator signal on the camera or by checking visually.

[Canon, Sony a, Cannon M, Sony E, Fujifilm X, Samsung NX, FT, MFT Mount]

- To change the focus from a subject that is far away to a subject that is close, Turn the focusing gear clockwise (from ∞ to 0.307) and focus on the clearest subject by checking visually.
- To change the focus from a subject that is close to a subject that is far away, Turn the focusing gear counterclockwise (from 0.307 to ∞) and focus on the clearest subject by checking visually.

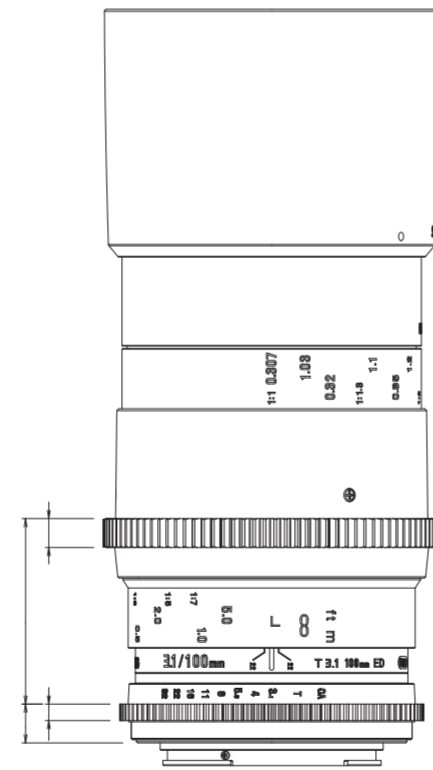

4. Brightness Control

You can set the brightness you want by turning the aperture adjustment gear when using the 100mm T3.1 ED UMC MARCO lens.

You can set T NO from 3.1 to 32.
(The aperture is a stepless control type, so it does not stop exactly.)

5. Mounting the Hood

The hood guarantees speedy, efficient, safe and precise installation, and enables you to enjoy shooting that is free from ghosting or flaring.

[Figure]

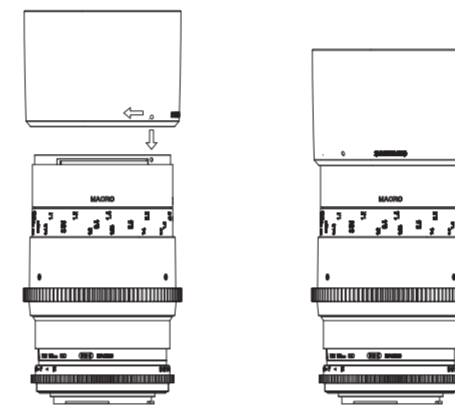

Align the attachment reference point on the hood with the reference point for a hood on the lens, push the hood onto the lens and turn the hood clockwise until it makes a clicking sound.

8. Troubleshooting

Symptoms	Cause	Countermeasures
A lens cannot be attached to the camera.	The reference point on the lens is not aligned with the lens attachment reference point on the camera.	Align the attachment reference point on the lens with the lens attachment reference point on the camera.
A lens cannot be detached from the camera.	Incorrect rotation direction for detaching the lens if you turn the lens while holding the camera, it may cause damage to the camera.	Hold down the lens release button on the camera, gently turn the lens toward the lens attachment/detachment reference point marked on the camera, and then pull the lens away.
Blurry images	Incorrect focusing Camera shake, or insufficient shutter speed.	Turn the focusing ring while checking the subject with the indicator in the camera or checking visually to set the focus until the subject is clear, and then press the shutter. After selecting a shutter speed of 1/125 sec or faster, steady the camera and take a photograph.
Automatic focusing does not work properly.	A manual focusing lens has trouble with automatic focusing.	Turn the focusing ring to focus on a subject.
The pictures are too dark or too bright.	The exposure is incorrect.	Set the aperture adjustment ring of the lens correctly.
The camera flash is not synchronized to the camera.	With a non-CPU lens, the camera flash may not be geared to some cameras.	Refer to the camera manual.
There is no camera finder indication or display.	This lens doesn't have electronic contacts, so there is no electronic communication with the camera.	No problem with shooting.
Zoom failure.	This lens is a single lens.	
The lens can't be attached to other cameras.	This lens is designed for a specific mount type.	Purchase the designated lens mount.
You want to attach our 2X or 1.4X converter lens.	Our converter is designed for the 1 (M42 SCREW) mount only, thus it cannot be used with this product.	You can use each company's own mount converter. However, be aware that auto focusing is unavailable.

6. Camera Settings

Some cameras require special settings when using this lens.

○ Canon Mount

- Record a video in Av, Tv, P, CA, \square or M mode.
- Please note that while recording a video the shutter speed is limited to a minimum of 1/30.

(The procedures above are for the 5D MARKII. The settings for the camera or the menu may vary based on the camera model or due to a functional upgrade. Refer to the camera manual or contact the camera manufacturer for detailed information.)

○ Nikon Mount

Please refer to the following and set the camera when necessary.

- Record a video in M or A mode.
- Adjust the exposure using the dial steps +5 to -5.

(The procedures above are for the D7000. The settings for the camera or the menu may vary based on the camera model or due to a functional upgrade. Refer to the camera manual or contact the camera manufacturer for detailed information.)

○ Pentax K Mount

- Record a video in ∞ mode.
- Please note that while recording a video the shutter speed is limited to a minimum of 1/30.

(The procedures above are for the K-30. The settings for the camera or the menu may vary based on the camera model or due to a functional upgrade. Refer to the camera manual or contact the camera manufacturer for detailed information.)

9. Safety Precautions

The following precautions are divided into two types according to the level of danger.

Warning

If this instruction is not followed, it may cause death or severe injury to the user.

⚠ Don't look at the sun through the lens. It may cause blindness.

⚠ Don't look at the sun through children's reach. It may drop or fall down, causing injury.

Caution

If this instruction is not followed, it may cause damage or injury to the user.

⚠ Requires caution. Inside the program 1 shows contents of prohibitions. (The pictogram on the left shows the caution for gelatin.)

⚠ Shows prohibition. Inside the program 1 shows contents of prohibition. (The pictogram on the left shows the prohibition of disassembly.)

⚠ Shows instruction. Inside the program 1 shows contents of instructions. (It shows instruction of precaution in the pictogram on the left.)

⚠ Don't touch the sun through the lens. It may cause blindness.

⚠ Don't touch the sun through children's reach. It may drop or fall down, causing injury.

⚠ Don't touch the sun through children's reach. It may drop or fall down, causing injury.

⚠ Don't touch the sun through children's reach. It may drop or fall down, causing injury.

WARNING!
Do not wet this product or expose it to a moist environment. It may cause a fire or electric shock.

CAUTION!

- Don't use this product or store it close to devices that generate heat i.e., heaters, thermal regulators, stoves, stereo amplifiers.
- Do not expose the lens to drastic temperature changes.
- Do not touch the surface of the lens with your hand, or let it come into contact with sharp objects.
- Do not drop the lens.
- Do not soak the lens in water, and avoid water splashing onto the lens.
- If there are foreign bodies on the lens, use a lens cleaning kit only.

○ Sony a Mount

- Record a video in A, S, P or M mode.

(The procedures above are for the A580. The settings for the camera or the menu may vary based on the camera model or due to a functional upgrade. Refer to the camera manual or contact the camera manufacturer for detailed information.)

○ Canon M Mount

- Record a video in Av, Tv, P, CA or M mode.
- Please note that while recording a video the shutter speed is limited to a minimum of 1/30.

(The procedures above are for the Cannon M. The settings for the camera or the menu may vary based on the camera model or due to a functional upgrade. Refer to the camera manual or contact the camera manufacturer for detailed information.)

○ Fujifilm X Mount

- Record a video in ∞ mode.

(The procedures above are for the X-Pro1. The settings for the camera or the menu may vary based on the camera model or due to a functional upgrade. Refer to the camera manual or contact the camera manufacturer for detailed information.)

○ Sony E Mount

- Record a video in A, S, P or M mode.
- Adjust the exposure by rotating the dial at the back of the camera.

(The procedures above are for the NEX-5. The settings for the camera or the menu may vary based on the camera model or due to a functional upgrade. Refer to the camera manual or contact the camera manufacturer for detailed information.)

MEMO