

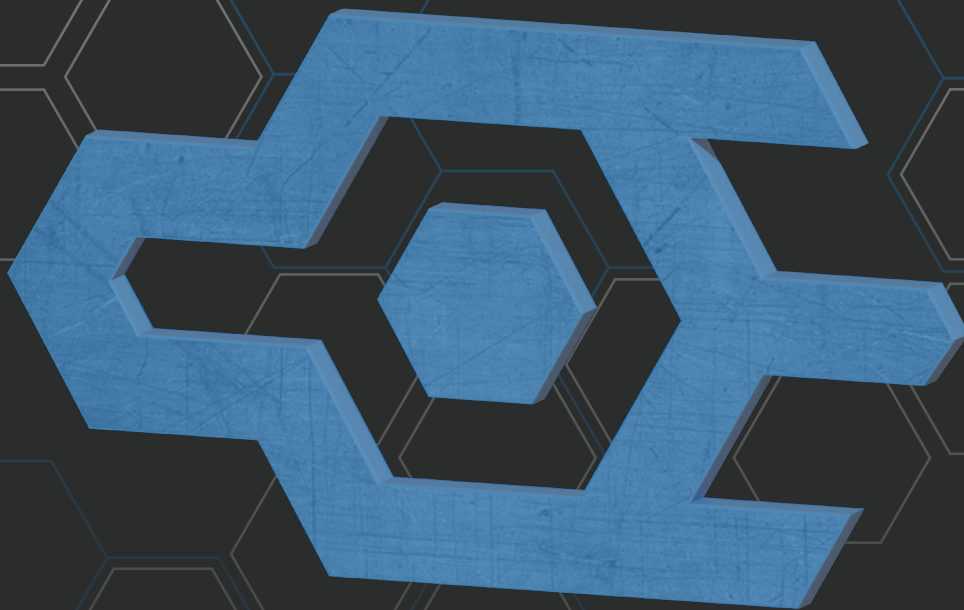

PROTOS



2023

VOYAGER ELECTRICAL CHAIN HOISTS

Electrical chain hoists have a leading role in the modern entertainment and exhibition industry and hold a predominant position in current and future rigging.

Following the AEGIS Load Measuring Systems and ADJUTOR Rigging Gear, PROTOS introduces the VOYAGER electrical chain hoist family. A versatile, state of the art hoist range based on the market's rigging needs.

Ranging from the 250 kg S model to the 2500 kg XXL model, single fall and various speeds and voltages are available as standard features. All models are rated at IP65 ensuring worry free outdoor use.

VOYAGER hoists can be controlled by any universal controllers with either direct, (DC) or low voltage (LV) control. Innovative design, small dimensions and unique low self-weight for easy handling, this is what our hoists are known for.

The Voyager hoist range is available in D8, D8+ or BGV-C1 composition and can be fitted with limit switches, load measuring capabilities and encoders. All models come with a 3 year warranty period.

The entire PROTOS VOYAGER hoist range has its slip clutch installed in front of the braking system and is therefore positioned outside the "drive train". This protects the chain hoist from overloading.

PROTOS VOYAGER

Safe and uncompromised lifting made in Europe and prepared for the future



S Models	4
M Models	6
L Models	8
XL Models	10
XXL Models	12
Accessories	14
Service	16





VOYAGER MODEL S

The model S is the smallest hoist in the VOYAGER range. Weighing only 12 kg, this little powerhouse lifts up to 500 kg in D8 and 250 kg in D8+ configuration. VOYAGER hoists feature a modular design and, even with a second brake, remain compact. The small size of this hoist makes it ideal for transportation, saving space and costs.

The model S is equipped with a 3-stage self-contained gear, while the helical gearing with geometric optimisation and the 5-pocket load wheel ensure silent running. The case hardened and manganese phosphate profile steel chain provides about 15% more capacity at an identical nominal diameter when compared to the traditional round steel chain. This increases the life span due to better protection against corrosion and decreasing wear when running dry. The larger cross-sectional area reduces wear and increases the lifetime of the chain.

All S models are single fall. The load hook with its stable, guided hook latch and safety rubber buffer provides maximum safety. The hoist body and components are treated with KTL dip paint coating for protection against environmental influences and abuse. Textile chain bags for various lifting heights available. A unique feature of the hoist is the IP65 protection class making it dust and water proof. The Voyager S is perfectly suitable for outdoor use, even under the most difficult and rainy conditions.

Model S	D8	Model S+	D8+
Lifting Capacity	400 kg	Lifting Capacity	250 kg
Chain Safety Factor	5:1	Chain Safety Factor	8:1
Lifting Speed	4/8 m/min	Lifting Speed	4/8 m/min
Operating Voltages	3Ph-400V-50Hz 3Ph-230V-50Hz 1Ph-230V-50Hz 1Ph-115V-50Hz 3Ph-200v-50Hz 3Ph-200v-60Hz	Operating Voltages	3Ph-400V-50Hz 3Ph-230V-50Hz 1Ph-230V-50Hz 1Ph-115V-50Hz 3Ph-200v-50Hz 3Ph-200v-60Hz
Protection Class	IP65	Protection Class	IP65
Motor Power	0,25kW	Motor Power	0,25kW
Current At Full Load	1,8A	Current At Full Load	1,8A
Classification DIN EN 14492 (FEM)	A3(M3)	Classification DIN EN 14492 (FEM)	A5(M5)
Duty Factor	40%	Duty Factor	40%
Noise Level	65dBA	Noise Level	65dBA
Load Wheel	5 Pocket Wheel	Load Wheel	5 Pocket Wheel
Load Chain acc. EN 818-7	3.75mm x 10.75mm	Load Chain acc. EN 818-7	3.75mm x 10.75mm
Number of Chain Falls	1	Number of Chain Falls	1
Chain Weight Per Meter	0.34 kg	Chain Weight Per Meter	0.34 kg
Self Weight Hoist Body	12 kg	Self Weight Hoist Body	12 kg
Hoist Control Type	DC/LV	Hoist Control Type	DC/LV
Limit Switch Types	Rotary/External Switch	Limit Switch Types	Rotary/External Switch
Power Connector Type	CEE Red 16A 4P	Power Connector Type	CEE Red 16A 4P
Control Connector Type	CEE Yellow 16A 4P	Control Connector Type	CEE Yellow 16A 4P
Low Voltage Control Voltage	24V/42V	Low Voltage Control Voltage	24V/42V
Double Brake	Optional	Double Brake	Standard

Suspension	Falls	A1 mm	A2 mm	B1 mm	B2 mm	C1 mm	C2 mm	H1 mm
Eyebolt	1	206	30	368	20	134	39	346
Hook	1	206	30	368	20	134	90	397

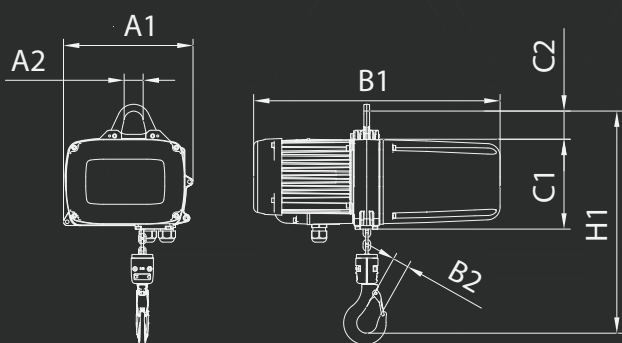

Eyebolt Suspension

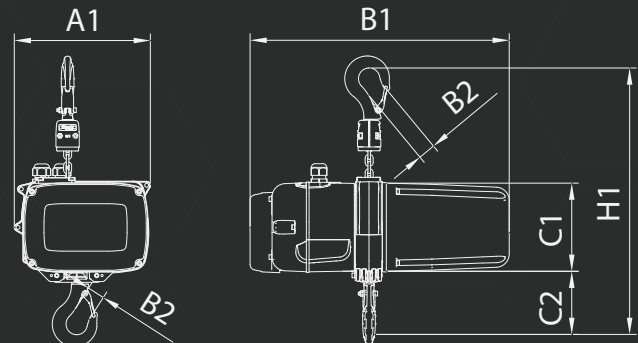

Rotatable Hook Suspension



VOYAGER MODEL **m**

The model M is available in 2 body sizes, the D8 version has a lifting capacity of 500 kg and weighs a mere 12 kg, making it the lightest weighing hoist in this range. The D8+ and C-1 versions have a larger body and a self weight of 23 kg. Lifting capacity at D8+ level is 500 kg and 400 kg in C-1 configuration.

The entire Voyager range comes equipped with self contained helical gears and 5 pocket load wheels, ensuring silent running. All configurations of in the model M range are rated with the unique IP65 protection class. The case hardened and manganese phosphate treatment of the chain increases the hoists lifespan due to better protection against corrosion and decreases wear when running dry.

In its D8 configurations the model M is available with 4m/min lifting speed, while the D8+ and C1 variants are available as both 4 and 8m/min speeds and can be ordered with either direct or low voltage control. All model M hoists are single fall. The hoist body and components are treated with KTL dip paint coating for protection against environmental influences and abuse. PROTOS offers Textile chain bags for various lifting heights for this hoist.

The Voyager M is perfectly suitable for outside use, even under the most difficult and rainy conditions.

Model M	D8	Model M+	D8+	Model MC1	C-1
Lifting Capacity	500 kg	Lifting Capacity	500 kg	Lifting Capacity	400 kg
Chain Safety Factor	5:1	Chain Safety Factor	8:1	Chain Safety Factor	10:1
Lifting Speed	4 m/min	Lifting Speed	4/8 m/min	Lifting Speed	4/8 m/min
Operating Voltages	3Ph-400V-50Hz 3Ph-230V-50Hz 3Ph-200v-50Hz 3Ph-200v-60Hz	Operating Voltages	3Ph-400V-50Hz 3Ph-230V-50Hz 1Ph-230V-50Hz 1Ph-115V-50Hz 3Ph-200v-50Hz 3Ph-200v-60Hz	Operating Voltages	3Ph-400V-50Hz 3Ph-230V-50Hz 1Ph-230V-50Hz 1Ph-115V-50Hz 3Ph-200v-50Hz 3Ph-200v-60Hz
Protection Class	IP65	Protection Class	IP65	Protection Class	IP65
Motor Power	0,38kW	Motor Power	0,55kW	Motor Power	0,55kW
Current At Full Load	2,4A	Current At Full Load	1,8A	Current At Full Load	1,8A
Classification DIN EN 14492 (FEM)	A3(M3)	Classification DIN EN 14492 (FEM)	A5(M5)	Classification DIN EN 14492 (FEM)	A5(M5)
Duty Factor	25%	Duty Factor	40%	Duty Factor	40%
Noise Level	65dBA	Noise Level	60dBA	Noise Level	60dBA
Load Wheel	5 Pocket Wheel	Load Wheel	5 Pocket Wheel	Load Wheel	5 Pocket Wheel
Load Chain acc. EN 818-7	4.1mm x 11.5mm	Load Chain acc. EN 818-7	5.25mm x 15mm	Load Chain acc. EN 818-7	5.25mm x 15mm
Number of Chain Falls	1	Number of Chain Falls	1	Number of Chain Falls	2
Chain Weight Per Meter	0.43 kg	Chain Weight Per Meter	0.69 kg	Chain Weight Per Meter	0.69 kg
Self Weight Hoist Body	12 kg	Self Weight Hoist Body	23 kg	Self Weight Hoist Body	24 kg
Hoist Control Type	DC/LV	Hoist Control Type	DC/LV	Hoist Control Type	DC/LV
Limit Switch Types	Rotary/External Switch	Limit Switch Types	Rotary/External Switch	Limit Switch Types	Rotary/External Switch
Power Connector Type	CEE Red 16A 4P	Power Connector Type	CEE Red 16A 4P	Power Connector Type	CEE Red 16A 4P
Control Connector Type	CEE Yellow 16A 4P	Control Connector Type	CEE Yellow 16A 4P	Control Connector Type	CEE Yellow 16A 4P
Low Voltage Control Voltage	24V/42V	Low Voltage Control Voltage	24V/42V	Low Voltage Control Voltage	24V/42V
Double Brake	Optional	Double Brake	Standard	Double Brake	Standard

Suspension	Falls	A1 mm	A2 mm	B1 mm	B2 mm	C1 mm	C2 mm	H1 mm
D8 Eyebolt	1	206	30	368	20	134	39	346
D8 Hook	1	206	30	368	20	134	90	397
D8+ Eyebolt	1	272	40	414	24	162	49	447
D8+ Hook	1	272	40	414	24	162	127	525
C-1 Eyebolt	1	272	40	414	24	162	100	498
C-1 Hook	1	272	40	414	24	162	180	578

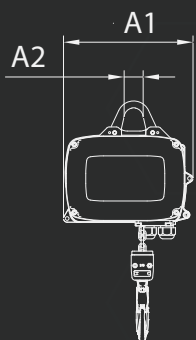

Eyebolt Suspension

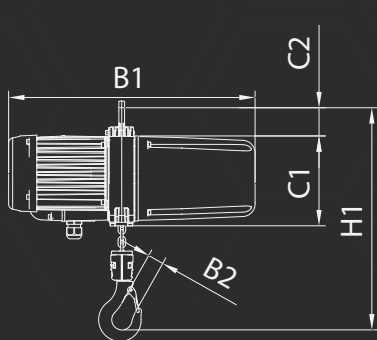

Rotatable Hook Suspension

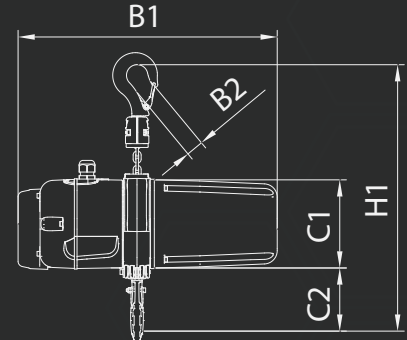
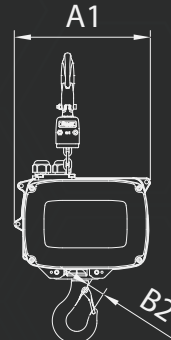



VOYAGER MODEL L

The VOYAGER model L, similar to the S, and M comes in 2 different body sizes. The D8 version, weighing in at merely 23 kg combined with its 1000 kg lifting capacity makes this model one of the most versatile hoists currently on the market. The model L also boasts a 1 ton lifting capacity in its D8+ configuration, while as a C-1 hoist it still manages a respectable 800 kg. Both the D8+ and C-1 variants clock in at 47 kg self weight due to the safety factors of respectively 8:1 for D8+ and 10:1 for C-1.

All models are rated at an IP65 protection class making them ideal for in and outdoor use in both temporarily or fixed installations. The case hardened and manganese phosphate treatment of the chain increases the hoist's life span due to better protection against corrosion while decreasing wear when running dry.

In its D8 configurations the model L is available with 4m/min lifting speed, while the D8+ and C1 variants are available as both 4 and 8m/min speeds and can be ordered with either direct or low voltage control. All model L hoists are single fall. The hoist body and components are treated with KTL dip paint coating for protection against environmental influences and abuse. PROTOS offers textile chain bags for various lifting heights for this hoist.

The Voyager L is perfectly suitable for outside use, even under the most difficult and rainy conditions.

The Voyager "L" is undeniably the ultimate workhorse in many rental fleets due to its unique features such as the IP65 rating, low self weight versus high lifting capacity while remaining single fall even in C1 configuration.

Model L	D8	Model L+	D8+	Model LC1	C-1
Lifting Capacity	1000 kg	Lifting Capacity	1000 kg	Lifting Capacity	800 kg
Chain Safety Factor	5:1	Chain Safety Factor	8:1	Chain Safety Factor	10:1
Lifting Speed	4 m/min	Lifting Speed	4/8 m/min	Lifting Speed	4/8 m/min
Operating Voltages	3Ph-400V-50Hz 3Ph-230V-50Hz 3Ph-200v-50Hz 3Ph-200v-60Hz	Operating Voltages	3Ph-400V-50Hz 3Ph-230V-50Hz 1Ph-230V-50Hz 1Ph-115V-50Hz 3Ph-200v-50Hz 3Ph-200v-60Hz	Operating Voltages	3Ph-400V-50Hz 3Ph-230V-50Hz 1Ph-230V-50Hz 1Ph-115V-50Hz 3Ph-200v-50Hz 3Ph-200v-60Hz
Protection Class	IP65	Protection Class	IP65	Protection Class	IP65
Motor Power	0,76kW	Motor Power	1,5kW	Motor Power	1,5kW
Current At Full Load	2,6A	Current At Full Load	3,6A	Current At Full Load	3,6A
Classification DIN EN 14492 (FEM)	A3(M3)	Classification DIN EN 14492 (FEM)	A5(M5)	Classification DIN EN 14492 (FEM)	A5(M5)
Duty Factor	25%	Duty Factor	40%	Duty Factor	40%
Noise Level	60dBA	Noise Level	75dBA	Noise Level	75dBA
Load Wheel	5 Pocket Wheel	Load Wheel	5 Pocket Wheel	Load Wheel	5 Pocket Wheel
Load Chain acc. EN 818-7	5.7mm x 16mm	Load Chain acc. EN 818-7	7.45mm x 23mm	Load Chain acc. EN 818-7	7.45mm x 23mm
Number of Chain Falls	1	Number of Chain Falls	1	Number of Chain Falls	1
Chain Weight Per Meter	0.84 kg	Chain Weight Per Meter	1.37 kg	Chain Weight Per Meter	1.37 kg
Self Weight Hoist Body	23 kg	Self Weight Hoist Body	47 kg	Self Weight Hoist Body	48 kg
Hoist Control Type	DC/LV	Hoist Control Type	DC/LV	Hoist Control Type	DC/LV
Limit Switch Types	Rotary/External Switch	Limit Switch Types	Rotary/External Switch	Limit Switch Types	Rotary/External Switch
Power Connector Type	CEE Red 16A 4P	Power Connector Type	CEE Red 16A 4P	Power Connector Type	CEE Red 16A 4P
Control Connector Type	CEE Yellow 16A 4P	Control Connector Type	CEE Yellow 16A 4P	Control Connector Type	CEE Yellow 16A 4P
Low Voltage Control Voltage	24V/42V	Low Voltage Control Voltage	24V/42V	Low Voltage Control Voltage	24V/42V
Double Brake	Optional	Double Brake	Standard	Double Brake	Standard

Suspension	Falls	A1 mm	A2 mm	B1 mm	B2 mm	C1 mm	C2 mm	H1 mm
D8 Eyebolt	1	272	40	414	24	162	49	447
D8 Hook	1	272	40	414	24	162	127	525
D8+ Eyebolt	1	337	52	514	24	212	58	558
D8+ Hook	1	337	52	514	24	212	123	623
C-1 Eyebolt	1	337	52	514	24	212	120	621
C-1 Hook	1	337	52	514	24	212	192	693

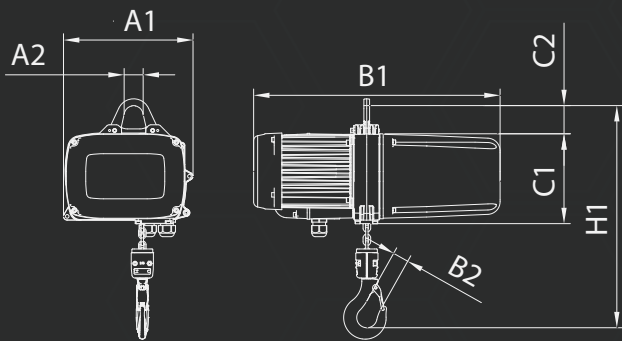

Eyebolt Suspension

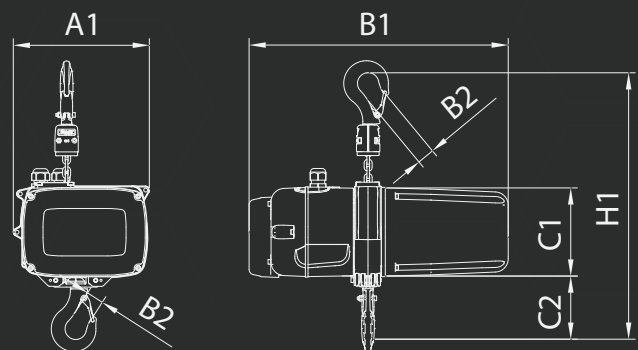

Rotatable Hook Suspension



VOYAGER MODEL XL

The VOYAGER model XL comes in one body size. The D8 version, weighing in at 46 kg with an significant lifting capacity of 2000 kg.

Similar as the rest of the VOYAGER range, the model XL operates using a single fall lifting chain which making this hoist unique within this lifting class due to half the chain length dramatically decreasing self weight. Single fall also reduces the risk of tangled lifting chain, a problem usually associated with hoists within this category.

The model XL is available with 4m/min lifting speed and can be ordered with direct or low voltage control (42V standard). The helical gearing with geometric optimisation and the 5 pocket load wheel ensure quiet operation. The case hardened and manganese phosphate treatment of the chain increases life span due to better protection against corrosion while decreasing wear when running dry. Textile chain bags for various lifting heights are available.

Model XL

D8

Lifting Capacity	2000kg
Chain Safety Factor	5:1
Lifting Speed	4 m/min
Operating Voltages	3Ph-400V-50Hz 3Ph-230V-50Hz 3Ph-200V-50Hz 3Ph-200V-60Hz
Protection Class	IP65
Motor Power	1.5kW
Current At Full Load	4.4A
Classification DIN EN 14492 (FEM)	A3(M3)
Duty Factor	25%
Noise Level	75dBA
Load Wheel	5 Pocket Wheel
Load Chain acc. EN 818-7	9.4mm x 27.4mm
Number of Chain Falls	1
Chain Weight Per Meter	1.64 kg
Self Weight Hoist Body	46 kg
Hoist Control Type	DC/LV
Limit Switch Types	Rotary/External Switch
Power Connector Type	CEE Red 16A 4P
Control Connector Type	CEE Yellow 16A 4P
Low Voltage Control Voltage	24V/42V
Double brake	Optional

Suspension	Falls	A1 mm	A2 mm	B1 mm	B2 mm	C1 mm	C2 mm	H1 mm
D8 Eyebolt	1	272	40	414	24	162	49	447
D8 Hook	1	272	40	414	24	162	127	525

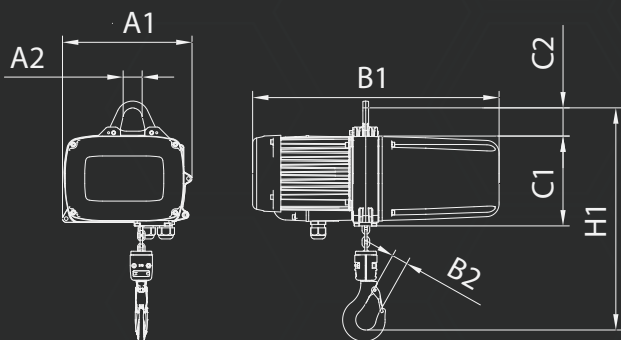

Eyebolt Suspension

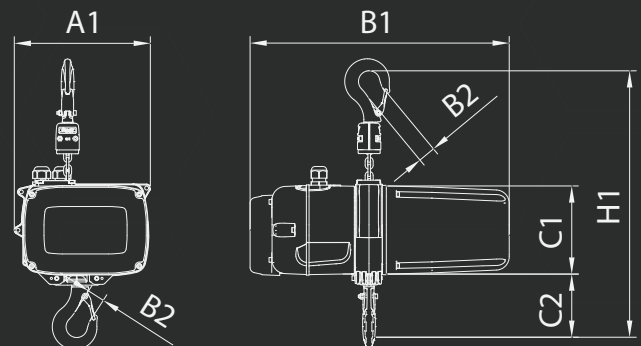

Rotatable Hook Suspension



VOYAGER MODEL **XXL**

The VOYAGER model XXL, similar to the S, M and L comes in 2 different body sizes. The D8 version, weighing in at 72 kg with an impressive lifting capacity of 2500 kg. The model XXL also boasts a 2.5 ton lifting capacity in its D8+ configuration, while as a C-1 hoist it still manages an incredible 2000 kg. Both the D8+ and C-1 variants clock in at 74 kg self weight due to the safety factors of respectively 8:1 for D8+ and 10:1 for C-1.

Similar as the rest of the VOYAGER range, the model XXL operates using a single fall lifting chain which making this hoist unique within this lifting class due to half the chain length dramatically decreasing self weight. Single fall also reduces the risk of tangled lifting chain, a problem usually associated with hoists within this category.

All 3 variants of the model XXL are available with 4 and 8m/min lifting speed and can be ordered with direct or low voltage control (42V standard). The helical gearing with geometric optimisation and the 5 pocket load wheel ensure quiet operation. The case hardened and manganese phosphate treatment of the chain increases life span due to better protection against corrosion while decreasing wear when running dry. Textile chain bags for various lifting heights are available.

The Voyager XXL is the ultimate heavy weight lifting champion and offers unmatched advantages over any other chain hoist available.

Model XXL **D8**

Lifting Capacity	2500 kg
Chain Safety Factor	5:1
Lifting Speed	4/8 m/min
Operating Voltages	3Ph-400V-50Hz 3Ph-230V-50Hz 1Ph-230V-50Hz 1Ph-115V-50Hz 3Ph-200v-50Hz 3Ph-200v-60Hz

Protection Class	IP65
Motor Power	2,2kW
Current At Full Load	6,1A
Classification DIN EN 14492 (FEM)	A3(M3)
Duty Factor	25%
Noise Level	75dBA
Load Wheel	5 Pocket Wheel
Load Chain acc. EN 818-7	9.4mm x 27.4mm
Number of Chain Falls	1
Chain Weight Per Meter	2.22 kg
Self Weight Hoist Body	72 kg
Hoist Control Type	DC/LV
Limit Switch Types	Rotary/External Switch
Power Connector Type	CEE Red 16A 4P
Control Connector Type	CEE Yellow 16A 4P
Low Voltage Control Voltage	24V/42V
Double Brake	Optional

Model XXL+ **D8+**

Lifting Capacity	2500 kg
Chain Safety Factor	8:1
Lifting Speed	4/8 m/min
Operating Voltages	3Ph-400V-50Hz 3Ph-230V-50Hz 1Ph-230V-50Hz 1Ph-115V-50Hz 3Ph-200v-50Hz 3Ph-200v-60Hz

Protection Class	IP65
Motor Power	2,2kW
Current At Full Load	6,1A
Classification DIN EN 14492 (FEM)	A5(M5)
Duty Factor	40%
Noise Level	75dBA
Load Wheel	5 Pocket Wheel
Load Chain acc. EN 818-7	11.75mm x 32.9mm
Number of Chain Falls	1
Chain Weight Per Meter	3.53 kg
Self Weight Hoist Body	72 kg
Hoist Control Type	DC/LV
Limit Switch Types	Rotary/External Switch
Power Connector Type	CEE Red 16A 4P
Control Connector Type	CEE Yellow 16A 4P
Low Voltage Control Voltage	24V/42V
Double Brake	Standard

Model XXL **C-1**

Lifting Capacity	2000 kg
Chain Safety Factor	10:1
Lifting Speed	4/8 m/min
Operating Voltages	3Ph-400V-50Hz 3Ph-230V-50Hz 1Ph-230V-50Hz 1Ph-115V-50Hz 3Ph-200v-50Hz 3Ph-200v-60Hz

Protection Class	IP65
Motor Power	2,2kW
Current At Full Load	6,1A
Classification DIN EN 14492 (FEM)	A5(M5)
Duty Factor	40%
Noise Level	75dBA
Load Wheel	5 Pocket Wheel
Load Chain acc. EN 818-7	11.75mm x 32.9mm
Number of Chain Falls	1
Chain Weight Per Meter	3.53 kg
Self Weight Hoist Body	75 kg
Hoist Control Type	DC/LV
Limit Switch Types	Rotary/External Switch
Power Connector Type	CEE Red 16A 4P
Control Connector Type	CEE Yellow 16A 4P
Low Voltage Control Voltage	24V/42V
Double Brake	Standard

Suspension	Falls	A1 mm	A2 mm	B1 mm	B2 mm	C1 mm	C2 mm	H1 mm
------------	-------	-------	-------	-------	-------	-------	-------	-------

D8	Eyebolt	1	382	75	614	35	237	118	698
D8	Hook	1	382	75	614	35	237	147	727
D8+	Eyebolt	1	382	62	614	41	237	111	732
D8+	Hook	1	382	62	614	41	237	204	825
C-1	Eyebolt	1	382	70	614	41	237	221	842
C-1	Hook	1	382	70	614	41	237	310	931

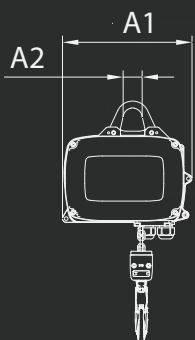

Eyebolt Suspension

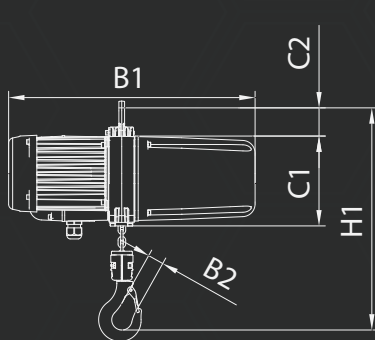

Rotatable Hook Suspension

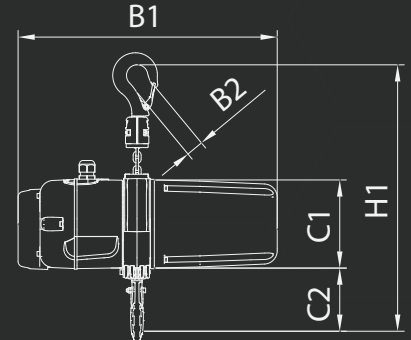
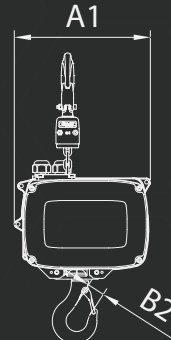

STANDARD FEATURES

Each of our hoists is shipped with the following features.



Design

- Compact and light
- Robust aluminium casing and cover for mobile and outdoor use
- Powerful built-in motor
- Drain holes

Brake

Reliable spring loaded DV-brake -
Safe braking of the load -

Optionally independent second brake on existing shaft (no cover extension required) -



Transmission

- Smooth running (65 dB)
- 3-step drive with helical gearing
- Permanent lubrication
- Self-contained gearbox

Hooks

Skeleton load and suspension hooks -
Hook safety latch fastened into position when closed -
Dampening system -



Polygonal connections

- All shaft-hub connections are built in a self-centering polygonal design
- Optimal power transmission
- Quick assembly and disassembly

Easy maintenance

Easy to maintain -
Good accessibility of wearing parts -
Quick and simple replacement -
No special tools required -
Two part chain guiding plate -



OPTIONAL UPGRADES

Aside from the range of features each VOYAGER hoists comes with, PROTOS also offers many optional features.

Geared limit switch

The upper and lower end position of the load hook can be set easily and precisely -
Optional 2 additional emergency stop contacts available -
Optional external limit switch -

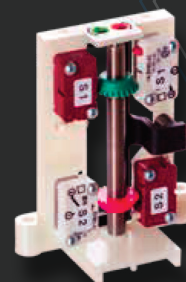

Load Measurement

Load sensor integrated in suspension -
Simple installation in special eyebolt or hook suspension -
Optional mechanical protection -
Output signal hook load sensor 0-10 or V 4 - 20 mA -

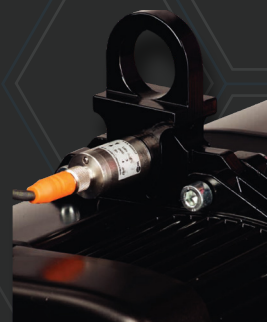

Positioning

Absolute or incremental encoder -
Encoder on chain wheel (no housing extension required) -
Optional encoder on drive shaft (housing extension required) -

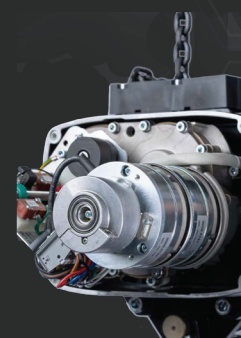
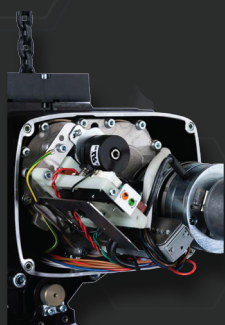

OPTIONAL ACCESSORIES

A comprehensive range of accessories enables users to accommodate hoists for any fixed or mobile job imaginable. Availability of accessories are dependent on the model.



Flight case

- Available for the entire VOYAGER range
- Heavy duty design

Cabling

Various lengths and types available such as power, motor and control cabling. Equipped with CEE connectors. Harting and Socapex are available for multicables, break-in and break-out adapters.



Beam trolleys

- Manual trolley for steel profiles
- For moving electrical and manual chain hoist manually
- Load wheels made of cast iron with ball bearings
- Side plates made of cast iron with fall and climbing protection
- Flange width infinitely variable

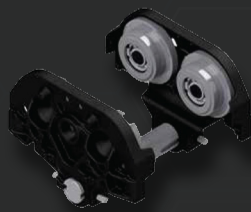

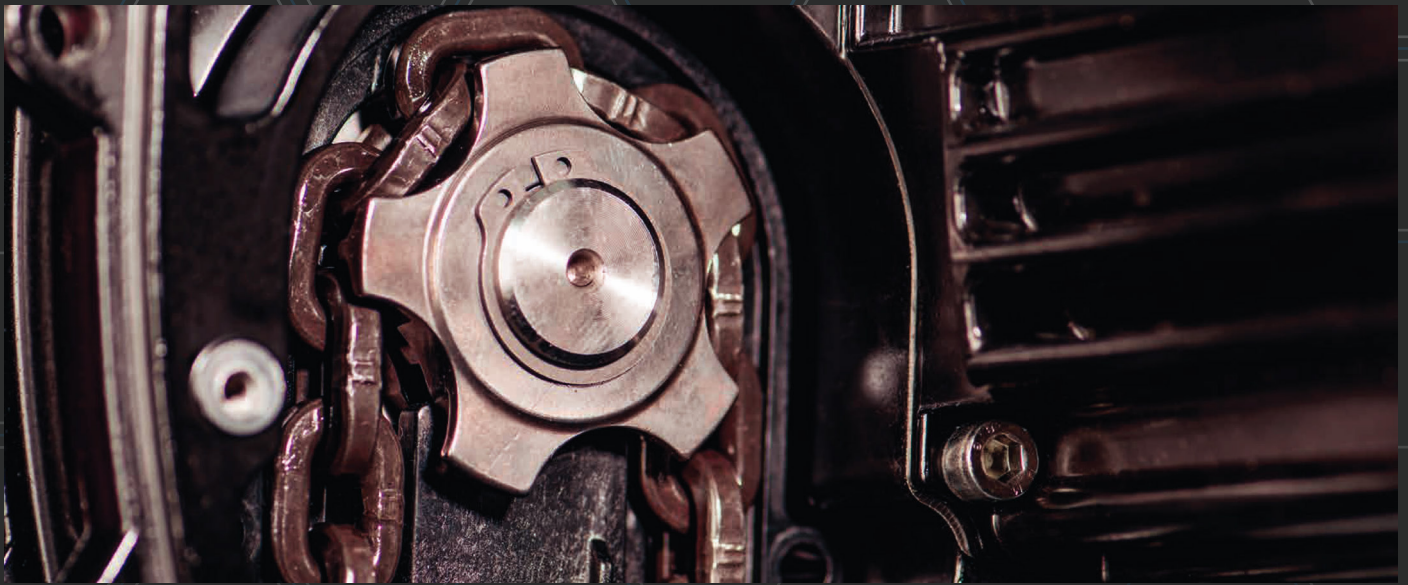

VOYAGER SERVICE

Due to PROTOS's global sales and service network we can provide service to fit or refit your hoist with lengths of lifting chain tailored to meet your exact lifting height requirements. PROTOS is able to equip or upgrade your hoist with double brakes, limit switches and encoders, among other things, locally. Our network offers unique service for inspection, repairs and certification in your country or region guaranteeing fast handling and economic rates. Find your local dealer on protos-one.com.





Document Title	PROTOS VOYAGER Electrical Chain Hoists
Applies To	PROTOS VOYAGER Electrical Chain Hoists
Part Number	2022-001
Issue Number	03.22
Dated	01.03.22

In the interest of continued product development, PROTOS reserves the right to alter product specification without prior notice.

PROTOS B.V.

+31 512 202 004
Ampèrelaan 9
9207 AM Drachten
Netherlands

WWW.PROTOS-ONE.COM

