

SPRING LOADED DEVICES



Ball Plungers.....	104-105
Press Fit Ball Plungers	106
Standard Spring Plungers.....	107
Metric Spring Plungers	108-109
Press Fit Spring Plungers	110
Spring & Ball Wrenches	110
Ball Buttons	110
Posi Hex Plungers.....	111
Hex Nose Plungers	112
Short Spring Plungers.....	113
Shortie Spring Plungers.....	114
Special Plunger Quotation Request Form	115
Hand Retractable.....	116-121
Spring Stops	122
Special Hand Retractable Quotation Request Form	123-124
Installation Information	125
Inch Tap Drill Sizes	125

SPRING LOADED DEVICES



Ball Plungers

- Material:
 - Steel Body: 12L14 Steel
 - Stainless Steel Body: 303 Stainless Steel
 - Ball: 440 Stainless Steel or Nylon
- Smallest and lightest spring loaded device
- Side-load tolerant
- Controlled end forces
- Screwdriver installation
- Many sizes conform to TCMAI standards
- Bodies are color coded to indicate end forces:
 - Plain or Zinc = Light Force
 - Black = Standard Force
 - Gold = Heavy Force

NYLON THREAD LOCKING ELEMENT IS STANDARD ON ALL SIZES
 To order ball plungers without a locking element, simply add an "X" to the end of the part number (ex. 52821X).
 Pricing is the same with or without locking element.

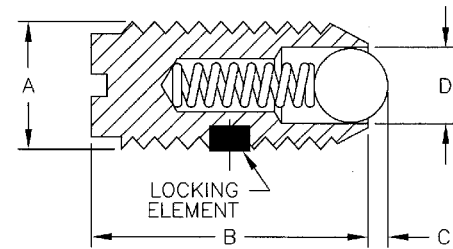

STEEL BODY			STAINLESS STEEL BODY			End Force (lbs)		Thread A	B	C	Ball Dia. D	Weight (lbs/100pcs)
Stainless Steel Ball Part No.	Nylon Ball Part No.	Body Color Type	Stainless Steel Ball Part No.	Nylon Ball Part No.	Body Color Type	Initial	Final					
52821	53821	Black	52901	53830	Plain	.12	.50	4-48	3/16	.020	.062	.005
52822	53822	Black	52902	53831	Plain	.25	.75	5-40	1/4	.020	.062	.02
52823	53823	Black	52903	53832	Plain	.50	1.00	6-40	5/16	.023	.078	.02
52824	53824	Black	52904	53833	Plain	.50	1.25	8-36	11/32	.025	.093	.04
52825	53825	Black	52923	53852	Plain	.50	1.25	8-32	11/32	.025	.093	.04
52801	53801	Zinc	52905	53834	Plain	.50	1.50	10-32	33/64	.025	.093	.30
52802	53802	Black	52906	53835	Black	1.50	3.00	10-32	33/64	.025	.093	.30
52803	53803	Gold	52907	53836	Gold	2.00	5.00	10-32	33/64	.025	.093	.30
52804	53804	Zinc	52908	53837	Plain	2.00	4.00	1/4-20	17/32	.035	.125	.40
52805	53805	Black	52909	53838	Black	3.00	7.00	1/4-20	17/32	.035	.125	.40
52806	53806	Gold	52910	53839	Gold	4.00	12.00	1/4-20	17/32	.035	.125	.40
52807	53807	Zinc	52911	53840	Plain	2.00	4.50	5/16-18	37/64	.040	.156	.70
52808	53808	Black	52912	53841	Black	4.00	9.00	5/16-18	37/64	.040	.156	.70
52809	53809	Gold	52913	53842	Gold	6.00	17.00	5/16-18	37/64	.040	.156	.70
52810	53810	Zinc	52914	53843	Plain	2.50	5.00	3/8-16	5/8	.048	.187	1.20
52811	53811	Black	52915	53844	Black	5.00	10.00	3/8-16	5/8	.048	.187	1.20
52812	53812	Gold	52916	53845	Gold	6.00	21.00	3/8-16	5/8	.048	.187	1.20
52813	53813	Zinc	52917	53846	Plain	3.00	6.00	1/2-13	3/4	.072	.281	2.60
52814	53814	Black	52918	53847	Black	6.00	12.00	1/2-13	3/4	.072	.281	2.60
52815	53815	Gold	52919	53848	Gold	6.00	30.00	1/2-13	3/4	.072	.281	2.60
52816	53816	Zinc	52920	53849	Plain	4.50	9.00	5/8-11	63/64	.096	.375	5.00
52817	53817	Black	52921	53850	Black	9.00	18.00	5/8-11	63/64	.096	.375	5.00
52818	53818	Gold	52922	53851	Gold	7.00	50.00	5/8-11	63/64	.096	.375	5.00

Special sizes quoted upon request – see quotation form on page 115.

For information concerning installation, see page 125.

Metric

STEEL BODY			STAINLESS STEEL BODY			End Force (lbs)		Thread A	B mm (in.)	C mm (in.)	Ball Dia. D mm (in.)
Stainless Steel Ball Part No.	Nylon Ball Part No.	Body Color Type	Stainless Steel Ball Part No.	Nylon Ball Part No.	Body Color Type	Initial	Final				
63901	63961	Black	64001	64061	Black	.90	2.25	M4 x 0.7	9 (.354)	.8 (.032)	2.5 (.098)
63920	-	Black	-	-	-	.50	1.50	M5 x 0.8	13 (.518)	.6 (.023)	2.38 (.093)
63921	-	Black	-	-	-	1.50	3.00	M5 x 0.8	13 (.518)	.6 (.023)	2.38 (.093)
63922	-	Black	-	-	-	2.00	4.90	M5 x 0.8	13 (.518)	.6 (.023)	2.38 (.093)
63902	63962	Black	64002	64062	Black	2.00	2.90	M6 x 1.0	14 (.551)	1 (.039)	3.5 (.138)
63903	63963	Zinc	64003	64063	Plain	.45	1.35	M6 x 1.0	14 (.551)	1 (.039)	3.5 (.138)
63904	63964	Gold	64004	64064	Gold	6.25	8.95	M6 x 1.0	14 (.551)	1 (.039)	3.5 (.138)
63905	63965	Black	64005	64065	Black	3.35	6.70	M8 x 1.25	16 (.630)	1.5 (.059)	5 (.196)
63906	63966	Zinc	64006	64066	Plain	1.11	2.25	M8 x 1.25	16 (.630)	1.5 (.059)	5 (.196)
63907	63967	Gold	64007	64067	Gold	8.95	13.40	M8 x 1.25	16 (.630)	1.5 (.059)	5 (.196)
63908	63968	Black	64008	64068	Black	4.45	7.80	M10 x 1.5	19 (.748)	2 (.079)	6 (.236)
63909	63969	Zinc	64009	64069	Plain	1.80	3.35	M10 x 1.5	19 (.748)	2 (.079)	6 (.236)
63910	63970	Gold	64010	64070	Gold	13.40	20.00	M10 x 1.5	19 (.748)	2 (.079)	6 (.236)
63911	63971	Black	64011	64071	Black	6.70	12.25	M12 x 1.75	22 (.866)	2.5 (.098)	8 (.315)
63912	63972	Zinc	64012	64072	Plain	2.25	4.50	M12 x 1.75	22 (.866)	2.5 (.098)	8 (.315)
63913	63973	Gold	64013	64073	Gold	16.75	25.65	M12 x 1.75	22 (.866)	2.5 (.098)	8 (.315)

Ball Plungers (continued)

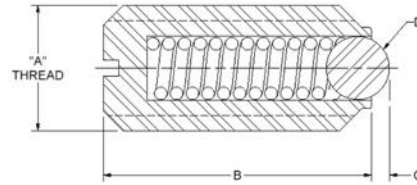

Standard End Pressure – Metric

Steel Part No.	Stainless Steel Part No.	End Force (Newtons)		A	B	C	D
		Initial	Final				
69001X	69101X	1,5	3	M3x0.5	7	0,5	1,5
63901X	64001X	4	10	M4x0.7	9	0,8	2,5
69002X	69102X	6	11	M5x0.8	12	0,9	3
63902X	64002X	9	13	M6x1.0	14	1	3,5
63905X	64005X	15	30	M8x1.25	16	1,5	5
63908X	64008X	20	35	M10x1.5	19	2	6
63911X	64011X	30	55	M12x1.75	22	2,5	8
69003X	69103X	65	125	M16x2.0	24	3,5	10
69004X	69104X	80	160	M20x2.5	30	4,5	12

Heavy End Pressure – Metric

Steel Part No.	Stainless Steel Part No.	End Force (Newtons)		A	B	C	D
		Initial	Final				
69010X	69110X	5	7	M3x0.5	7	0,5	1,5
69011X	69111X	12	22	M4x0.7	9	0,8	2,5
69012X	69112X	19	30	M5x0.8	12	0,9	3
63904X	64004X	28	40	M6x1.0	14	1	3,5
69013X	69113X	47	73	M8x1.25	16	1,5	5
69014X	69114X	66	100	M10x1.5	19	2	6
69015X	69115X	66	120	M12x1.75	22	2,5	8
69016X	69116X	90	180	M16x2.0	24	3,5	10
69017X	69117X	115	240	M20x2.5	30	4,5	12

Available without locking element only



Ball Plungers – Hexagon Socket

- Material:
 - Steel Body: ball in steel, spring steel D
- Surface finish:
 - Steel: black oxide finish
 - Stainless Steel Body: 300 series, ball 400 series, spring 300series

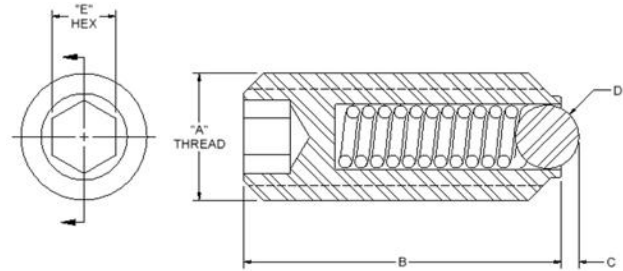

Standard End Pressure – Inch

Steel Part No.	Stainless Steel Part No.	End Force (lbs)		A	B	C	D	E
		Initial	Final					
55001X	55101X	2.0	2.9	1/4-28	15	1	3.5	1/8
55002X	55102X	2.0	2.9	1/4-20	15	1	3.5	1/8
55003X	55103X	3.4	6.7	5/16-18	18	1.5	5	5/32
55004X	55104X	4.5	7.9	3/8-16	23	2	6	3/16
55005X	55105X	6.7	12.4	1/2-13	26	2.5	8	7/32
55006X	55106X	14.6	28.1	5/8-11	33	3.5	10	5/16

Standard End Pressure – Metric

Steel Part No.	Stainless Steel Part No.	End Force (Newtons)		A	D	B	C	E
		Initial	Final					
69201X	69301X	1,5	3	M3x0.5	1,5	9	0,5	1,5
69202X	69302X	4	10	M4x0.7	2,5	10	0,8	2
69203X	69303X	6	11	M5x0.8	3	14	0,9	2,5
69204X	69304X	9	13	M6x1.0	3,5	15	1	3
69205X	69305X	15	30	M8x1.25	5	18	1,5	4
69206X	69306X	20	35	M10x1.5	6	23	2	5
69207X	69307X	30	55	M12x1.75	8	26	2,5	6
69208X	69308X	65	125	M16x2.0	10	33	3,5	8
69209X	69309X	80	160	M20x2.5	12	43	4,5	10
69210X	69310X	90	180	M24x3.0	15	48	5,5	12

Heavy End Pressure – Inch

Steel Part No.	Stainless Steel Part No.	End Force (lbs)		A	D	B	C	E
		Initial	Final					
55010X	55110X	6.3	9.0	1/4-28	15	1	3.5	1/8
55011X	55111X	6.3	9.0	1/4-20	15	1	3.5	1/8
55012X	55112X	10.6	16.4	5/16-18	18	1.5	5	5/32
55013X	55113X	14.8	22.5	3/8-16	23	2	6	3/16
55014X	55114X	14.8	27.0	1/2-13	26	2.5	8	7/32
55015X	55115X	20.2	40.5	5/8-11	33	3.5	10	5/16

Heavy End Pressure – Metric

Steel Part No.	Stainless Steel Part No.	End Force (Newtons)		A	D	B	C	E
		Initial	Final					
69221X	69321X	5	7	M3x0.5	1,5	9	0,5	1,5
69222X	69322X	12	22	M4x0.7	2,5	10	0,8	2
69223X	69323X	19	30	M5x0.8	3	14	0,9	2,5
69224X	69324X	28	40	M6x1.0	3,5	15	1	3
69225X	69325X	47	73	M8x1.25	5	18	1,5	4
69226X	69326X	66	100	M10x1.5	6	23	2	5
69227X	69327X	66	120	M12x1.75	8	26	2,5	6
69228X	69328X	90	180	M16x2.0	10	33	3,5	8
69229X	69329X	115	240	M20x2.5	12	43	4,5	10
69230X	69330X	130	270	M24x3.0	15	48	5,5	12

SPRING LOADED DEVICES



Press Fit Ball Plungers

- Material:
 - Steel Body: 12L14 Steel
 - Stainless Steel Body: 303 Stainless Steel
 - Ball: 440 Stainless Steel
- Black Oxide Finish – Steel Only
- Ideal for installation in softer materials, such as aluminum, wood or plastic
- Sturdy shoulder provides a fixed seating position and positively resists detent force (installation hole can be counterbored to recess the shoulder)
- Use when a threaded hole would be impractical

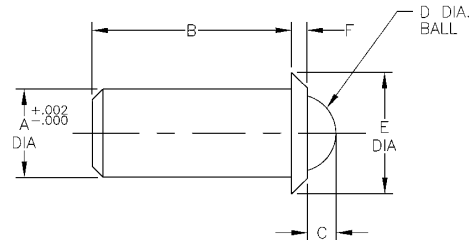

STEEL BODY		STAINLESS BODY		A	End Force (lbs)		B	C	Dia. D	Dia. E	F
Stainless Steel Ball Part No.	Nylon Ball Part No.	Stainless Steel Ball Part No.	Nylon Ball Part No.		Initial	Final					
53754	53762	53755	53780	.125	.4	1.3	.252	.035	.094	.187	.032
53756	53763	53757	53781	.125	.75	2.5	.252	.035	.094	.187	.032
53792	53794	53796	53798	.188	1.0	2.5	.39	.058	.156	.250	.040
53701	53764	53709	53782	.188	1.0	2.5	.410	.058	.156	.250	.035
53702	53766	53710	53784	.250	1.5	3.5	.480	.070	.188	.312	.044
53758	53768	53759	53786	.312	2.0	5.0	.643	.090	.250	.375	.045
53760	53769	53761	53787	.312	4.0	10.0	.643	.090	.250	.375	.045
53703	53770	53711	53788	.375	2.5	7.0	.790	.110	.312	.500	.078
53704	53772	53712	53790	.500	4.0	9.0	1.13	.161	.438	.688	.088
53793	53795	53797	53799	.188	2.0	5.0	.39	.058	.156	.250	.040
53705	53765	53713	53783	.188	2.0	5.0	.410	.058	.156	.250	.035
53706	53767	53714	53785	.250	3.0	7.0	.480	.070	.188	.312	.044
53707	53771	53715	53789	.375	5.0	14.0	.790	.110	.312	.500	.078
53708	53773	53716	53791	.500	8.0	18.0	1.13	.161	.438	.688	.088

Press Fit Ball Plungers – No Flange

- For sensitive and light duty applications
- Black thermoplastic or stainless steel body
- Ball available in plastic, steel and stainless steel



Small and lightweight!

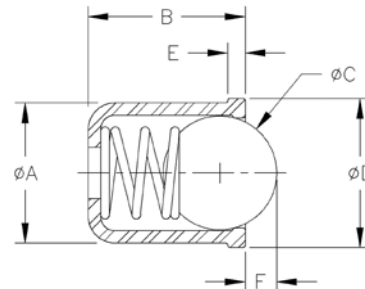

Stainless Steel Body & Ball – Metric

Stainless Steel Part No.	End Force (Newtons)		A	B	Ball Dia. C	D	E	F
	Initial	Final						
53670	3	7	4	5	3	4,6	1	0,8
53671	4	7	5	6	4	5,6	1	1
53672	6	12	6	7	5	6,5	1	1,5
53673	6	12	8	9	6,5	8,5	1	1,8
53674	10	20	10	13,5	8	12	2,5	2,7
53675	15	25	12	16	10	14	2,5	3,5

Plastic Body, Stainless Steel Ball – Metric

Plastic Body Part No.	End Force (Newtons)		A	B	Ball Dia. C	D	E	F
	Initial	Final						
53620	3	7	4	5	3	4,6	1	0,7
53621	4	7	5	6	4	5,6	1	1
53622	6	12	6	7	5	6,5	1	1,5
53623	6	12	8	9	6,5	8,5	1	1,8
53624	10	20	10	13,5	8	12	2,5	2,7
53625	15	25	12	16	10	14	2,5	3,5

Stainless Steel Body, Plastic Ball – Metric

Stainless Steel Part No.	End Force (Newtons)		A	B	Ball Dia. C	D	E	F
	Initial	Final						
53610	3	7	4	5	3	4,6	1	0,5
53611	4	7	5	6	4	5,6	1	0,6
53612	6	12	6	7	5	6,5	1	1,1
53613	6	12	8	9	6,5	8,5	1	1,5
53614	10	20	10	13,5	8	12	2,5	2,3
53615	15	25	12	16	10	14	2,5	3,1

Plastic Body & Ball – Metric

Plastic Body Part No.	End Force (Newtons)		A	B	Ball Dia. C	D	E	F
	Initial	Final						
53616	3	7	4	5	3	4,6	1	0,9
53617	4	7	5	6	4	5,6	1	1,2
53618	6	12	6	7	5	6,5	1	1,5
53619	6	12	8	9	6,5	8,5	1	2
53628	10	20	10	13,5	8	12	2,5	2,7
53629	15	25	12	16	10	14	2,5	3,5

Standard Spring Plungers

- Steel Body Plungers:
 - 12L14 Steel Body, Black
 - Light End Force: Zinc Plated
 - Heavy End Force: Black Oxide Finish
- Stainless Steel Body Plungers:
 - 303 Stainless Steel Body
- Excellent wear resistance

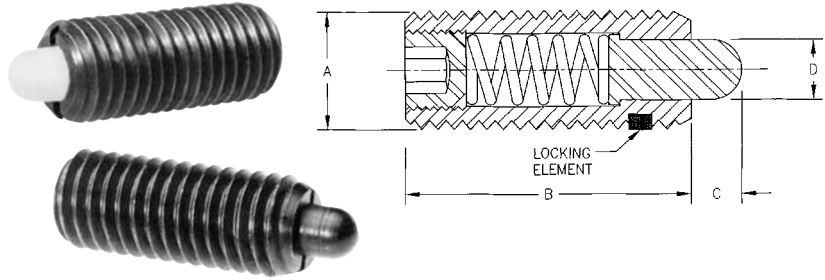

Carbon & Stainless Steel Nose

LIGHT END FORCE				HEAVY END FORCE				Thread A	B	C	+.000 -.001 D	Weight (lbs/100pcs)
Steel Part No.	Stainless Steel Part No.	End Force (lbs)		Steel Part No.	Stainless Steel Part No.	End Force (lbs)						
		Initial	Final			Initial	Final					
–	–			52002	53202	1.00	1.60	6-32	3/8	.062	.046	.10
52201	53301	.50	1.50	52001	53201	1.50	4.50	6-32	17/32	.062	.046	.10
52202	53302	.70	2.30	52003	53203	1.00	1.60	8-32	5/8	.093	.070	.22
52203	53303	1.30	2.70	52004	53204	2.70	7.30	10-32	3/4	.125	.093	.37
52217	53308	.25	2.00	52007	53207	2.90	11.10	1/4-20	3/4	.125	.119	.65
52204	53305	1.00	4.00	52005	53205	3.00	13.00	1/4-20	1	.187	.119	.75
52205	53306	1.00	4.00	52006	53206	3.00	13.00	1/4-28	1	.187	.119	.75
52206	53304	1.50	4.50	52008	53208	2.00	9.00	5/16-18	1	.187	.135	1.40
52207	53307	2.80	7.20	52009	53209	3.00	15.00	3/8-16	1-1/8	.187	.186	2.00
52208	53309	2.70	9.30	52010	53210	5.50	14.50	1/2-13	1-1/4	.250	.248	4.50
52209	53310	3.50	10.50	52011	53211	6.60	17.40	5/8-11	1-1/2	.312	.310	8.00
52210	53311	4.00	16.00	52012	53212	6.70	37.30	3/4-10	1-3/4	.312	.374	14.00
52211	53312	4.00	31.00	52013	53213	16.00	68.00	1-8	2-13/32	.500	.499	32.00

- Nose – Light End Force: Case Hardened 12L14 Steel, Zinc Plated
- Nose – Heavy End Force: Case Hardened 12L14 Steel, Black Oxide Finish

Delrin® Nose

LIGHT END FORCE: WHITE NOSE				HEAVY END FORCE: BLACK NOSE				Thread A	B	C	+.000 -.002 D	Weight (lbs/100pcs)
Steel Part No.	Stainless Steel Part No.	End Force (lbs)		Steel Part No.	Stainless Steel Part No.	End Force (lbs)						
		Initial	Final			Initial	Final					
52301	53313	.70	2.30	52101	53220	2.70	7.30	8-32	5/8	.093	.070	.20
52302	53314	1.30	2.70	52102	53221	2.90	11.10	10-32	3/4	.125	.093	.33
52309	53321	.25	2.00	52109	53228	3.00	13.00	1/4-20	3/4	.125	.119	.65
52303	53315	1.00	4.00	52103	53222	3.00	13.00	1/4-20	1	.187	.119	.70
52308	53320	1.00	4.00	52108	53227	3.00	13.00	1/4-28	1	.187	.119	.70
52304	53316	1.50	4.50	52104	53223	3.00	15.00	5/16-18	1	.187	.135	1.20
52305	53317	2.80	7.20	52105	53224	5.50	14.50	3/8-16	1-1/8	.187	.186	1.80
52306	53318	2.70	9.30	52106	53225	6.60	17.40	1/2-13	1-1/4	.250	.248	3.80
52307	53319	3.50	10.50	52107	53226	10.60	25.50	5/8-11	1-1/2	.312	.310	7.00

- Nose – Light End Force: White Delrin
- Nose – Heavy End Force: Black Delrin

Phenolic Nose

LIGHT END FORCE			HEAVY END FORCE			Thread A	B	C	+.000 -.002 D	Weight (lbs/100pcs)
Steel Part No.	End Force (lbs)		Steel Part No.	End Force (lbs)						
	Initial	Final		Initial	Final					
57409	0.70	2.30	57401	2.70	7.30	8-32	5/8	.093	.070	.20
57410	1.30	2.70	57402	2.90	11.10	10-32	3/4	.125	.092	.33
57411	1.00	4.00	57403	3.00	13.00	1/4-20	1	.187	.118	.70
57412	1.00	4.00	57404	3.00	13.00	1/4-28	1	.187	.118	.70
57413	1.50	4.50	57405	3.00	15.00	5/16-18	1	.187	.135	1.20
57414	2.80	7.20	57406	5.50	14.50	3/8-16	1-1/8	.187	.187	1.80
57415	2.70	9.30	57407	6.60	17.40	1/2-13	1-1/4	.250	.248	3.80
57416	3.50	10.50	57408	10.50	25.50	5/8-11	1-1/2	.312	.310	7.00

- Nose – Brown Phenolic
- Ideal for aluminum, brass, or any soft easily marred material
- High tensile strength

Special sizes quoted upon request – see quotation form on page 115.
For information concerning installation, see page 125.

NYLON THREAD LOCKING ELEMENT IS STANDARD ON ALL SIZES

To order ball plungers without a locking element, simply add an "X" to the end of the part number (ex. 52821X). Pricing is the same with or without locking element.

GENERAL INFORMATION

- Metric sizes available, see page 97
- Many sizes conform to TCMAI standards
- Typical uses: positioning, locating, ejecting, detents, contacts, lifters, insulators, and latches
- Easy installation

Spring Plungers – Pin Style Slotted

- Material:
 - Steel Body: ball in steel, spring steel D
- Surface finish:
 - Steel: black oxide finish
 - Stainless Steel Body: 300 series, ball 400 series, spring 300series

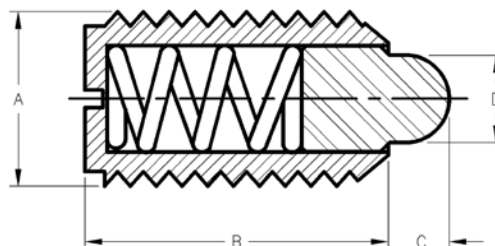

Available without locking element only

Standard End Pressure – Metric

Steel Part No.	Stainless Steel Part No.	End Force (Newtons)		A	B	C	D
		Initial	Final				
69401X	69501X	6	20	M4	9	1,5	1,8
69402X	69502X	6	20	M5	12	2	2,4
69403X	69503X	7	20	M6	14	2	2,7
69404X	69504X	15	30	M8	16	2	4
69405X	69505X	20	35	M10	19	2,5	4,5
69406X	69506X	30	55	M12	22	3,5	6
69407X	69507X	45	100	M16	24	4,5	8,5
69408X	69508X	60	120	M20	30	6,5	10

Light End Pressure – Metric

Steel Part No.	Stainless Steel Part No.	End Force (Newtons)		A	B	C	D
		Initial	Final				
69420X	69520X	3	10	M4	9	1,5	1,8
69421X	69521X	3	10	M5	12	2	2,4
69422X	69522X	4	10	M6	14	2	2,7
69423X	69523X	7	15	M8	16	2	4
69424X	69524X	9	16	M10	19	2,5	4,5
69425X	69525X	14	26	M12	22	3,5	6
69426X	69526X	22	50	M16	24	4,5	8,5
69427X	69527X	30	60	M20	30	6,5	10

Spring Plungers – Hexagon Socket Steel Body

- Material: Steel Body quality class 5.8, pressure pin in steel or plastic, spring in spring steel D
- Finish: Steel with black oxide finish, pressure pin in steel, hardened

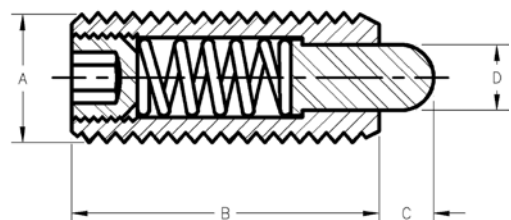

Available without locking element only

Standard End Pressure – Metric

Steel Pin Part No.	Plastic Pin Part No.	End Force (Newtons)		A	B	C	D
		Initial	Final				
69601X	69651X	0,5	3	M3	10	1,5	1
69602X	69652X	5	16	M4	15	1,5	1,5
69603X	69653X	6	20	M5	18	2,3	2,4
63705X	69654X	7	20	M6	20	2,5	2,7
63706X	69655X	9	35	M8	22	3	3,5
63707X	69656X	9	35	M10	22	3	4
63708X	69657X	10	55	M12	28	4	6
69604X	69658X	45	100	M16	32	5	7,5
69605X	-	60	120	M20	40	7	10
69606X	-	80	160	M24	52	10	12

Heavy End Pressure – Metric

Steel Pin Part No.	End Force (Newtons)		A	B	C	D
	Initial	Final				
69620X	11	29	M5	18	2,3	2,4
69621X	14	37	M6	20	2,5	2,7
69622X	22	65	M8	22	3	3,5
69623X	19	70	M10	22	3	4
69624X	25	85	M12	28	4	6
69625X	60	150	M16	32	5	7,5
69626X	75	190	M20	40	7	10
69627X	95	240	M24	52	10	12

Light End Pressure – Metric

Steel Pin Part No.	Plastic Pin Part No.	End Force (Newtons)		A	B	C	D
		Initial	Final				
69610X	69660X	2	7	M4	15	1,5	1,5
69611X	69661X	3	10	M5	18	2,3	2,4
69612X	69662X	3	9	M6	20	2,5	2,7
69613X	69663X	4	16	M8	22	3	3,5
69614X	69664X	4	16	M10	22	3	4
69615X	69665X	5	27	M12	28	4	6
69616X	69666X	20	45	M16	32	5	7,5

Spring Plungers – Hexagon Socket Stainless Steel Body

- Material: Body 1.4305, pressure pin 1.4034 or plastic, spring 1.4310
- Finish: Stainless steel body with natural finish, pressure pin in stainless steel, hardened



Available without
locking element only

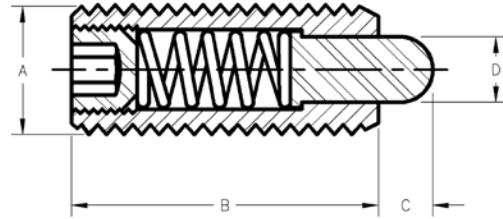

Standard End Pressure – Metric

Stainless Pin Part No.	Plastic Pin Part No.	End Force (Newtons)		A	B	C	D
		Initial	Final				
69701X	69751X	0,5	3	M3	10	1,5	1
69702X	69752X	5	16	M4	15	1,5	1,5
69703X	69753X	5	17	M5	18	2,3	2,4
69704X	69754X	6	17	M6	20	2,5	2,7
69705X	69755X	7	29	M8	22	3	3,5
69706X	69756X	8	31	M10	22	3	4
69707X	69757X	10	47	M12	28	4	6
69608X	69758X	45	100	M16	32	5	7,5

Heavy End Pressure – Metric

Stainless Pin Part No.	End Force (Newtons)		A	B	C	D
	Initial	Final				
69801X	9	26	M5	18	2,3	2,4
69802X	11	35	M6	20	2,5	2,7
69803X	15	48	M8	22	3	3,5
69804X	15	58	M10	22	3	4
69805X	19	74	M12	28	4	6

Metric Spring Plungers

- Material:
 - Steel Body: 12L14 Steel, Black Oxide Finish
 - Stainless Steel Body: 303 Stainless Steel
 - Steel Nose: 12L14 Steel, Black Oxide Finish
 - Stainless Steel Nose: 303 Stainless Steel
- Many sizes conform to TCMAI standards
- All dimensions in metric format

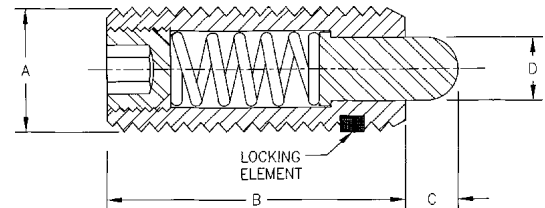

Steel Part No.	Stainless Steel Part No.	End Force (Newtons)		Thread A	B mm (in.)	C mm (in.)	+0.00/-0.025 D mm (in.)
		Initial	Final				
63701	63720	4.00	11.15	M6 x 1.0	20 (.787)	2.5 (.098)	2.7 (.106)
63702	63721	5.60	15.60	M8 x 1.25	22 (.866)	3 (.118)	3.5 (.138)
63703	63722	5.60	15.60	M10 x 1.50	22 (.866)	3 (.118)	4 (.157)
63704	63723	10.00	24.50	M12 x 1.75	28 (1.102)	4 (.157)	6 (.236)
63705	63724	1.60	4.50	M6 x 1.0	20 (.787)	2.5 (.098)	2.7 (.106)
63706	63725	2.00	7.80	M8 x 1.25	22 (.866)	3 (.118)	3.5 (.138)
63707	63726	2.00	7.80	M10 x 1.50	22 (.866)	3 (.118)	4 (.157)
63708	63727	2.25	12.30	M12 x 1.75	28 (1.102)	4 (.157)	6 (.236)

NYLON THREAD LOCKING ELEMENT IS STANDARD ON ALL SIZES

To order ball plungers without a locking element, simply add an "X" to the end of the part number (ex. 52821X). Pricing is the same with or without locking element.

SPRING LOADED DEVICES



Press Fit Spring Plungers

- Material:
 - Steel Body: 12L14 Steel
 - Stainless Steel Body: 303 Stainless Steel
 - Steel Plunger: 12L14 Steel
 - Stainless Steel Plunger: 303 Stainless Steel
- Ideal for installation in softer materials such as aluminum, wood, or plastic
- Withstands high temperatures
- No thread adjustment
- Longer travel

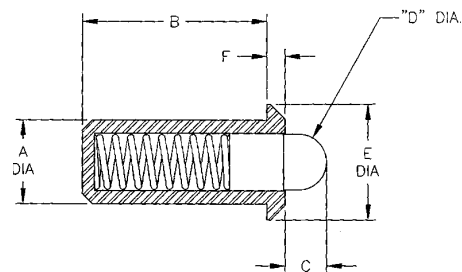

Steel Part No.	Stainless Steel Part No.	End Force (lbs)*		+.002 -.000 A	B	C	D	E	F
		Initial	Final						
53601	53650	.75	2.00	.188	.441	.094	.121	.250	.044
53602	53651	1.25	3.00	.250	.521	.125	.168	.312	.055
53603	53652	2.50	7.00	.375	.788	.187	.234	.500	.096
53604	53653	4.00	9.00	.500	1.100	.250	.332	.688	.134
53605	53654	1.50	4.50	.188	.441	.094	.121	.250	.044
53606	53655	2.50	6.00	.250	.521	.125	.168	.312	.055
53607	53656	5.00	14.00	.375	.788	.187	.234	.500	.096
53608	53657	5.00	18.00	.500	1.100	.250	.332	.688	.134

Spring and Ball Plunger Wrenches

Designed to eliminate excessive spring compression during installation and removal of spring and ball plungers.

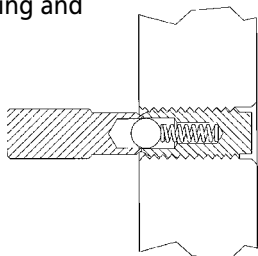

Part No.	Fits Following Spring and Ball Plunger Sizes		Weight (lbs/100pcs)
	Inches	MM	
53001	6-32	–	1
53002	8-32	M4	1
53003	10-32	M5	1
53004	1/4-20	M6	1.5
53005	5/16-18	M8	3
53006	3/8-16	M10	3
53007	1/2-13	M12	5
53008	5/8-11	–	9
53009	3/4-10	–	13
53010	1-8	–	19

Stainless Steel Ball Buttons

The ideal mating detent for ball plungers or other similar applications. Hardened and ground 440C stainless steel.

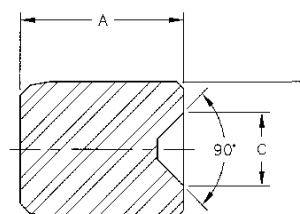

Part No.	For use with Ball Dia.	A	+.0002 -.0000	
			B	C
57501	.0620	1/8	.1075	.056
57502	.0780	1/8	.1175	.051
57503	.0938	3/16	.1614	.069
57504	.1250	1/4	.2034	.111
57505	.1560	5/16	.2559	.139
57506	.1875	3/8	.3284	.164
57507	.2813	1/2	.4378	.241
57508	.3750	5/8	.5472	.330

Posi Hex Plungers

- Material:
 - Steel Body: 12L14 Steel
 - Stainless Steel Body: 303 Stainless Steel
 - Steel Plunger: 12L14 Steel, Case Hardened
 - Stainless Steel Plunger: 303 Stainless Steel
- Heavy End Force: Black Oxide Finish
- Light End Force: Zinc Plated Nose
- Easy installation and removal
- Withstands high torque
- One-piece body – no set screw in back

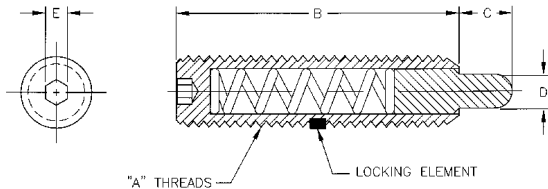

METRIC

Heavy End Force

STEEL BODY		End Force (lbs)		Thread A	B	C	D*	E
Steel Nose Part No.	Blue Delrin Nose Part No.	Initial	Final					
67001	67080	2.70	7.30	M4 x 0.7	16	2.5	1.78	2
67002	67081	2.90	11.10	M5 x 0.8	19	3.0	2.36	2.5
67003	67082	3.00	13.00	M6 x 1.0	25	5.0	3.02	3
67004	67083	3.00	15.00	M8 x 1.25	25	5.0	3.43	4
67005	67084	5.50	14.50	M10 x 1.5	29	5.0	4.72	5
67006	67085	6.60	17.40	M12 x 1.75	32	6.0	6.30	6
67007	67086	10.50	25.50	M16 x 2.0	38	8.0	7.87	8
67008	67087	6.70	37.30	M20 x 2.5	44	8.0	9.50	10

Light End Force

STEEL BODY		End Force (lbs)		Thread A	B	C	D*	E
Steel Nose Part No.	White Delrin Nose Part No.	Initial	Final					
67009	67088	.70	2.30	M4 x 0.7	16	2.5	1.78	2
67010	67089	1.30	2.70	M5 x 0.8	19	3.0	2.36	2.5
67011	67090	1.00	4.00	M6 x 1.0	25	5.0	3.02	3
67012	67091	1.50	4.50	M8 x 1.25	25	5.0	3.43	4
67013	67092	2.80	7.20	M10 x 1.5	29	5.0	4.72	5
67014	67093	2.70	9.30	M12 x 1.75	32	6.0	6.30	6
67015	67094	3.50	10.50	M16 x 2.0	38	8.0	7.87	8
67016	67095	4.00	16.00	M20 x 2.5	44	8.0	9.50	10

ENGLISH

Heavy End Force

STEEL BODY		STAINLESS BODY		End Force (lbs)		Thread A	B	C	D*	E
Steel Nose Part No.	Blue Delrin Nose Part No.	Stainless Nose Part No.	Initial	Final						
57001	57085	57015	1.5	4.5	6-32	17/32	1/16	.045	1/16	
57002	-	57016	1.0	1.6	6-32	1/2	1/16	.045	1/16	
57003	57086	57017	2.7	7.3	8-32	5/8	3/32	.070	1/16	
57004	57087	57018	2.9	11.1	10-32	3/4	1/8	.092	1/16	
57005	57088	57019	3.0	13.0	1/4-20	1	3/16	.118	5/64	
57006	57089	57020	3.0	13.0	1/4-28	1	3/16	.118	5/64	
57007	-	57021	2.0	9.0	1/4-20	3/4	1/8	.118	5/64	
57008	57090	57022	3.0	15.0	5/16-18	1	3/16	.135	3/32	
57080	57091	-	5.5	14.5	3/8-16	1-1/8	3/16	.186	3/16	
57081	57092	-	6.6	17.4	1/2-13	1-1/4	1/4	.248	1/4	
57082	57093	-	10.5	25.5	5/8-11	1-1/2	5/16	.310	5/16	
57083	-	-	6.7	37.3	3/4-10	1-3/4	5/16	.374	3/8	



Light End Force

STEEL BODY		STAINLESS BODY		End Force (lbs)		Thread A	B	C	D*	E
Steel Nose Part No.	White Delrin Nose Part No.	Stainless Nose Part No.	Initial	Final						
57009	57185	57023	0.5	1.5	6-32	17/32	1/16	.045	1/16	
57010	57186	57024	0.7	2.3	8-32	5/8	3/32	.070	1/16	
57011	57187	57025	1.3	2.7	10-32	3/4	1/8	.092	1/16	
57012	57188	57026	1.0	4.0	1/4-20	1	3/16	.118	5/64	
57013	57189	57027	1.0	4.0	1/4-28	1	3/16	.118	5/64	
57014	57190	57028	1.5	4.5	5/16-18	1	3/16	.135	3/32	
57180	57191	-	2.8	7.2	3/8-16	1-1/8	3/16	.186	3/16	
57181	57192	-	2.7	9.3	1/2-13	1-1/4	1/4	.248	1/4	
57182	57193	-	3.5	10.5	5/8-11	1-1/2	5/16	.310	5/16	
57183	-	-	5.5	14.5	3/4-10	1-3/4	5/16	.374	3/8	
57184**	-	-	10.0	25.0	1-8	2-13/32	1/2	.499	3/8	

* INCH SIZES

Steel Nose: +.000, -.001
 Delrin Nose: +.000, -.002

* METRIC SIZES

Steel Nose: +.000, -.025
 Delrin Nose: +.000, -.050

**Not available in one-piece design

SPRING LOADED DEVICES



Flat Hex Nose Plungers

- Material: Steel, Black Oxide Finish
- Ideal for tough, high-speed, long-life product applications
- Flat, hexagonal nose design
- Easy access and adjustment
- Long spring life

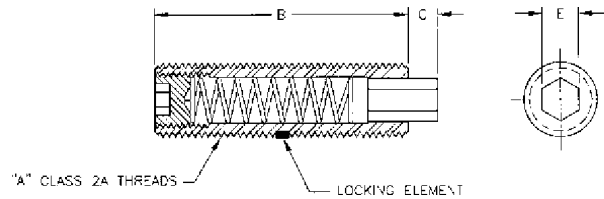

Part No.	End Force (lbs)		Thread A	B	C	E
	Initial	Final				
57301	0.50	6-1/8	1/4-20	1.343	.078	1/8
57302	0.50	8	5/16-18	1.406	.088	1/8
57303	0.50	9-7/8	3/8-16	1.532	.097	3/16
57304	0.50	16	1/2-13	1.718	.105	1/4

Long Travel Hex Nose Plungers

- Material: Steel
- Ideal for high-speed, long-life applications
- Hexagonal nose design
- Easy insertion, adjustment or removal

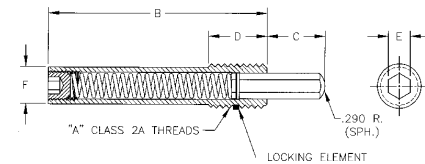

Body & Nose: Black Oxide Finish
Heavy End Force

Part No.	End Force (lbs)		Thread A	B	C	D	E	F
	Initial	Final						
57101	4.0	20.0	5/8-11	3.12	1.00	1.25	.31	.510
57102	4.0	35.0	3/4-10	3.75	1.00	1.50	.38	.623
57103	16	50-3/4	1-8	5.00	1.00	2.00	.50	.844
57104	16	68	1-8	5.00	1.50	2.00	.50	.844

Body: Black Oxide Finish/Nose: Zinc Plated
Light End Force

Part No.	End Force (lbs)		Thread A	B	C	D	E	F
	Initial	Final						
57105	4.0	22	1-8	5	1.00	2.00	.50	.844
57106	4.0	31	1-8	5	1.00	2.00	.50	.844

Hex Nose Plungers

- Material: Steel, Black Oxide Finish
- Case hardened plunger
- Heavy End Force: Black Oxide Finish
- Light End Force: Zinc Plated Nose
- Hexagonal nose design allows for easy installation/removal with socket wrench

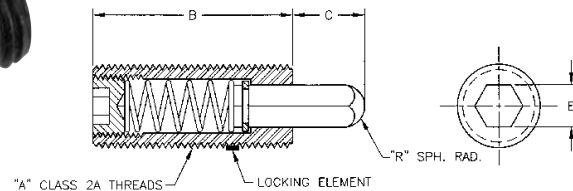

Heavy End Force

Part No.	End Force (lbs)		Thread A	B	C	E	R
	Initial	Final					
57201	3.0	13.0	1/4-20	1	3/16	1/8	.071
57202	3.0	15.0	5/16-18	1	3/16	1/8	.071
57203	5.5	14.5	3/8-16	1-1/8	3/16	3/16	.108
57204	6.6	17.4	1/2-13	1-1/4	1/4	1/4	.144
57205	10.5	25.5	5/8-11	1-1/2	5/16	5/16	.179
57206	6.7	37.3	3/4-10	1-3/4	5/16	3/8	.215
57207	16.0	68.0	1-8	2-13/32	1/2	1/2	.290

Light End Force

Part No.	End Force (lbs)		Thread A	B	C	E	R
	Initial	Final					
57210	1.0	4.0	1/4-20	1	3/16	1/8	.071
57211	1.5	4.5	5/16-18	1	3/16	1/8	.071
57212	2.8	7.2	3/8-16	1-1/8	3/16	3/16	.108
57213	2.7	9.3	1/2-13	1-1/4	1/4	1/4	.144
57214	3.5	10.5	5/8-11	1-1/2	5/16	5/16	.179
57215	4.0	31.0	1-8	2-13/32	1/2	1/2	.290

Short Spring Plungers –Light and Heavy End Forces

Carbon & Stainless Steel Nose

- Excellent wear resistance

STEEL PLUNGERS:

- Body: 12L14 Steel, Black Oxide Finish
- Nose:
 - Light End Force: Case Hardened 12L14 Steel, Zinc Plated
 - Heavy End Force: Case Hardened 12L14 Steel, Black Oxide Finish



STAINLESS STEEL PLUNGERS:

- 303 Stainless Steel Body and Nose

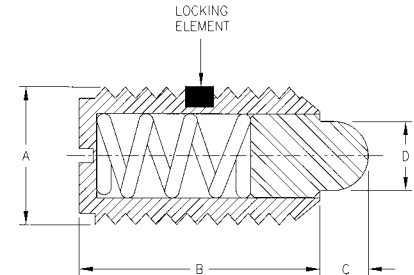

LIGHT END FORCE				HEAVY END FORCE				Thread A	B	C	+.000 -.001 D	Weight (lbs/100pcs)
Steel Part No.	Stainless Steel Part No.	End Force (lbs)		Steel Part No.	Stainless Steel Part No.	End Force (lbs)						
		Initial	Final			Initial	Final					
52608	53508	.50	1.50	52408	53408	.50	3.50	6-32	3/8	.036	.046	.12
52609	53509	.50	1.50	52409	53409	1.50	4.75	8-32	7/16	.052	.070	.12
52601	53501	.50	1.50	52401	53401	1.50	4.75	8-36	7/16	.052	.069	.15
52602	53502	.75	2.50	52402	53402	1.75	6.25	10-32	15/32	.065	.093	.16
52603	53503	1.00	3.50	52403	53403	3.00	10.50	1/4-20	17/32	.078	.119	.40
52604	53504	1.50	4.00	52404	53404	3.75	15.50	5/16-18	9/16	.084	.135	.60
52605	53505	1.50	5.00	52405	53405	4.50	18.50	3/8-16	5/8	.110	.186	.90
52606	53506	1.75	5.50	52406	53406	5.00	28.00	1/2-13	3/4	.151	.248	2.50
52607	53507	2.00	8.50	52407	53407	7.00	50.00	5/8-11	1-1/16	.215	.310	6.00

*Special sizes quoted upon request – see quotation form on page 115.
For information concerning installation, see page 125.*

Delrin® Nose

- Insulating Delrin Plungers
- Ideal for aluminum, brass, or any soft, easily marred mating material



STEEL PLUNGERS:

- Body: 12L14 Steel, Clear Zinc Finish
- Nose:
 - Light End Force: White Delrin
 - Heavy End Force: Black Delrin

STAINLESS STEEL PLUNGERS:

- Body: 303 Stainless Steel
- Nose:
 - Light End Force: White Delrin
 - Heavy End Force: Black Delrin

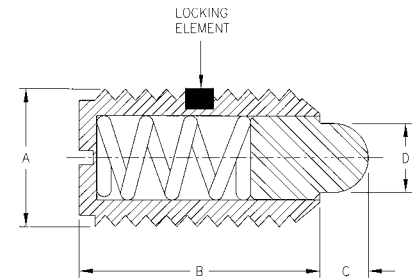

LIGHT END FORCE: WHITE NOSE				HEAVY END FORCE: BLACK NOSE				Thread A	B	C	+.000 -.002 D	Weight (lbs/100pcs)
Steel Part No.	Stainless Steel Part No.	End Force (lbs)		Steel Part No.	Stainless Steel Part No.	End Force (lbs)						
		Initial	Final			Initial	Final					
52708	53527	0.50	1.50	52508	53427	0.50	3.50	6-32	3/8	.036	.046	.12
52709	53528	0.50	1.50	52509	53428	1.50	4.75	8-32	7/16	.052	.070	.12
52701	53520	0.50	1.50	52501	53420	1.50	4.75	8-36	7/16	.052	.070	.12
52702	53521	0.75	2.50	52502	53421	1.75	6.25	10-32	15/32	.065	.093	.16
52703	53522	1.00	3.50	52503	53422	3.00	10.50	1/4-20	17/32	.078	.119	.40
52704	53523	1.50	4.00	52504	53423	3.75	15.50	5/16-18	9/16	.084	.135	.60
52705	53524	1.50	5.00	52505	53424	4.50	18.50	3/8-16	5/8	.110	.186	.90
52706	53525	1.75	5.50	52506	53425	5.00	28.00	1/2-13	3/4	.151	.248	2.00
52707	53526	2.00	8.50	52507	53426	7.00	50.00	5/8-11	1-1/16	.215	.310	4.60

SPRING LOADED DEVICES



Shortie Spring Plungers – Long Travel

– Light and Heavy End Forces

- Shortie spring plungers offer a longer nose than our standard short spring plungers
- All Long Travel Shortie Spring Plungers have a nylon patch



STEEL NOSE/STEEL BODY SHORTIES:

- Steel nose offers excellent wear resistance
- Body: Low Carbon Steel, Black Oxide Finish
- Nose:
 - Light End Force: Zinc Plated Clear Chromate
 - Heavy End Force: Black Oxide Finish

DELRIN® NOSE/STEEL BODY SHORTIES:

- Delrin nose is ideal for aluminum, brass, or any soft, easily marred material
- Body: Low Carbon Steel, Black Oxide Finish
- Nose:
 - Light End Force: White Delrin
 - Heavy End Force: Blue Delrin

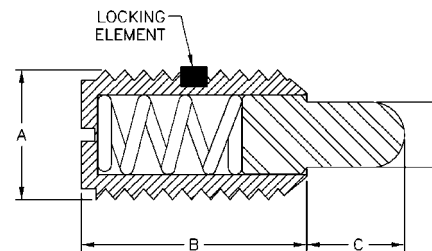

English

LIGHT END FORCE				HEAVY END FORCE				Thread	A	B	C	D
Steel Part No.	White Delrin Nose Part No.	End Force (lbs)		Steel Part No.	Blue Delrin Nose Part No.	End Force (lbs)						
		Initial	Final			Initial	Final					
52610	52618	.50	1.50	52410	52418	.50	3.50	6-32	3/8	1/16	.046	
52611	52619	.50	2.00	52411	52419	.50	4.00	8-32	1/2	3/32	.070	
52612	52620	.50	3.00	52412	52420	.50	5.00	10-32	9/16	1/8	.093	
52613	52621	.50	3.50	52413	52421	.50	6.00	1/4-20	5/8	3/16	.119	
52614	52622	.50	4.50	52414	52422	.50	10.00	5/16-18	5/8	3/16	.135	
52615	52623	1.00	7.50	52415	52423	1.00	12.00	3/8-16	11/16	3/16	.186	
52616	52624	2.50	8.50	52416	52424	2.50	15.00	1/2-13	13/16	1/4	.248	
52617	52625	3.50	10.50	52417	52425	3.50	26.00	5/8-11	1-1/8	5/16	.310	

Metric

LIGHT END FORCE				HEAVY END FORCE				Thread	A	B	C	+.000 -.025 D	Wt. (lbs/ 100pcs)
Steel Part No.	White Delrin Nose Part No.	End Force (lbs)		Steel Part No.	Blue Delrin Nose Part No.	End Force (lbs)							
		Initial	Final			Initial	Final						
64108	64122	.50	2.00	64101	64115	.50	4.00	M4 x 0.7	13.0	2.5	1.78	.12	
64109	64123	.30	3.00	64102	64116	.50	5.00	M5 x 0.8	14.5	3.0	2.36	.16	
64110	64124	.30	3.50	64103	64117	.50	6.00	M6 x 1.0	16.0	4.0	3.02	.40	
64111	64125	.50	4.50	64104	64118	.50	10.00	M8 x 1.25	16.0	5.0	3.43	.60	
64112	64126	1.50	7.45	64105	64119	1.00	12.00	M10 x 1.5	17.5	5.5	4.72	.90	
64113	64127	1.70	8.45	64106	64120	2.50	14.90	M12 x 1.75	20.5	6.5	6.30	2.50	
64114	64128	2.00	10.40	64107	64121	3.50	25.80	M16 x 2.0	28.5	8.0	7.87	6.00	

Metric Plungers dimensioned in millimeters unless otherwise noted

*Special sizes quoted upon request – see quotation form on page 105.
For information concerning installation, see page 115.*



SPRING LOADED DEVICES

Special Plunger Quotation Request Form

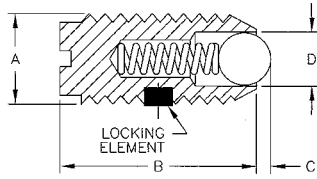

Ball Plunger

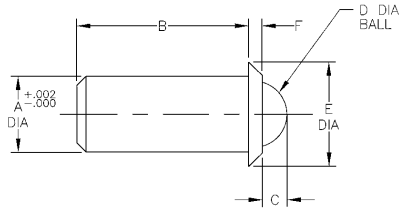

Press Fit Ball Plunger

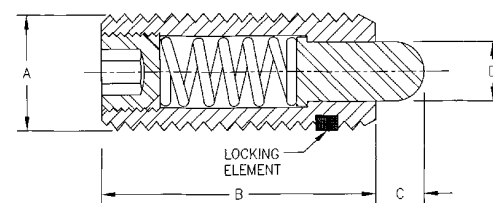

Spring Plunger

Dimension Information:

Thread "A" _____

Body Length "B" _____

Nose Length "C" _____

Nose Diameter "D" _____

Collar Diameter "E" _____ (Press Fit Ball Plunger Only)

Collar Height "F" _____ (Press Fit Ball Plunger Only)

Type Plunger: Ball _____ Press Fit Ball _____ Spring _____ Other _____

Application _____

Thread O.D. _____ (Class 2A)

Plunger Travel Distance: _____

Initial Force: _____ Final Force: _____

Locking Element: Yes _____ No _____ (Thread sizes 1/4" and smaller receive a nylon patch, all others receive a nylon pellet.)

Nose/Ball Material: _____ Nose/Ball Finish: _____

Body Material: _____ Body Finish: _____

Spring Material: _____

Applicable Environmental Conditions (Temperature Range, Chemical, Corrosives, Etc.)

Quantity: _____ Required Delivery: _____

Name _____

Company _____

Phone _____

Fax _____

Please photocopy this page as needed for quotation purposes

SPRING LOADED DEVICES



Hand Retractable Spring Plunger Quick Release "Pull Ring" Steel & Stainless Steel: Locking

- Designed for applications where space is limited
- Plunger can be completely withdrawn into the body and locked into a retracted position
- Chamfered plunger for easy alignment

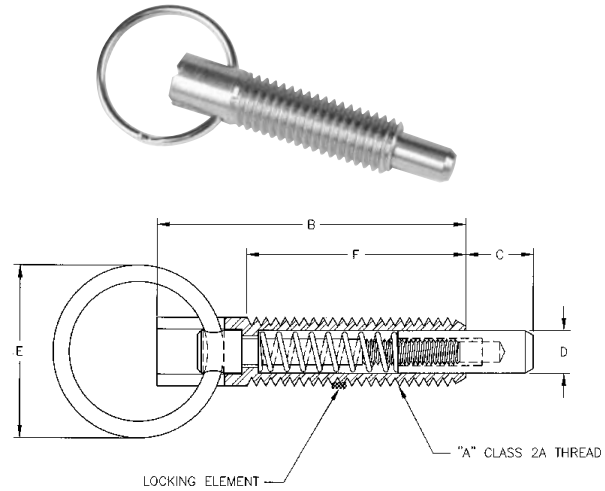

Steel* Black Part No.	Steel** Clear Part No.	Stainless Steel Part No.	End Force (lbs)		Thread A	B	C	D	E	F	Weight (lbs/100pcs)
			Initial	Final							
54401	54414	54405	1.00	2.50	1/4-20	1.14	0.250	0.155	.62	.8	2
54402	54415	54406	2.00	4.00	3/8-16	1.68	0.375	0.233	.98	1.2	4
54403	54416	54407	2.50	5.00	1/2-13	2.00	0.500	0.312	1.26	1.4	9

*Black Oxide Finish **Zinc Plated Clear Chromate Finish

Stubby Hand Retractable Spring Plunger Quick Release "Pull Ring" Steel & Stainless Steel: Non-Locking

- Designed for applications where space is limited
- Chamfered plunger for easy alignment
- Withstands side loading

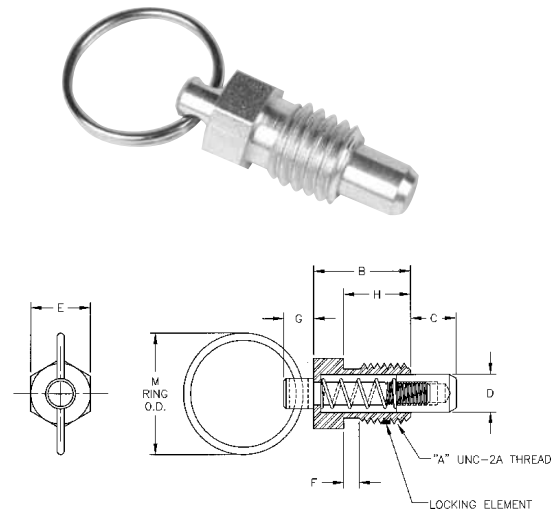

Steel** Part No.	Stainless Steel Part No.	End Force (lbs)		Thread A	B	C	D	Hex E	F	G	H	M
		Initial	Final									
54450	54455	.50	2.0	1/4-20	.44	.19	.16	.25	*	.18	.31	.62
54451	54456	.50	2.0	1/4-20	.44	.19	.16	.25	*	.18	.31	.75
54452	54457	.75	3.0	3/8-16	.63	.28	.25	.38	.13	.19	.44	.75
54453	54458	1.0	4.0	1/2-13	.81	.38	.31	.50	.13	.25	.56	1.0
54454	54459	1.25	5.0	5/8-11	1.0	.44	.38	.62	.13	.31	.69	1.0

*No thread relief **Zinc Plated Clear Chromate Finish

Delrin® Knob Hand Retractable Spring Plungers Steel & Stainless Steel: Non-Locking

- Contoured knob
- Unified ANSI & metric threads

DELTRIN KNOB / STEEL BODY:

- Body: Steel
- Nose: Case Hardened Steel
- Knob: Black Delrin

DELTRIN KNOB / STAINLESS STEEL BODY:

- Body: Stainless Steel
- Nose: Stainless Steel
- Knob: White Delrin
- Ideal for food and medical applications

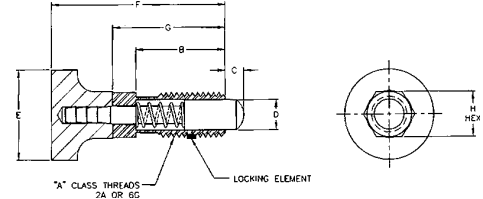

English

Steel Part No.	Stainless Steel Part No.	End Force (lbs)		Thread				E	F	G	Hex H
		Initial	Final	A	B	C	D				
58350*	58450*	.12	.36	1/4-20	.50	.13	.16	.50	.97	.63	1/4
58351	58451	.25	2.0	3/8-16	.75	.18	.25	.75	1.4	.94	3/8
58352	58452	.50	1.75	1/2-13	1.0	.25	.31	1.0	1.9	1.25	1/2

*No thread relief in 1/4-20 thread size
Initial End Forces = +/-50% Final End Forces = +/-25%

Metric

Steel Part No.	Stainless Steel Part No.	End Force (lbs)		Thread A mm (in.)	B mm (in.)	C mm (in.)	D mm (in.)	E mm (in.)	F mm (in.)	G mm (in.)	Hex H mm (in.)
		Initial	Final								
68350*	68450*	.11	.34	M6 x 1.0	13 (.50)	3 (.118)	3 (.117)	12 (.48)	25 (.98)	16 (.63)	6 (.236)
68351	68451	.22	2.02	M10 x 1.5	20 (.79)	5 (.196)	6 (.236)	19 (.75)	38 (1.5)	25 (.98)	10 (.39)
68352	68452	.56	1.80	M12 x 1.75	25 (.98)	6 (.236)	8 (.314)	25 (.98)	47 (1.85)	31 (1.2)	12(.472)

*No thread relief in M6 thread size

Delrin® Knob Hand Retractable Spring Plungers Steel & Stainless Steel: Locking

- Contoured knob
- Unified ANSI & metric threads

DELTRIN KNOB / STEEL BODY:

- Body: Steel
- Nose: Case Hardened Steel
- Knob: Black Delrin

DELTRIN KNOB / STAINLESS STEEL BODY:

- Body: Stainless Steel
- Nose: Stainless Steel
- Knob: White Delrin
- Ideal for food and medical applications

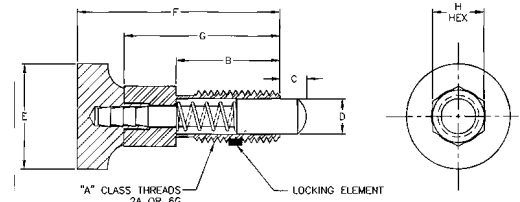

English

Steel Part No.	Stainless Steel Part No.	End Force (lbs)		Thread				E	F	G	Hex H
		Initial	Final	A	B	C	D				
58301*	58401*	.12	.36	1/4-20	.50	.13	.16	.50	.97	.75	1/4
58302	58402	.25	2.0	3/8-16	.75	.18	.25	.75	1.4	1.13	3/8
58303	58403	.50	1.75	1/2-13	1.0	.25	.31	1.0	1.9	1.50	1/2

*No thread relief in 1/4-20 thread size
Initial End Forces = +/-50% Final End Forces = +/-25%

Metric

Steel Part No.	Stainless Steel Part No.	End Force (lbs)		Thread A mm (in.)	B mm (in.)	C mm (in.)	D mm (in.)	E mm (in.)	F mm (in.)	G mm (in.)	Hex H mm (in.)
		Initial	Final								
68301*	68401*	.11	.34	M6 x 1.0	13 (.50)	3 (.118)	3 (.117)	12 (.48)	25 (.98)	19	6 (.236)
68302	68402	.22	2.02	M10 x 1.5	20 (.79)	5 (.196)	6 (.236)	19 (.75)	38 (1.5)	30	10 (.39)
68303	68403	.56	1.80	M12 x 1.75	25 (.98)	6 (.236)	8 (.314)	25 (.98)	47 (1.85)	37	12(.472)

*No thread relief in M6 thread size

SPRING LOADED DEVICES



Knurled Knob Hand Retractable Spring Plungers Steel & Stainless Steel: Non-Locking

- Material:
 - Body: Steel or Stainless Steel
 - Plunger: Steel or Stainless Steel
- Unified ANSI and metric threads
- Hand retractable plunger can be easily engaged and withdrawn
- Chamfered plunger for easy alignment
- Built-in drive wrench for rapid installation and alignment

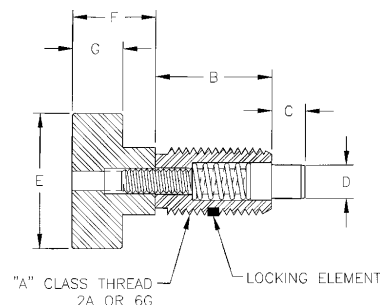

Steel* Black Part No.	Steel** Yellow Part No.	Stainless Steel Part No.	End Force (lbs)		Thread A	B	C	+.001 -.001 D	E	F	G	Weight (lbs/100pcs)
			Initial	Final								
–	54654	54505	.50	3.0	10-32	.400	.094	.104***	0.38	.250	.190	2
54601	54650	54501	1.00	4.00	1/4-20	.500	.125	.123	0.50	.313	.190	2
54602	54651	54502	1.00	6.00	5/16-18	.625	.188	.154	0.63	.375	.250	4
54603	54652	54503	1.00	8.00	3/8-16	.750	.218	.185	0.75	.500	.310	6
54604	54653	54504	1.00	10.00	1/2-13	.875	.250	.248	1.00	.625	.380	8

*Black Oxide Finish **Zinc Plated Yellow Chromate Finish ***Radiused Nose

METRIC

Steel** Part No.	Stainless Steel Part No.	End Force (lbs)		Thread A	B mm (in.)	C mm (in.)	D* mm (in.)	E mm (in.)	F mm (in.)	G mm (in.)
		Initial	Final							
64601	64501	0.5	3.0	M5 x 0.8	10 (.394)	2 (.078)	2.5 (.0984)	9(.355)	6 (.236)	4 (.157)
64602	64502	1.0	4.0	M6 x 1.0	13 (.512)	3 (.118)	3 (.118)	13 (.512)	8 (.315)	5 (.197)
64603	64503	1.0	8.0	M10 x 1.5	19 (.748)	6 (.236)	5 (.1968)	19 (.748)	13 (.512)	8 (.315)
64604	64504	1.0	10.0	M12 x 1.75	23 (.905)	6 (.236)	6 (.236)	25 (.984)	16 (.630)	10 (.315)

*Tolerance: +.000; -.0254 (+.000; -.001) **Zinc Plated Yellow Chromate Finish

**NYLON THREAD
LOCKING ELEMENT IS
STANDARD ON ALL SIZES**
To order ball plungers
without a locking
element, simply add
an "X" to the end of
the part number (ex.
52821X). Pricing is the
same with or without
locking element.

Knurled Knob Hand Retractable Spring Plungers Steel & Stainless Steel: Locking

- Material:
 - Body: Steel or Stainless Steel
 - Plunger: Steel or Stainless Steel
- Unified ANSI and metric threads
- Hand retractable plunger can be easily engaged and withdrawn
- Chamfered plunger for easy alignment
- Built-in drive wrench for rapid installation and alignment
- Plunger can be completely withdrawn into the body and locked into a retracted position

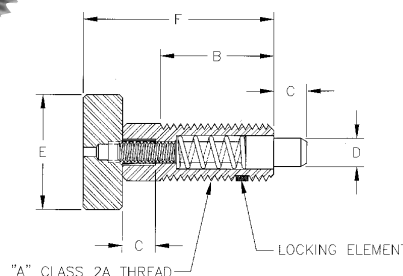

Steel Part No.*	Stainless Steel Part No.	End Force (lbs)		Thread A	B	C	+.001 -.001 D	E	F	Weight (lbs/100pcs)
		Initial	Final							
54610	54510	.50	2.0	1/4-20	.400	.125	.123	.50	.805	2
54611	54511	.50	3.0	3/8-16	.750	.22	.185	.75	1.26	6
54612	54512	.50	4.0	1/2-13	.650	.25	.248	1.0	1.38	8

*Zinc Plated Yellow Chromate Finish

Lever Type Plunger: Locking

- Plunger can be completely withdrawn into the body and locked into a retracted position
- Chamfered plunger for easy alignment
- Built in drive wrench for rapid installation and alignment

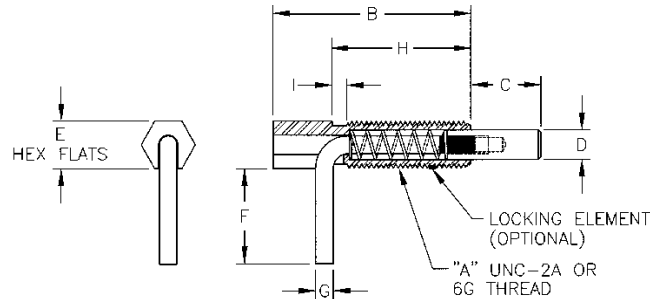

Steel* Part No.	Stainless Steel Part No.	End Force (lbs)		Thread A	B	C	D	Hex E	F	Dia G	H	I	Weight (lbs/100pcs)
		Initial	Final										
54305	54201	0.50	2.50	1/4-20	1.25	0.38	.16	.25	0.50	.09	0.80	*	2
54306	54202	0.75	3.75	3/8-16	2.00	0.56	.23	.38	0.75	.14	1.31	.13	5
54307	54203	1.00	5.00	1/2-13	2.11	0.75	.31	.50	0.93	.19	1.25	.15	10
54308	54204	1.00	5.00	5/8-11	3.05	1.00	.38	.62	1.00	.19	2.00	.18	15

*No thread relief in 1/4-20 thread size **Zinc Plated Clear Chromate Finish



METRIC

Steel** Part No.	Stainless Steel Part No.	End Force (lbs)		Thread A	B mm (in.)	C mm (in.)	D* mm (in.)	E mm (in.)	F mm (in.)	G mm (in.)	H mm (in.)	I mm (in.)
		Initial	Final									
64301	64201	.50	2.5	M6 x 1.0	32 (1.26)	10 (.39)	4 (.157)	6 (.236)	12.7 (.50)	2.3 (.09)	20 (.788)	*
64302	64202	.75	3.75	M10 x 1.5	51 (2)	14 (.55)	6 (.236)	10 (.39)	19 (.75)	3.5 (.14)	33 (1.3)	3.3 (1.3)
64303	64203	1.0	5.0	M12 x 1.75	54 (2.1)	19 (.75)	7 (.275)	12 (.47)	25.4 (1.0)	4.8 (.19)	32 (1.26)	3.8 (.15)

*No thread relief in M6 thread size **Zinc Plated Clear Chromate Finish

Steel Hand Retractable Spring Plunger: Locking

- Fully retractable plunger
- Chamfered plunger for easy alignment
- Easy withdrawing and re-engagement



Steel* Part No.	End Force (lbs)		A	B	Thread C	D	Hex E	Dia F	+0.000 -0.001 G	H
	Initial	Final								
54301	.50	2.50	1.25	.50	1/4-20	.38	1/4	.101	.155	.50
54302	.75	3.75	2.00	1.00	3/8-16	.56	3/8	.134	.234	.74
54303	1.0	5.0	2.11	1.11	1/2-13	.75	1/2	.188	.313	1.00

*Black Oxide Finish

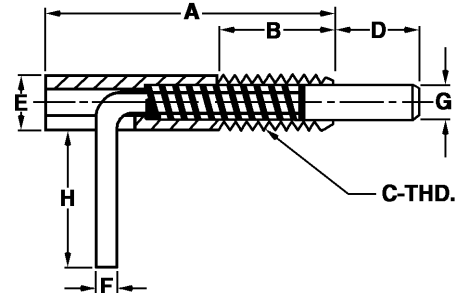

Lever Type Steel Plunger: Non-Locking

- Fully retractable plunger
- Chamfered plunger for easy alignment
- Easy withdrawing and re-engagement
- Zinc Plated Clear Chromate finish

Part No.	End Force (lbs)		Thread A	B	C	D	Hex E	F	G	H	I
	Initial	Final									
54310	.50	2.50	1/4-20	1.25	.38	.16	.25	.50	.09	.80	*
54311	.75	3.75	3/8-16	2.00	.56	.25	.38	.75	.14	1.31	.13
54312	1.0	5.0	1/2-13	2.00	.75	.31	.50	1.0	.19	1.25	.15
54313	1.0	5.0	5/8-11	3.05	1.0	.38	.62	1.0	.19	2.0	.18

*No thread relief in 1/4-20 thread size

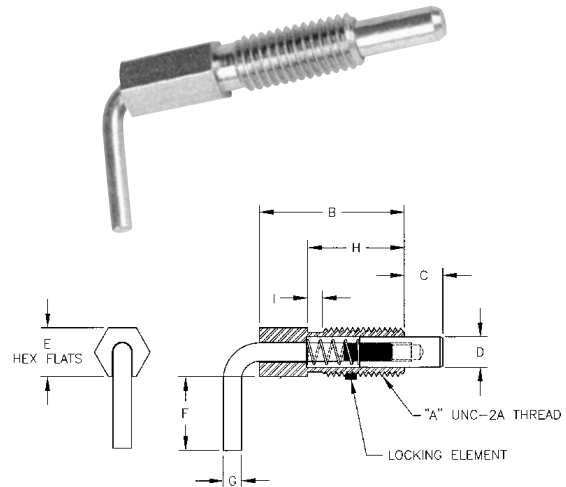

Lever Type Steel Stubby Plunger: Locking

- Designed for applications where space is limited
- Fully retractable plunger
- Chamfered plunger for easy alignment
- Zinc Plated Clear Chromate finish

Part No.	End Force (lbs)		Thread A	B	C	D	Hex E	F	G	H	I
	Initial	Final									
54350	.12	.50	1/4-20	.75	.20	.16	.25	.40	.09	.50	*
54351	.25	1.25	3/8-16	1.13	.30	.25	.38	.56	.14	.75	.13
54352	.50	2.0	1/2-13	1.50	.40	.31	.50	.75	.19	1.0	.15
54353	.75	2.5	5/8-11	1.88	.50	.38	.62	.88	.19	1.25	.18

*No thread relief in 1/4-20 thread size

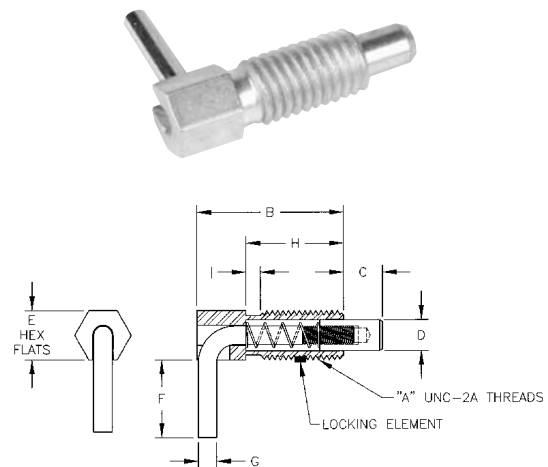

Lever Type Steel Stubby Plunger: Non-Locking

- Designed for applications where space is limited
- Fully retractable plunger
- Chamfered plunger for easy alignment
- Zinc Plated Clear Chromate finish

Part No.	End Force (lbs)		Thread A	B	C	D	Hex E	F	G	H	I
	Initial	Final									
54360	.12	.50	1/4-20	.75	.20	.16	.25	.40	.09	.50	*
54361	.25	1.25	3/8-16	1.13	.30	.25	.38	.56	.14	.75	.13
54362	.50	2.0	1/2-13	1.50	.40	.31	.50	.75	.19	1.0	.15
54363	.75	2.5	5/8-11	1.88	.50	.38	.62	.88	.19	1.25	.18

*No thread relief in 1/4-20 thread size

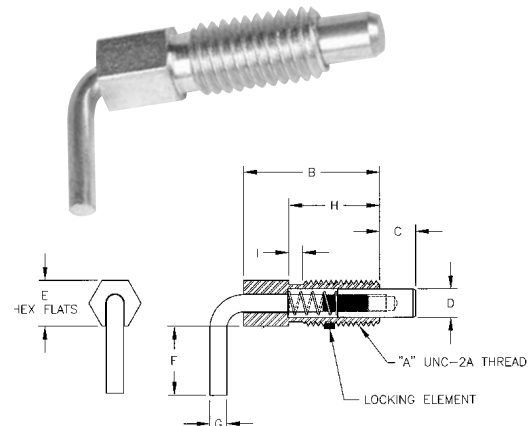

Hex Drive Knob Retractable: Locking

- Zinc gold chromate finish
- Hand-retractable locking plunger
- Withstands side loading
- Chamfered for easy alignment
- Built in hex drive wrench
- Plunger can be completely withdrawn into the body and locked into a retracted position



Part No.	End Force (lbs)		Thread A	B	C	D	E	F	Hex
	Initial	Final							
58501	1	4	1/4-20	.400	.125	.123	.750	.805	.125
58502	1	6	5/16-18	.530	.187	.154	.875	1.070	.125
58503	1	8	3/8-16	.750	.220	.185	1.000	1.260	.218
58504	1	10	1/2-13	.650	.250	.248	1.250	1.380	.250

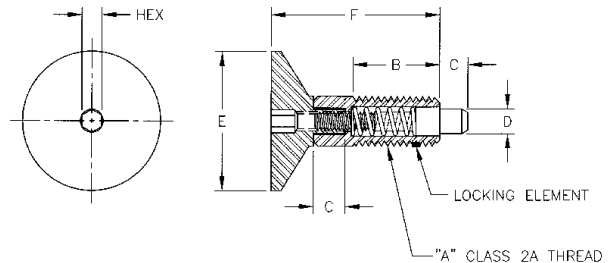

T-Handle Retractable Plunger: Locking

- Easy to grasp handle
- Locking plunger
- Withstands side loading
- Chamfered for easy alignment
- Plunger can be completely withdrawn into the body and locked into a retracted position

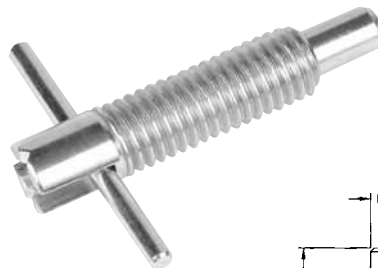

Steel Part No.*	Stainless Steel Part No.	End Force (lbs)		Thread A	B	C	D	E	F	G
		Initial	Final							
57701	57750	1.0	2.5	1/4-20	1.14	.250	.155	1.13	.13	.8
57702	57751	2.0	4.0	3/8-16	1.68	.375	.233	1.50	.13	1.2
57703	57752	2.0	5.0	1/2-13	2.00	.500	.312	2.00	.16	1.4
57704	57753	2.5	5.0	5/8-11	2.38	.625	.375	2.50	.19	1.7

*Zinc Plated Clear Chromate Finish

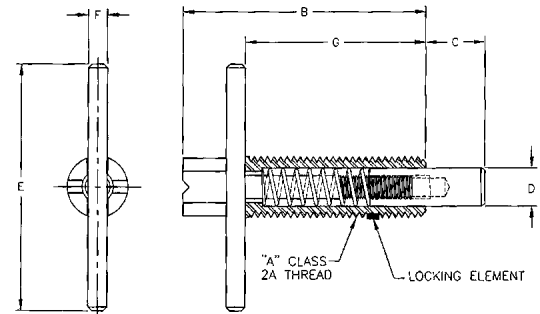

NYLON THREAD LOCKING ELEMENT IS STANDARD ON ALL SIZES SHOWN ON THIS PAGE
To order ball plungers without a locking element, simply add an "X" to the end of the part number (ex. 52821X). Pricing is the same with or without locking element.

SPRING LOADED DEVICES



Spring Stops

- Material:
 - Body: Aluminum
 - Nose: Steel
- Part Nos. 53100 and 53103 have triangular bodies
- Part Nos. 53101, 53102, 53104 and 53105 have squared bodies as denoted by phantom line drawing
- Two nose styles available:
 - 53100-53102: Square Nose
 - 53103-53105: Round Button Nose
- Ideal for holding and securing parts while clamping

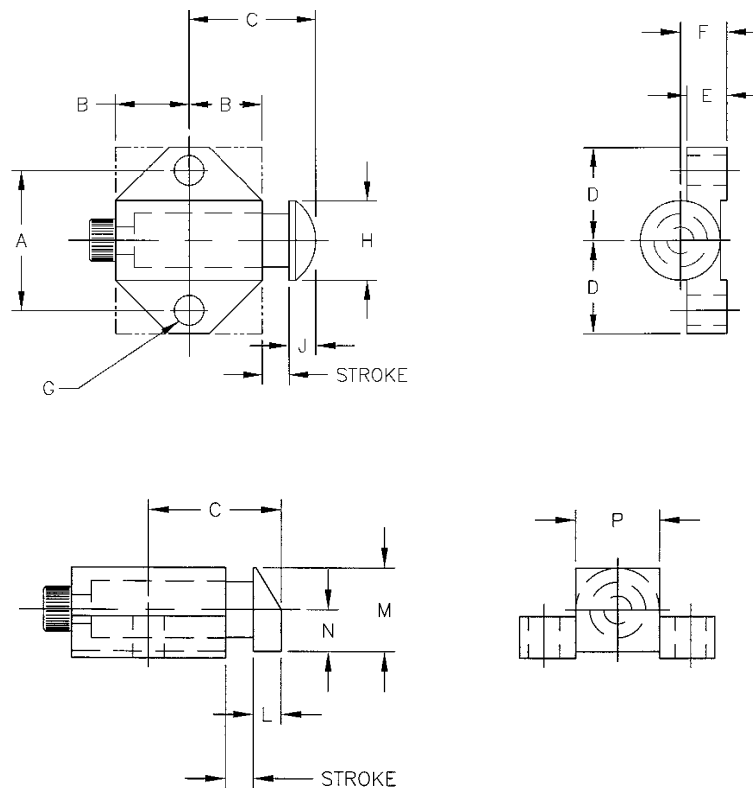

Part No.	End Force (lbs)		Stroke	A	B	C	D	E	F	G	H	J	L	M	N	P	Nose Style
	Initial	Final															
53100	5	15	1/8	21/32	11/32	19/32	7/16	3/16	7/32	0.128	-	-	1/8	3/8	3/16	3/8	Square
53101	2	26	3/16	1-1/8	1/2	15/16	3/4	1/4	5/16	0.193	-	-	1/4	5/8	5/16	5/8	Square
53102	16	48	1/4	1-1/2	11/16	1-1/4	1	5/16	17/32	0.257	-	-	5/16	3/4	3/8	3/4	Square
53103	5	15	1/8	21/32	11/32	19/32	7/16	3/16	7/32	0.128	3/8	1/8	-	-	-	-	Round Button
53104	2	26	3/16	1-1/8	1/2	7/8	3/4	1/4	5/16	0.193	9/16	3/16	-	-	-	-	Round Button
53105	16	48	1/4	1-1/2	11/16	1-11/64	1	1/8	17/32	0.257	13/16	1/4	-	-	-	-	Round Button



SPRING LOADED DEVICES

Special Hand Retractable Plunger Quotation Form

Name _____
 Company _____
 Phone _____ Fax _____
 Email _____

**Please photocopy
 this page as needed
 for quotation
 purposes**

PULL RING

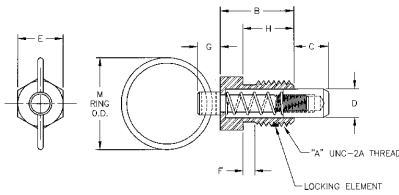

Stubby Non-Locking Type

Thread "A" _____
 Body Length "B" _____
 Nose Length "C" _____
 Nose Diameter "D" _____
 Hex Flats "E" _____
 Relief Length "F" _____
 Pin Protrusion "G" _____
 Shank Length "H" _____
 Ring Diameter "M" _____

DELRIN KNOB

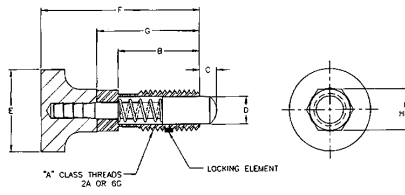

Non-Locking Type

Thread "A" _____
 Shank Length "B" _____
 Nose Length "C" _____
 Nose Diameter "D" _____
 Knob Diameter "E" _____
 Handle-to-Body "F" _____
 Body Length "G" _____
 Hex Flats "H" _____

KNURLED KNOB

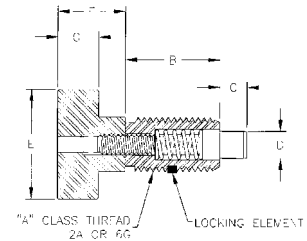

Non-Locking Type

Thread "A" _____
 Body Length "B" _____
 Nose Length "C" _____
 Nose Diameter "D" _____
 Knob Diameter "E" _____
 Knob Length "F" _____
 Knob Thickness "G" _____

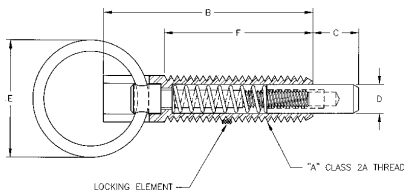

Standard Locking Type

Thread "A" _____
 Body Length "B" _____
 Nose Length "C" _____
 Nose Diameter "D" _____
 Ring Diameter "E" _____
 Thread Length "F" _____

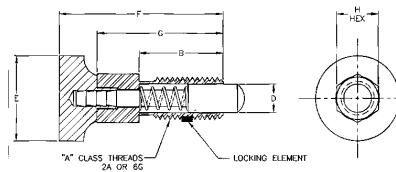

Locking Type

Thread "A" _____
 Shank Length "B" _____
 Nose Length "C" _____
 Nose Diameter "D" _____
 Knob Diameter "E" _____
 Handle-to-Body "F" _____
 Shank Length "G" _____
 Hex Flats "H" _____

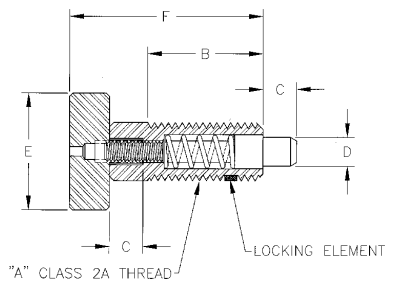

Locking Type

Thread "A" _____
 Thread Length "B" _____
 Nose Length "C" _____
 Nose Diameter "D" _____
 Knob Diameter "E" _____
 Handle-to-Body "F" _____

SPRING LOADED DEVICES



L-HANDLE

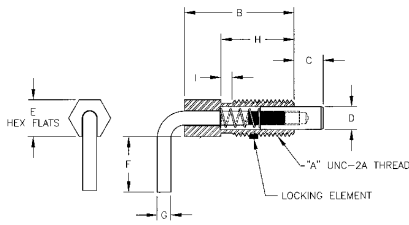

Standard Non-Locking Type

Thread "A" _____
 Body Length "B" _____
 Nose Length "C" _____
 Nose Diameter "D" _____
 Hex Length "E" _____
 Handle Length "F" _____
 Handle Diameter "G" _____
 Shank Length "H" _____
 Relief Length "I" _____

STUBBY L-HANDLE

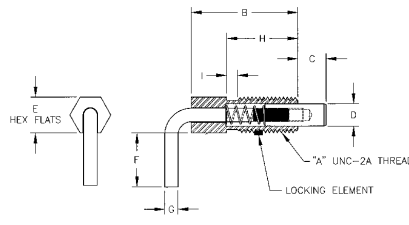

Stubby Non-Locking Type

Thread "A" _____
 Body Length "B" _____
 Nose Length "C" _____
 Nose Diameter "D" _____
 Hex Length "E" _____
 Handle Length "F" _____
 Handle Diameter "G" _____
 Shank Length "H" _____
 Relief Length "I" _____

HEX DRIVE KNOB

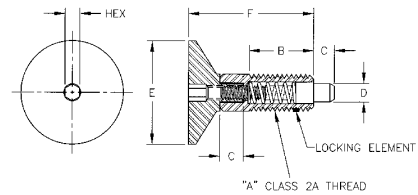

Locking Type

Thread "A" _____
 Thread Length "B" _____
 Nose Length "C" _____
 Nose Diameter "D" _____
 Knob Diameter "E" _____
 Handle-to-Body "F" _____
 Hex "G" _____

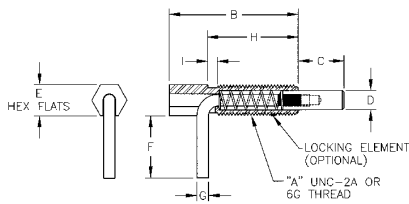

Standard Locking Type

Thread "A" _____
 Body Length "B" _____
 Nose Length "C" _____
 Nose Diameter "D" _____
 Hex Length "E" _____
 Handle Length "F" _____
 Handle Diameter "G" _____
 Shank Length "H" _____
 Relief Length "I" _____

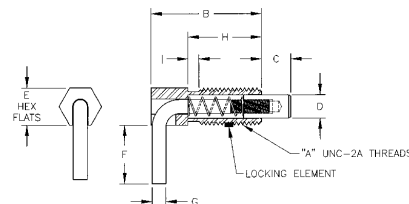

Stubby Locking Type

Thread "A" _____
 Body Length "B" _____
 Nose Length "C" _____
 Nose Diameter "D" _____
 Hex Length "E" _____
 Handle Length "F" _____
 Handle Diameter "G" _____
 Shank Length "H" _____
 Relief Length "I" _____

T-HANDLE

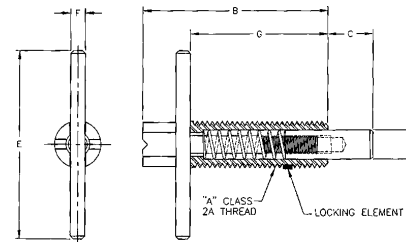

Locking Type

Thread "A" _____
 Body Length "B" _____
 Nose Length "C" _____
 Nose Diameter "D" _____
 Handle Length "E" _____
 Handle Diameter "F" _____
 Thread Length "G" _____

OTHER REQUIRED INFORMATION

Locking Element: Yes No

End Force: Initial _____ Final _____ Body Material & Finish: _____

Nose Material & Finish: _____ Spring Material: _____ Quantity: _____

Required Delivery: _____ Environmental Conditions: _____



SPRING LOADED DEVICES

Installation Information for TE-CO Spring Loaded Devices

Most TE-CO Spring & Ball Plungers can be installed using a screwdriver, hex key wrench, or spring/ball plunger wrench (see page 100). Also, many Hand Retractable Spring Plungers can be installed without using any tools by simply using its knob to engage the threads. Because spring loaded devices have hollow bodies, the maximum installation torques they can withstand are significantly less than bolts or screws. The table below should be used as a guideline for installing spring loaded devices.

Unified Thread Size	Metric Thread Size	Max Installation Torque (inch pounds)
No. 4	M2.5 x 0.45	.60
No. 5	M3 x 0.5	1.25
No. 6	M3.5 x 0.6-6g	1.65
No. 8	M4 x 0.7-6g	2.15
No. 10	M5 x 0.8-6g	3.15
1/4	M6 x 1-6g	6.0
5/16	M8 x 1.25	11.0
3/8	M10 x 1.5	16.0
7/16	M11 x 1.5	22.0
1/2	M12 x 1.75	28.0
9/16	M14 x 2.0	36.0
5/8	M16 x 2.0	55.0
3/4	M20 x 2.5	70.0
7/8	M22 x 2.5	95.0
1	M24 x 3.0	130.0
1-1/8	M30 x 3.5	160.0
1-1/4	M33 x 3.5	190.0

Most TE-CO Spring Loaded Devices can be ordered with or without a nylon thread locking element (see each product group for details). The nylon-locking element forces the threads on the opposite side of a spring loaded device to compress against the mating threads of a tapped hole, providing the thread locking property. The nylon-locking element can cause installation problems when installing into softer metals or aluminum. This can be prevented by either using a larger tap drill when tapping, by ordering a spring plunger without a locking element, or by requesting a quote for a special plunger that will fit your needs.

When installing spring loaded devices with a nylon thread locking element pellet (thread sizes 5/16" and larger or M8 and larger), TE-CO recommends that the tapped installation hole be countersunk 90 degrees by 1/32 larger than major thread diameter to prevent damage to the locking element.

For more detailed information you may contact any of our knowledgeable TE-CO Customer Service Representatives at 800-543-4071.

Inch Tap Drill Sizes Table for Spring Plungers

Tap	Tap Drill	Decimal Equiv. of Tap Drill	Probable Hole Size	Percent Of Thread %
4-48	42	0.0935	0.0955	61
	3/32	0.0938	0.0958	60
	41	0.0960	0.0980	52
5-40	40	0.098	0.1003	76
	39	0.0995	0.1018	71
	38	0.1015	0.1038	65
	37	0.1040	0.1063	58
	37	0.1040	0.1063	78
6-32	36	0.1065	0.1091	71
	7/64	0.1094	0.1120	64
	35	0.1100	0.1126	63
	34	0.1110	0.1136	60
	33	0.1130	0.1156	55
6-40	34	0.1110	0.1136	75
	33	0.1130	0.1156	69
	32	0.1160	0.1186	60
8-32	29	0.1360	0.1389	62
	28	0.1405	0.1434	51
8-36	29	0.1360	0.1389	70
	28	0.1405	0.1434	57
	9/64	0.1406	0.1435	57
10-32	5/32	0.1563	0.1595	75
	22	0.1570	0.1602	73
	21	0.1590	0.1622	68
	20	0.1610	0.1642	64
	19	0.1660	0.1692	51
1/4-20	9	0.1960	0.1998	77
	8	0.1990	0.2028	73
	7	0.2010	0.2048	70
	13/64	0.2031	0.2069	66
	6	0.2040	0.2078	65
	5	0.2055	0.2093	63
	4	0.2090	0.2128	57
1/4-28	3	0.2130	0.2168	72
	7/32	0.2188	0.2226	59
	2	0.2210	0.2248	55
5/16-18	F	0.257	0.2608	72
	G	0.261	0.2651	66
	17/64	0.2656	0.2697	59
	H	0.2660	0.2701	59
3/8-16	5/16	0.3125	0.3169	72
	O	0.3160	0.3204	68
	P	0.3230	0.3274	59
1/2-13	27/64	0.4219	0.4266	73
	7/16	0.4375	0.4422	58
5/8-11	17/32	0.5313	0.5362	75
	36/64	0.5469	0.5518	62
3/4-10	41/64	0.6406	0.6456	80
	21/32	0.6563	0.6613	68
1-8	55/64	0.8594	0.8653	83
	7/8	0.8750	0.8809	73
	57/64	0.8906	0.8965	64
	29/32	0.9063	0.9122	54

Visit our NEW & IMPROVED Website!

Home Page



Spring & Ball Plunger Product Group Page

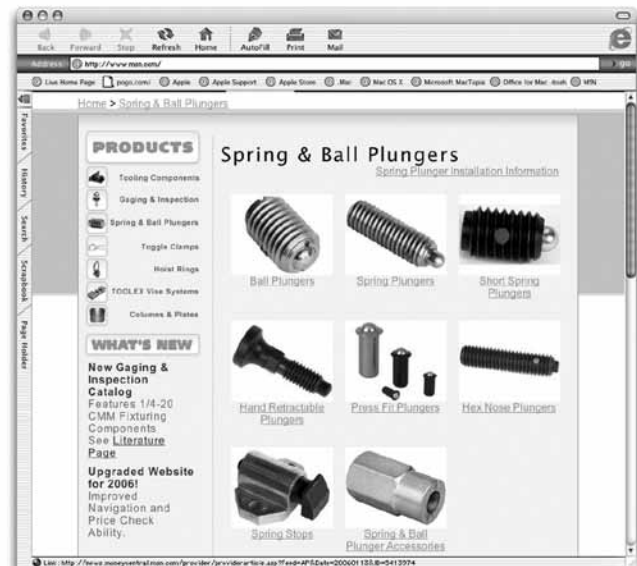

Features include:

- Easy pictorial navigation
- Competitor conversion function
- 2D & 3D CAD files for download
- List price under product number
- TE-CO representative locator
- View available literature

www.te-co.com