

COLUMNS & PLATES

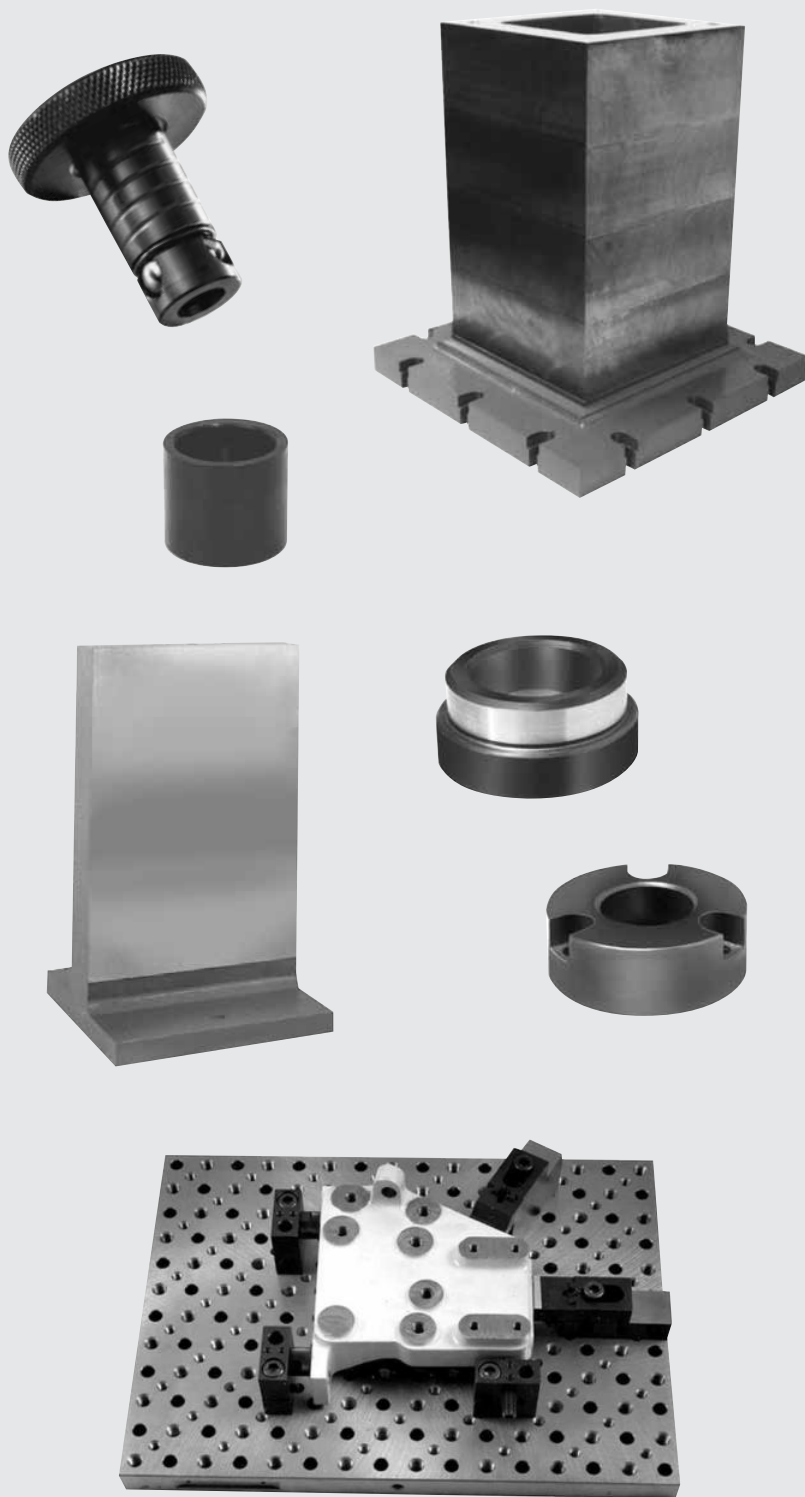

Fixture Plates.....206

Ball Lock Shanks & Liners207

Ball Lock Receiver Bushings207

Columns.....208

T-Columns209

Mounting Information.....210

Quotation Worksheets

Tooling Plates.....211

Columns..... 212-213

T-Columns..... 214-215

Fixture Plates

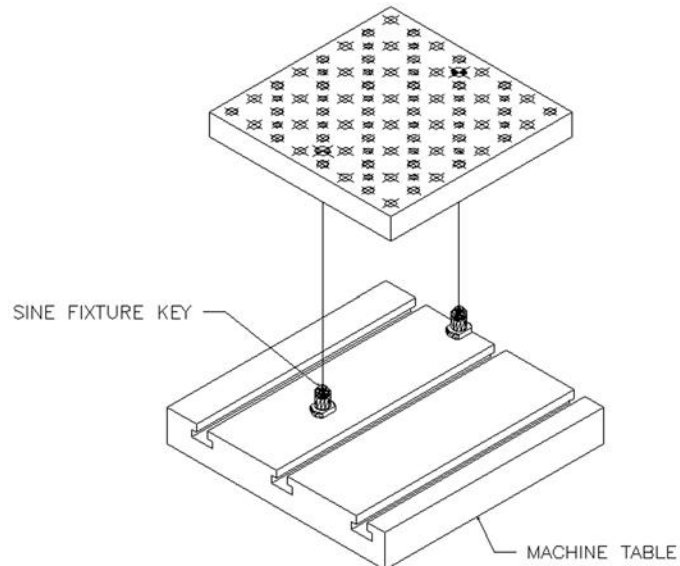
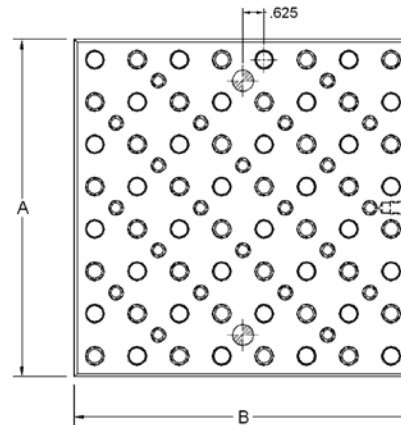
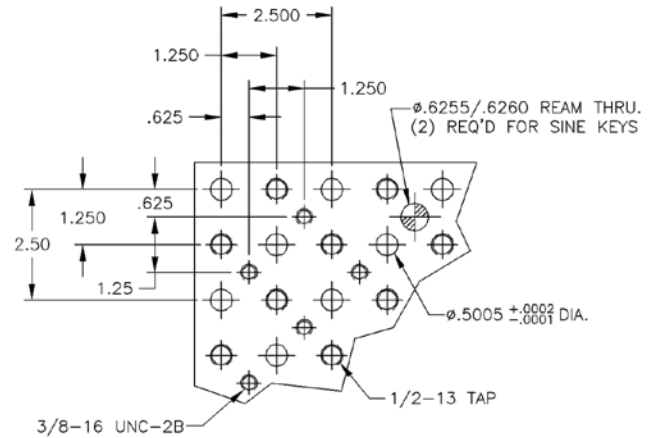
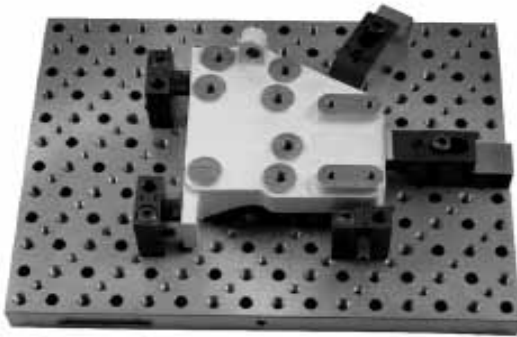

- Extensive tapped dowel pin hole configuration provides the flexibility to accurately and quickly fixture practically any workpiece or mount any vise.
- Fixture plates consist of alternating 1/2" dowel pin holes for workpiece location, along with 1/2" and 3/8" tapped holes for clamping.
- Can be accurately located on machine tables by utilizing two reamed 5/8" centerline sine key holes.
- Non-standard sizes and mounting configurations are available and will be quoted upon request – otherwise, mounting holes must be added by the customer.
- TE-CO supports these products with a full line of tooling components for your fixturing needs (pages 2-70).
- Hoist rings are also available for proper material handling (pages 139-159).

Material Tolerances:

- C1119 Steel or equivalent
- Blanchard ground flat and parallel to .002 in 12"
- Tapped holes on location $\pm.005$
- Dowel holes on location $\pm.001$
- All plates are 1.2" thick

Part No.	A	B	Approx. Weight
25020	10	10	34 lbs.
25021	15	10	51 lbs.
25022	20	15	102 lbs.
25023	20	20	136 lbs.

Ball Lock™ Shanks and Liners

- Shank & Bushing Material 4340
- Liner Material 52100
- Black Oxide Finish
- Heat treatment:
 - Shanks: Rc 40-45
 - Bushings: Rc 50-54
 - Liners: Rc 62-64

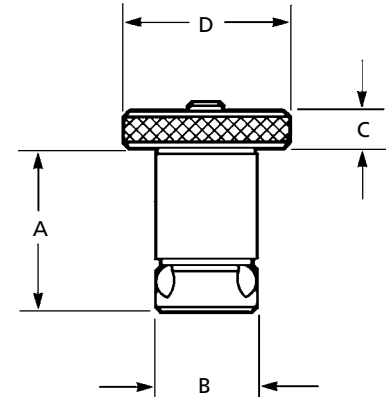
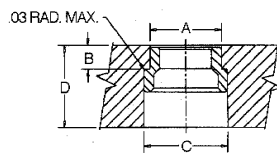

Plate Thickness ± .005 A	Shank Part No.	Shank Dia. (MM) B	C	D	E	Max. Holddown Force (lbs)	Max. Screw Torque (lbs/ft)	Primary Liner Part No.	Secondary Liner Part No.	Liner O.D. +.0000 -.0004
0.50	49605	13	0.25	0.87	1.08	750	1.2	49705	49805	0.7518
0.75	49606	13	0.25	0.87	1.33	750	1.2	49706	49806	0.7518
0.50	49607	16	0.32	1.50	1.15	1,200	3	49707	49807	1.0018
0.75	49608	16	0.32	1.50	1.40	1,200	3	49708	49808	1.0018
0.75	49601	20	0.38	1.75	1.53	3,000	4	49701	49801	1.3772
1.00	49602	20	0.38	1.75	1.78	3,000	4	49702	49802	1.3772
0.75	49611	25	0.38	2.00	1.70	7,000	9	49711	49811	1.3772
1.00	49612	25	0.38	2.00	1.95	7,000	9	49712	49812	1.3772
0.75	49621	30	0.50	2.25	1.88	10,000	15	49721	49821	1.7523
1.00	49622	30	0.50	2.25	2.13	10,000	15	49722	49822	1.7523
0.75	49631	35	0.50	2.25	1.97	15,500	25	49731	49831	1.7523
1.00	49632	35	0.50	2.25	2.22	15,500	25	49732	49832	1.7523
1.50	49633	35	0.50	2.25	2.72	15,500	25	49733	49833	1.7523
2.00	49634	35	0.50	2.25	3.22	15,500	25	49734	49834	1.7523
0.75	49641	50	0.75	3.00	2.45	20,000	50	49741	49841	2.5025
1.00	49642	50	0.75	3.00	2.70	20,000	50	49742	49842	2.5025
1.50	49643	50	0.75	3.00	3.20	20,000	50	49743	49843	2.5025
2.00	49644	50	0.75	3.00	3.70	20,000	50	49744	49844	2.5025

Ball Lock™ Receiver Bushings



Back Mount



Back Mount



Face Mount

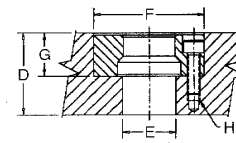

Face Mount

Back Mount						Face Mount							
Shank Dia. (MM)	Back Mount Part No.	Actual O.D. +.0000 -.0004 A	Depth +.000 -.002 B	C'bore ±.006 C	Min. Subplate Thickness D	Face Mount Part No.	Actual O.D. +.0000 -.0004	Min. Subplate Thickness D	Clearance Drill Dia. E	Bore +.0005 -.0000 F	Depth +.002 -.000 G	Tap Size Depth H	Bolt Circle Dia.
13	49516	0.7870	0.277	1.000	3/4	49506	1.3750	3/4	11/16	1.3750	0.469	8-32x5/16	0.984
16	49517	0.8760	0.285	1.155	3/4	49507	1.4370	3/4	13/16	1.4370	0.469	8-32x5/16	1.125
20	49511	1.0950	0.345	1.280	7/8	49501	1.6873	1-1/8	13/16	1.6873	0.637	10-32x3/8	1.362
25	49512	1.3763	0.416	1.593	1	49502	2.0623	1-1/4	1	2.0623	0.799	1/4-28x1/2	1.644
30	49513	1.6264	0.432	1.906	1-1/4	49503	2.2654	1-1/4	1-3/16	2.2654	0.871	1/4-28x3/4	1.876
35	49514	1.8764	0.493	2.155	1-5/16	49504	2.6873	1-3/8	1-9/16	2.6873	0.904	5/16-24x7/8	2.178
50	49515	2.6269	0.621	2.988	1-3/4	49505	3.4998	1-13/16	2-5/32	3.4998	1.239	3/8-24x1	2.916

*Ball Lock is a trademark of Jergens, Inc.

COLUMNS & PLATES



Columns

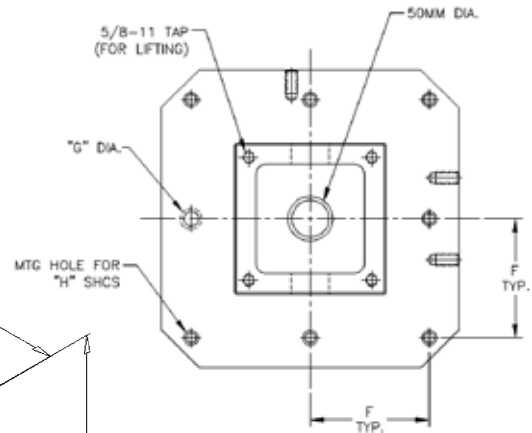
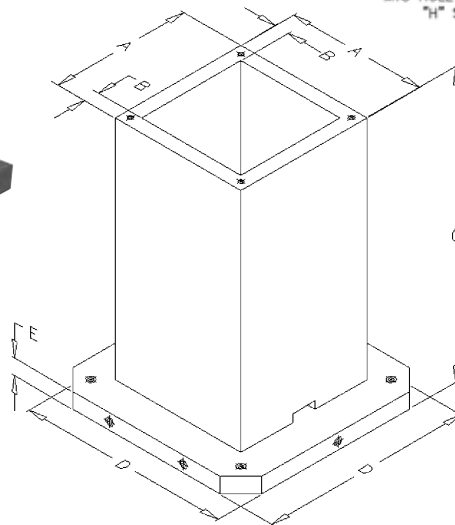

English

Part No.	A	B	C	D	E	F	G	H	Approx. Weight
25311	6.00	1.12	18.00	12.60	1.50	4.96	20mm	1/2" or M12	170 lbs.
25300	8.00	1.12	21.50	15.70	1.75	6.30	20mm	1/2" or M12	330 lbs.
25301	10.00	1.12	25.50	15.70	1.75	6.30	20mm	1/2" or M12	430 lbs.
25302	8.00	1.12	21.75	19.70	2.00	7.87	20mm	1/2" or M12	430 lbs.
25303	10.00	1.12	25.75	19.70	2.00	7.87	20mm	1/2" or M12	530 lbs.
25304	12.00	1.25	31.75	19.70	2.00	7.87	20mm	1/2" or M12	725 lbs.
25305	14.00	1.25	31.75	19.70	2.00	7.87	20mm	1/2" or M12	810 lbs.
25306	8.00	1.12	22.00	24.80	2.25	9.84	25mm	5/8" or M16	610 lbs.
25307	10.00	1.12	26.00	24.80	2.25	9.84	25mm	5/8" or M16	710 lbs.
25308	12.00	1.25	32.00	24.80	2.25	9.84	25mm	5/8" or M16	900 lbs.
25309	14.00	1.25	32.00	24.80	2.25	9.84	25mm	5/8" or M16	1000 lbs.
25310	16.00	1.50	32.00	24.80	2.25	9.84	25mm	5/8" or M16	1175 lbs.

Metric

Part No.	A	B	C	D	E	F	G	H	Approx. Weight
65300	200	27	550	400	45	160	20mm	M12 or 1/2"	330 lbs.
65301	250	27	650	400	45	160	20mm	M12 or 1/2"	430 lbs.
65302	200	27	555	500	50	200	20mm	M12 or 1/2"	430 lbs.
65303	250	27	655	500	50	200	20mm	M12 or 1/2"	530 lbs.
65304	300	30	805	500	50	200	20mm	M12 or 1/2"	725 lbs.
65305	350	30	805	500	50	200	20mm	M12 or 1/2"	810 lbs.
65306	200	27	560	630	55	250	25mm	M16 or 5/8"	610 lbs.
65307	250	27	660	630	55	250	25mm	M16 or 5/8"	710 lbs.
65308	300	30	810	630	55	250	25mm	M16 or 5/8"	900 lbs.
65309	350	30	810	630	55	250	25mm	M16 or 5/8"	1000 lbs.
65310	400	35	810	630	55	250	25mm	M16 or 5/8"	1175 lbs.

- Provides an accurate fixturing base for workpieces on horizontal and multi-axis machining centers.
- Provide a locating and mounting base for fixture plates.
- Material: One-piece stress relieved class 40 Meehanite cast iron or equivalent.
- Base and sides are milled flat, parallel, and square to .001 in 12".
- Columns are provided with the standard DIN and JIS mounting configuration (see page 206) and coolant drain holes.
- Columns are plain, without a grid pattern or holes, on all four sides.
- Grid patterns, non-standard mounting configurations, and special sizes are available and will be quoted upon request. See pages 212 and 213 for column quotation worksheets.
- TE-CO supports these products with a full line of tooling components for your fixturing needs (pages 2-70).
- Hoist rings are also available for proper material handling (pages 139-159).

T-Columns

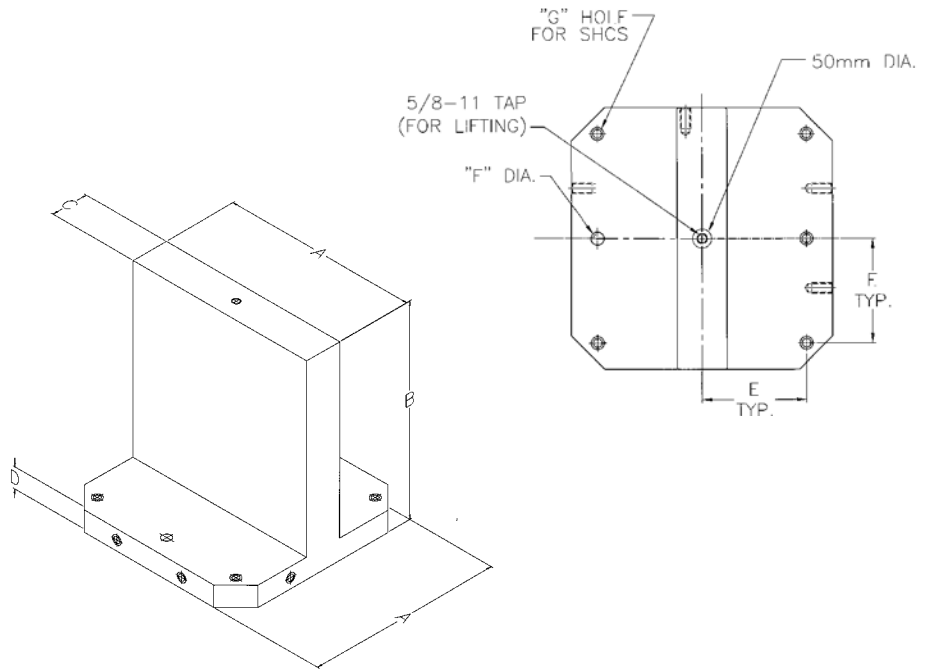

English

Part No.	A	B	C	D	E	F	G	Approx. Weight
25400	15.70	18.00	3.00	1.75	6.30	20mm	1/2" or M12	370 lbs.
25401	15.70	24.00	4.00	1.75	6.30	20mm	1/2" or M12	550 lbs.
25402	19.70	18.00	2.00	2.00	7.87	20mm	1/2" or M12	438 lbs.
25403	19.70	24.00	4.00	2.00	7.87	20mm	1/2" or M12	750 lbs.
25404	19.70	30.00	6.00	2.00	7.87	20mm	1/2" or M12	1175 lbs.
25405	24.80	24.00	4.00	2.25	9.84	25mm	5/8" or M16	1065 lbs.
25406	24.80	30.00	6.00	2.25	9.84	25mm	5/8" or M16	1595 lbs.
25407	12.60	15.50	3.00	1.50	4.96	20mm	3/8" or M10	225 lbs.

Metric

Part No.	A	B	C	D	E	F	G	Approx. Weight
65400	400	455	80	45	160	20mm	M12 or 1/2"	370 lbs.
65401	400	610	100	45	160	20mm	M12 or 1/2"	550 lbs.
65402	500	455	50	50	200	20mm	M12 or 1/2"	438 lbs.
65403	500	610	100	50	200	20mm	M12 or 1/2"	750 lbs.
65404	500	760	150	50	200	20mm	M12 or 1/2"	1175 lbs.
65405	630	610	100	55	250	25mm	M16 or 5/8"	1065 lbs.
65406	630	760	150	55	250	25mm	M16 or 5/8"	1595 lbs.

- Provides an accurate fixturing base for workpieces on horizontal and multi-axis machining centers.
- Provide a locating and mounting base for fixture plates.
- Material: One-piece stress relieved class 40 Meehanite cast iron or equivalent.
- Base and upright thickness are milled flat, parallel, and square to .001 in 12".
- T-Columns are provided with the standard DIN and JIS mounting configuration (see page 209).
- T-Columns are plain, without a grid pattern or holes, on all four sides.
- Grid patterns, non-standard mounting configurations, and special sizes are available and will be quoted upon request. See pages 214 and 215 for T-column quotation worksheets.
- TE-CO supports these products with a full line of tooling components for your fixturing needs (pages 2-70).
- Hoist rings are also available for proper material handling (see pages 139-159).

Mounting Types for Tooling Blocks

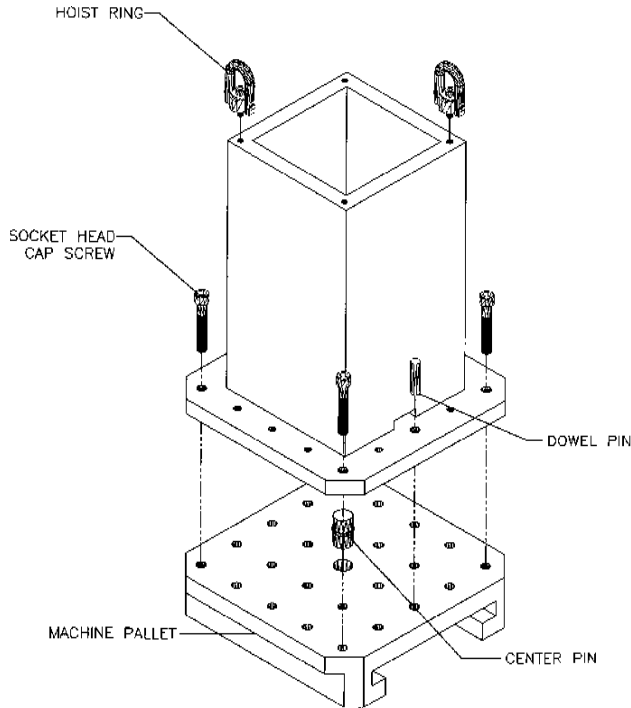

DIN Mounting

DIN Mounting incorporates a precision center hole for centering the Tooling Block and a precision offset radial hole for radial location on the pallet. To fasten the Tooling Block or plate once it has been located, simply tighten the Socket Head Cap Screws to the pallet.

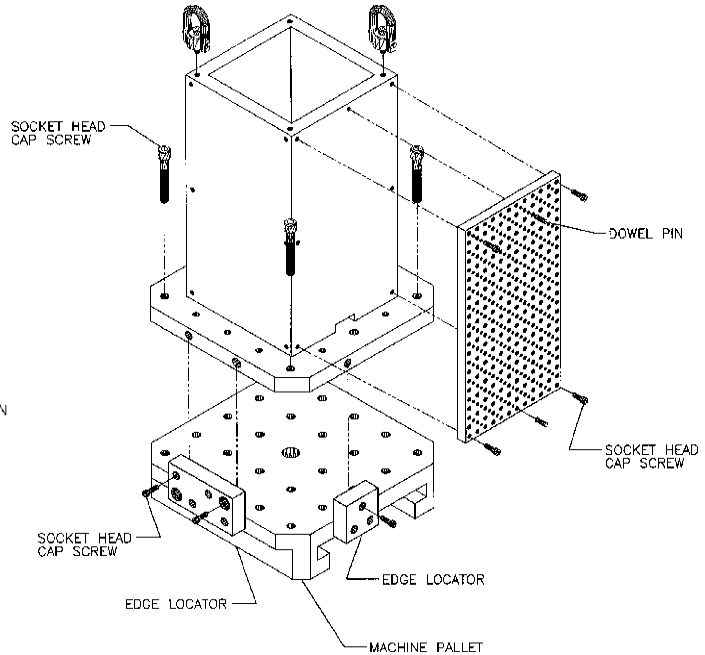

JIS Mounting

The Tooling Block or Plate is located onto a pallet by using two edges that have been precision ground that are perpendicular or 90 degree to each other. The Tooling Block or Plate is then located so that these surfaces are tight against the locators on the pallet. Socket Head Cap Screws are then used to securely fasten the Tooling Block tight against the locators, and onto the Machine Pallet. For hole location specs, see below.

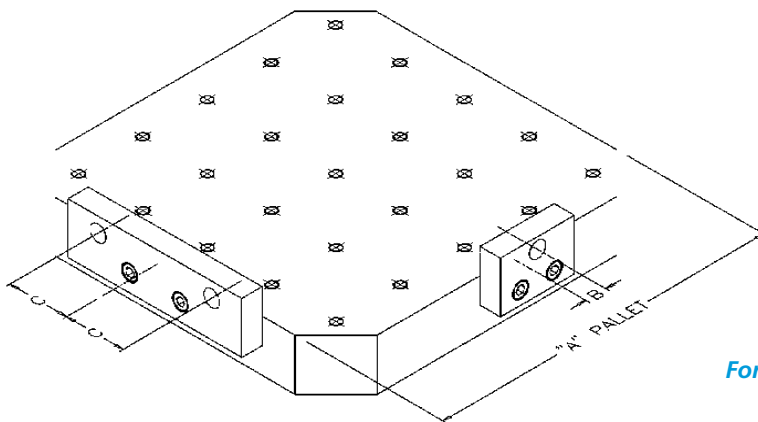

Pallet Size	A	B	C
400	.984	2.165	
500	.984	2.953	
600	.984	3.937	

For 12.60 pallet size, call factory for JIS mounting configuration

Tooling Plate Quotation Worksheet

Special Request For Quotation:

If you have a requirement that can not be met with one of our standards, please do the following:

1. Photocopy this page and the previous page – if it applies – for an accurate quote.
2. Fill in the information concerning the product that will be quoted. Sketch in any information that is not provided, being as detailed as possible.
3. Mail or fax the RFQ sheet to TE-CO.
4. **Note: If ordered, this item will be manufactured directly from the information provided on this page. Please be sure information is correct. Authorized signature is required.**
5. Please draw in mounting holes or specification required for mounting to a pallet or machine table.
6. Please draw in any dimension holes needed in the face for fixtures. Be sure to include all information requested in the chart below.

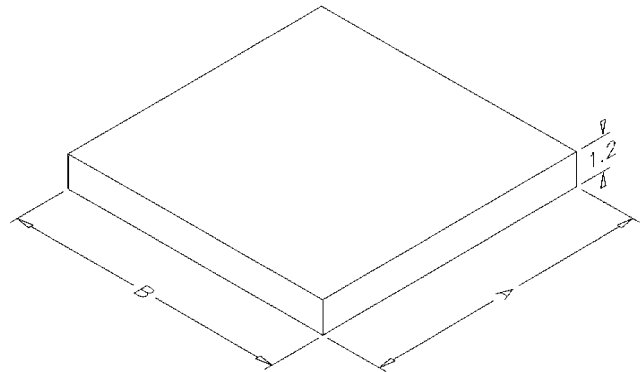

Hole Specifications					
	Hole Type	Hole Size	Hole Tolerance	Location Tolerance	Quantity of Holes
Ex:	Dowel	1/2"	±.0005	±.001	20
	1)				
	2)				
	3)				

Cut corners on base: (Specify size and angle)

Yes _____

No _____

Authorized Signature: _____ Date: _____

****Specials may require extended delivery time.**

Column Quotation Worksheet

Special Request For Quotation:

If you have a requirement that can not be met with one of our standards, please do the following:

1. Photocopy this page and the previous page – if applicable – for an accurate quote.
2. Fill in the information concerning the product that will be quoted. Sketch in any information that is not provided, being as detailed as possible.
3. Mail or fax the RFQ sheet to TE-CO.
4. **Note: If ordered, this item will be manufactured directly from the information provided on this page. Please be sure information is correct. Authorized signature is required.**

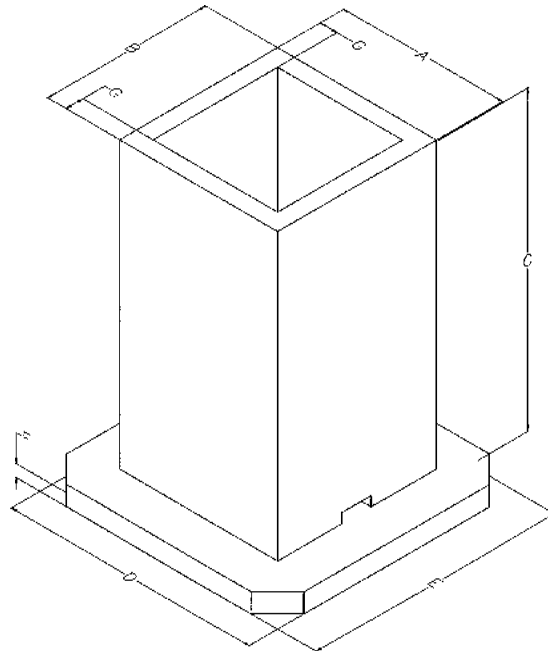

Quoting Information:

Fill in following table by matching the dimensions with the respective letter.

	A	B	C	D	E	F	G
Ex:	10.00	8.00	2.00	15.70	13.70	8.00	6.00
1)							
2)							
3)							

Company Name: _____

Address: _____

City: _____ State: ____ Zip: _____

Phone: _____

Authorized Signature: _____

****Specials may require extended delivery time.**

Special Remarks: _____

Tolerances:

Flatness: _____ .001/12.0" Std.

Parallelism: _____ .001/12.0" Std.

Perpendicularity: _____ .001/12.0" Std.

Material: (Check one and specify type)

Casting: _____

Weldment: _____

Column Quotation Worksheet

Special Request For Quotation:

If you have a requirement that can not be met with one of our standards, please do the following:

1. Photocopy this page and the previous page – if applicable – for an accurate quote.
2. Fill in the information concerning the product that will be quoted. Sketch in any information that is not provided, being as detailed as possible.
3. Mail or fax the RFQ sheet to TE-CO.
4. **Note: If ordered, this item will be manufactured directly from the information provided on this page. Please be sure information is correct. Authorized signature is required.**
5. Please draw in mounting holes or specification required for mounting to a pallet or machine table.
6. Please draw in any dimension holes needed in the face for fixtures. Be sure to include all information requested in the chart below.

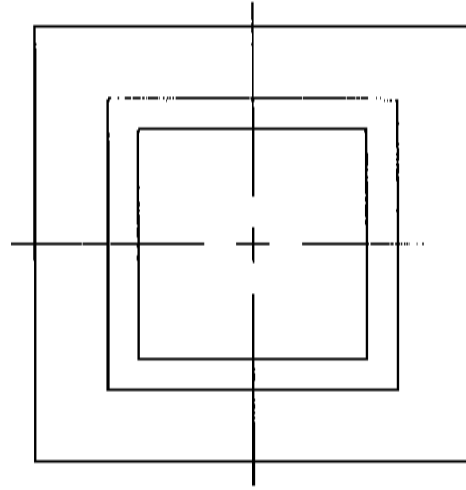

Hole Specifications					
	Hole Type	Hole Size	Hole Tolerance	Location Tolerance	Quantity of Holes
Ex:	Dowel	1/2"	±.0005	±.001	20
	1)				
	2)				
	3)				

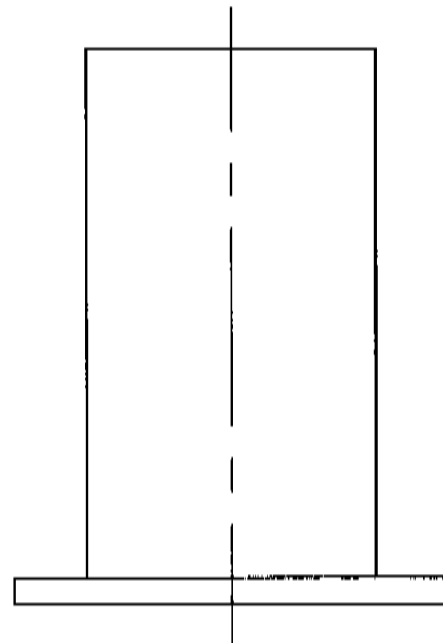

Cut Corners on Base: (Specify size and angle)

Yes _____

No _____

Authorized Signature: _____ Date: _____

****Specials may require extended delivery time.**

T-Column Quotation Worksheet

Special Request For Quotation:

If you have a requirement that can not be met with one of our standards, please do the following:

1. Photocopy this page and the previous page – if applicable – for an accurate quote.
2. Fill in the information concerning the product that will be quoted. Sketch in any information that is not provided, being as detailed as possible.
3. Mail or fax the RFQ sheet to TE-CO.
4. **Note: If ordered, this item will be manufactured directly from the information provided on this page. Please be sure information is correct. Authorized signature is required.**

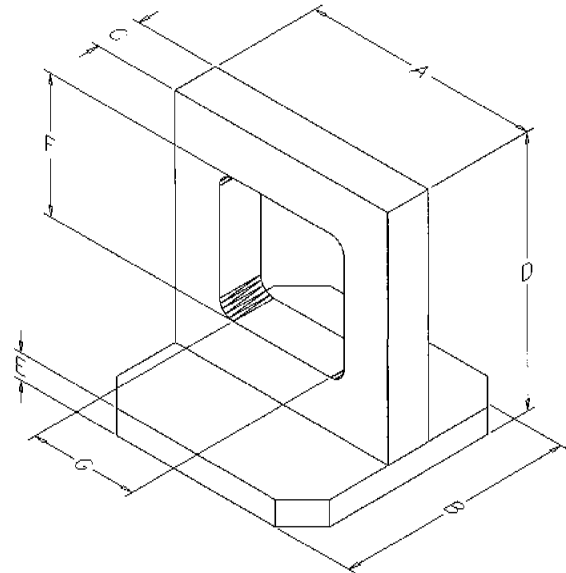

Quoting Information:

Fill in following table by matching the dimensions with the respective letter.

	A	B	C	D	E	F	G
Ex:	10.00	8.00	2.00	15.70	13.70	8.00	6.00
1)							
2)							
3)							

Special Remarks: _____

Company Name: _____

Address: _____

City: _____ State: ____ Zip: _____

Phone: _____

Authorized Signature: _____

****Specials may require extended delivery time.**

Tolerances:

Flatness: _____ .001/12.0" Std.

Parallelism: _____ .001/12.0" Std.

Perpendicularity: _____ .001/12.0" Std.

Material: (Check one and specify type)

Casting: _____

Weldment: _____

T-Column Quotation Worksheet

Special Request For Quotation:

If you have a requirement that can not be met with one of our standards, please do the following:

1. Photocopy this page and the previous page – if applicable – for an accurate quote.
2. Fill in the information concerning the product that will be quoted. Sketch in any information that is not provided, being as detailed as possible.
3. Mail or fax the RFQ sheet to TE-CO.
4. **Note: If ordered, this item will be manufactured directly from the information provided on this page. Please be sure information is correct. Authorized signature is required.**
5. Please draw in mounting holes or specification required for mounting to a pallet or machine table.
6. Please draw in any dimension holes needed in the face for fixtures. Be sure to include all information requested in the chart below.

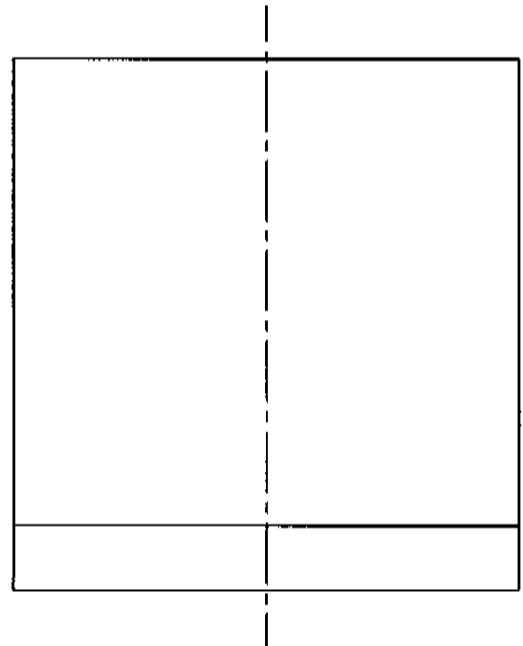
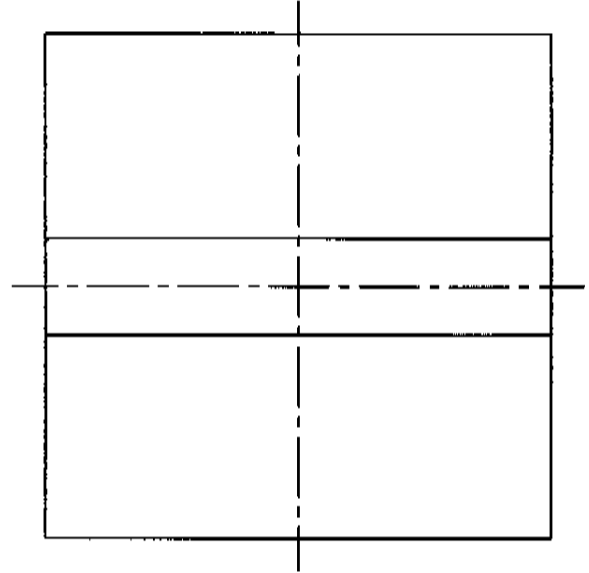

Hole Specifications					
	Hole Type	Hole Size	Hole Tolerance	Location Tolerance	Quantity of Holes
Ex:	Dowel	1/2"	±.0005	±.001	20
	1)				
	2)				
	3)				

Cut Corners on Base: (Specify size and angle)

Yes _____

No _____

Authorized Signature: _____ Date: _____

****Specials may require extended delivery time.**

