

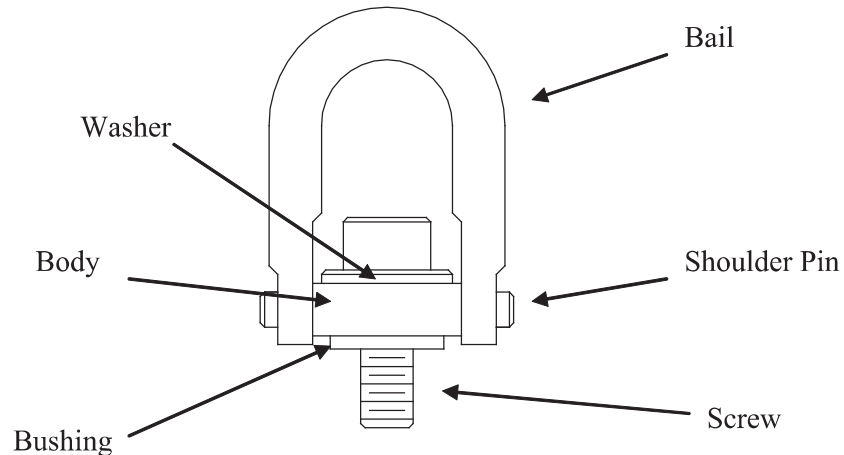

## HOIST RING INSPECTION & MAINTENANCE



### ALWAYS INSPECT THE HOIST RING BEFORE EACH USE. MAKE SURE:

- The screw is tightened to the recommended torque.
  - o If the screw is not tightened, the threads may be stripped on a vertical lift.
- The bushing of the hoist ring sits flush against the object being lifted.
  - o This ensures that the recommended torque puts the proper preload onto the hoist ring allowing the hoist ring to reach its full 5:1 safety factor.
- The hoist ring is free to swivel and pivot in every direction.
  - o If the hoist ring binds up in any direction, it should be removed from service.
- There are no signs of corrosion.
  - o This can cause deterioration to the hoist ring material allowing for fatigue or cracking to take place. Corrosion can also prevent the hoist ring from pivoting and swiveling freely.
- There are no signs of wear or cracks, especially on the screw, shoulder pins, and bail.
  - o Damage or wear on the screw head, shoulder pins, or bail may be an indication that the hoist ring is coming into contact with something during use. This should be avoided as such contact can cause binding and shock loads which exceed the rating of the hoist ring.
- The shoulder pins are secure and do not rotate or come loose.
  - o This can be checked by using pliers to rotate the shoulder pins by hand. If the shoulder pin does rotate, it is no longer securely in place and could come loose causing the hoist ring to break.



## HOIST RING INSPECTION & MAINTENANCE

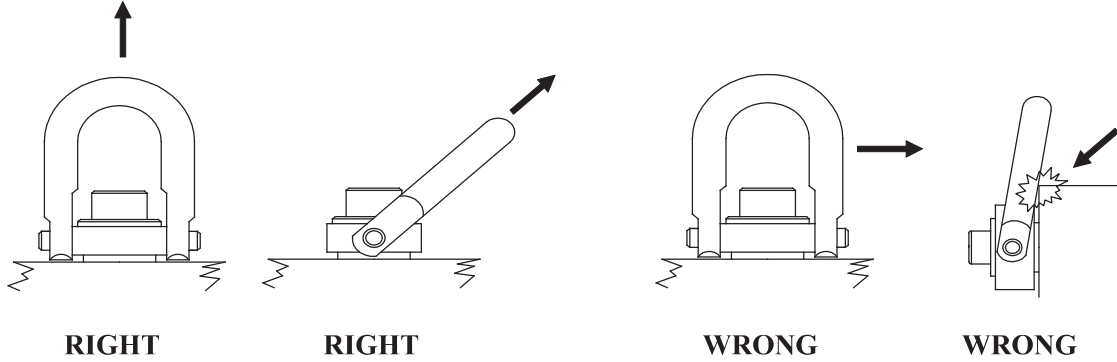

**Important:** The load on each hoist ring is not simply total weight divided by the number of hoist rings. The resultant force can be significantly greater at shallow lift angles and with unevenly distributed loads. See the example and chart below.

L = Load experienced by hoist ring  
 W = Total weight = 2,000 Lbs.

N = Number of hoist rings = 4  
 A = Lifting angle

$$L = \frac{W}{N \sin A}$$

If A = 60:  
 $L = \frac{2000}{4 \sin 60} = 577 \text{ Lbs.}$

If A = 20:  
 $L = \frac{2000}{4 \sin 20} = 1,462 \text{ Lbs.}$

Lifting Angle (Degrees)	Number of Hoist Rings	Weight of Load (Pounds)	Actual Applied Load on Hoist Ring (Pounds)
90	4	2,000	500
80	4	2,000	510
70	4	2,000	535
60	4	2,000	580
50	4	2,000	655
40	4	2,000	780
30	4	2,000	1,000
20	4	2,000	1,465

**GOOD**

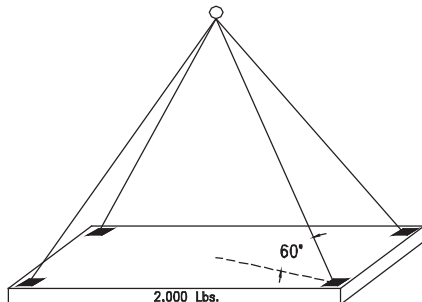

**BAD**

