

# CARVER CLAMPS

HOLDING POWER



## RACK AND BAR CLAMPS



# Rack Clamps

For tough jobs in engineering including

- Fabrication
- Welding
- Machining
- Maintenance
- Toolroom

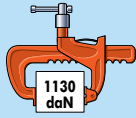
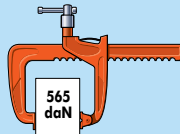
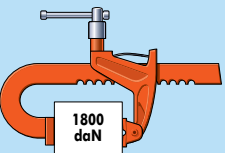
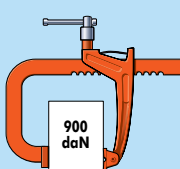
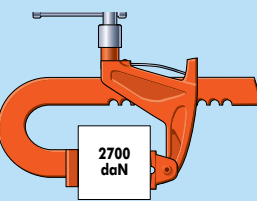

1 daN = 1 kgf  
1 daN = 2.2 lbf  
1 daN = 10 N

	Model No.	Capacity (S)		Reach (B1)	
		mm	Inch	mm	Inch
<b>Standard Duty</b> 	T186-150	150	(6)	60	(2 <sup>3</sup> / <sub>8</sub> )
	T186-300	300	(12)	60	(2 <sup>3</sup> / <sub>8</sub> )
	T186-500	500	(20)	60	(2 <sup>3</sup> / <sub>8</sub> )
	T186-750	750	(30)	60	(2 <sup>3</sup> / <sub>8</sub> )
<b>Standard Duty Long Reach</b> 	T321-250	250	(10)	120	(4 <sup>3</sup> / <sub>4</sub> )
	T321-600	600	(24)	120	(4 <sup>3</sup> / <sub>4</sub> )
<b>Medium Duty</b> 	T290-225	225	(9)	90	(3 <sup>1</sup> / <sub>2</sub> )
	T290-450	450	(18)	90	(3 <sup>1</sup> / <sub>2</sub> )
	T290-750	750	(30)	90	(3 <sup>1</sup> / <sub>2</sub> )
	T290-1000	1000	(40)	90	(3 <sup>1</sup> / <sub>2</sub> )
<b>Medium Duty Long Reach</b> 	T285-225	225	(9)	200	(8)
	T285-450	450	(18)	200	(8)
	T285-750	750	(30)	200	(8)
	T285-1000	1000	(40)	200	(8)
<b>Heavy Duty</b> 	T257-150	150	(6)	115	(4 <sup>1</sup> / <sub>2</sub> )
	T257-300	300	(12)	115	(4 <sup>1</sup> / <sub>2</sub> )
	T257-450	450	(18)	115	(4 <sup>1</sup> / <sub>2</sub> )
	T257-600	600	(24)	115	(4 <sup>1</sup> / <sub>2</sub> )
	T257-900	900	(36)	115	(4 <sup>1</sup> / <sub>2</sub> )
	T257-1350	1350	(54)	115	(4 <sup>1</sup> / <sub>2</sub> )



# CARVER CLAMPS

- Spring-loaded jaw stays in position when pressure removed.
- Jaw moves to security clamp angled surfaces.
- Working parts not exposed to weld spatter.
- No long screws to bend.
- Tightening action cannot rotate workpiece.

Overall Length		Weight kg
mm	Inch	
245	(9 <sup>5</sup> / <sub>8</sub> )	1.4
395	(15 <sup>1</sup> / <sub>2</sub> )	1.8
640	(25 <sup>1</sup> / <sub>8</sub> )	2.5
890	(35 <sup>1</sup> / <sub>8</sub> )	3.2
<hr/>		
360	(14 <sup>1</sup> / <sub>8</sub> )	2.0
715	(28 <sup>3</sup> / <sub>8</sub> )	3.5
<hr/>		
420	(16 <sup>1</sup> / <sub>2</sub> )	5.5
655	(25 <sup>3</sup> / <sub>4</sub> )	7.0
959	(37 <sup>3</sup> / <sub>4</sub> )	8.5
1216	(47 <sup>7</sup> / <sub>8</sub> )	10.5
<hr/>		
420	(16 <sup>1</sup> / <sub>2</sub> )	7.1
655	(25 <sup>3</sup> / <sub>4</sub> )	8.5
959	(37 <sup>3</sup> / <sub>4</sub> )	10.0
1216	(47 <sup>7</sup> / <sub>8</sub> )	11.5
<hr/>		
403	(15 <sup>7</sup> / <sub>8</sub> )	9.8
555	(21 <sup>7</sup> / <sub>8</sub> )	10.9
710	(27 <sup>3</sup> / <sub>4</sub> )	12.2
850	(33 <sup>1</sup> / <sub>2</sub> )	13.1
1165	(45 <sup>3</sup> / <sub>4</sub> )	15.8
1615	(63 <sup>1</sup> / <sub>2</sub> )	19.1

Model No.	Measurements in mm									
	A	A1	A2	B	B2	B3	B4	L	L1	
T186-150	25	13	76	32	43	33	76	245	20	
T186-300	25	13	76	32	43	33	76	395	20	
T186-500	25	13	76	35	43	30	76	625	30	
T186-750	25	13	76	35	43	30	76	875	30	
<hr/>										
T321-250	25	13	76	35	102	33,5	76	360	25	
T321-600	25	13	76	32	98	30	76	715	8	
<hr/>										
T290-225	40	20	140	60	65	40	105	420	65	
T290-450	40	20	140	60	65	40	105	655	65	
T290-750	40	20	140	60	65	40	105	955	65	
T290-1000	40	20	140	60	65	40	105	1205	65	
<hr/>										
T285-225	40	20	140	60	180	40	105	420	65	
T285-450	40	20	140	60	180	40	105	655	65	
T285-750	40	20	140	60	180	40	105	955	65	
T285-1000	40	20	140	60	180	40	105	1205	65	
<hr/>										
T257-150	51	22	187	60	85	51	127	403	100	
T257-300	51	22	187	60	85	51	127	555	100	
T257-450	51	22	187	60	85	51	127	710	100	
T257-600	51	22	187	60	85	51	127	850	100	
T257-900	51	22	187	60	85	51	127	1165	100	
T257-1350	51	22	187	60	85	51	127	1615	100	

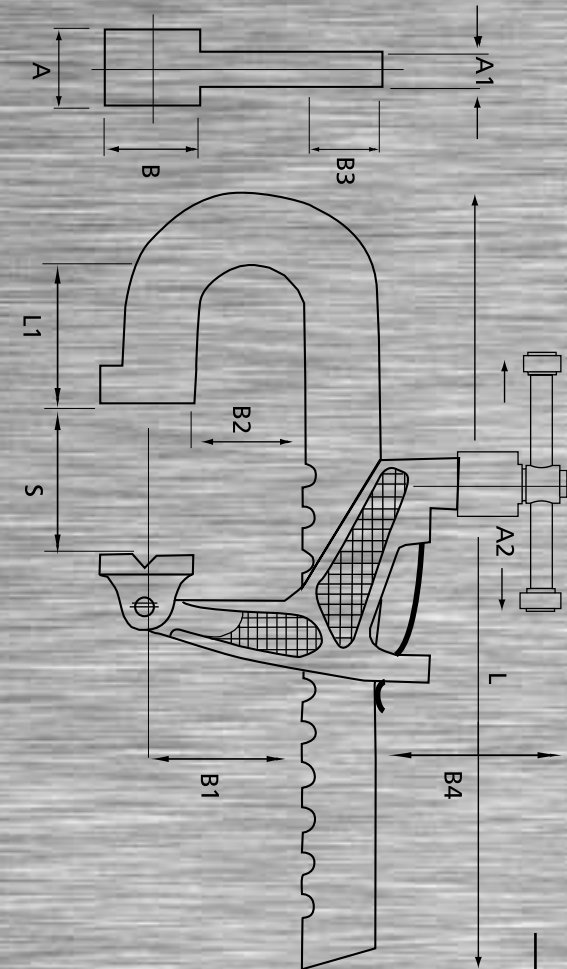

# Rack and Bar Clamps



For tough jobs in engineering including

- Fabrication
- Welding
- Machining
- Maintenance
- Toolroom

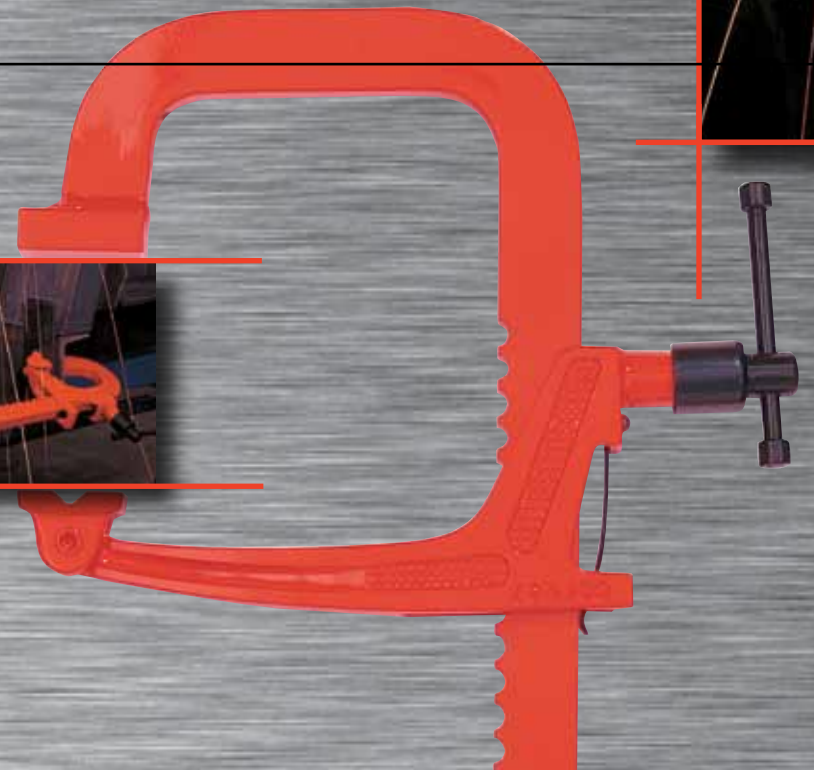



# CARVER CLAMPS

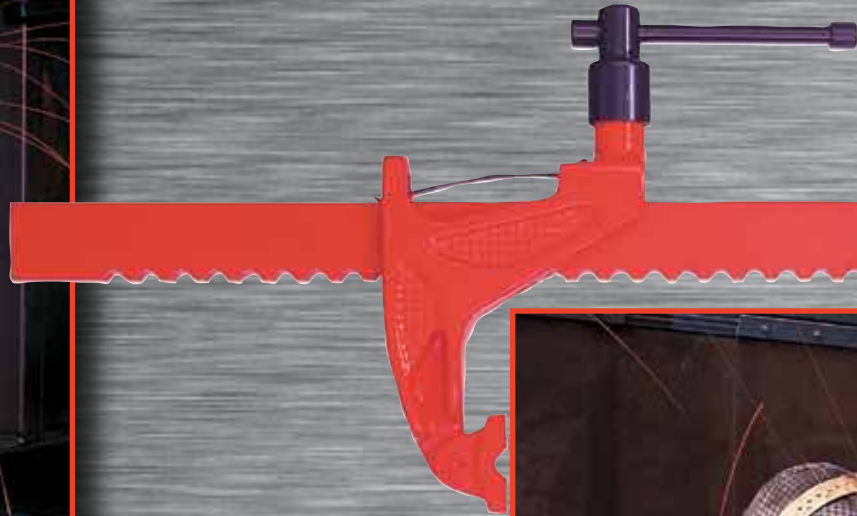



# Bar Clamps

For tough jobs in engineering including

- Fabrication
- Welding
- Machining
- Maintenance
- Toolroom

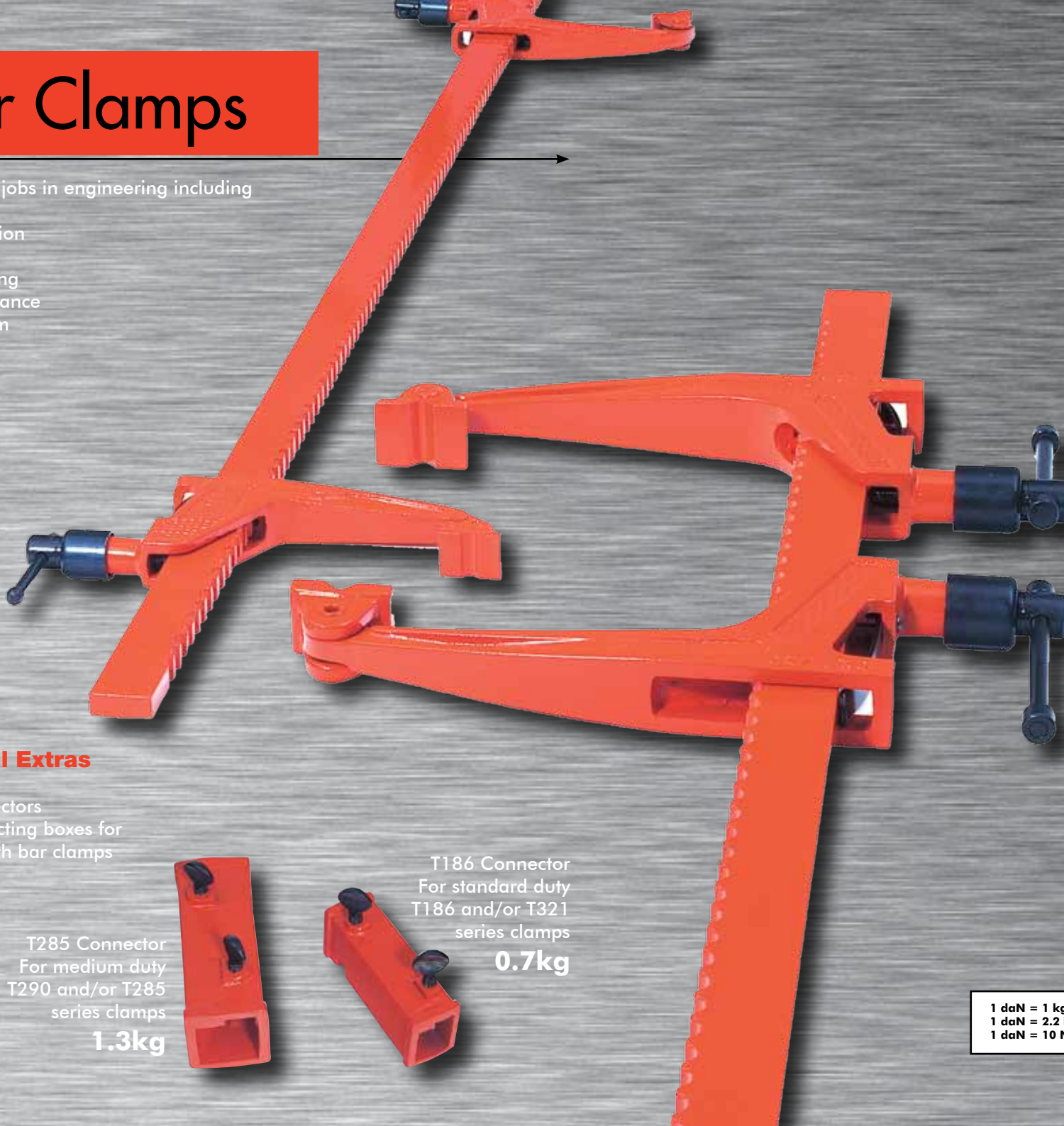

## Optional Extras

Bar Connectors  
Bar connecting boxes for extra length bar clamps

T285 Connector  
For medium duty  
T290 and/or T285  
series clamps  
**1.3kg**



T186 Connector  
For standard duty  
T186 and/or T321  
series clamps  
**0.7kg**



### Standard Duty

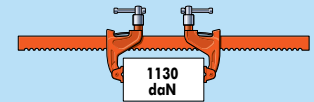

### Standard Duty Long Reach



### Medium Duty



### Medium Duty Long Reach

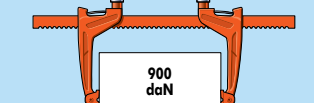

### Heavy Duty

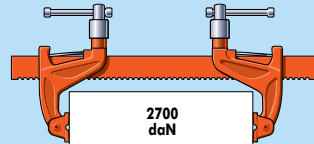

1 daN = 1 kgf  
1 daN = 2.2 lbf  
1 daN = 10 N

- Spring-loaded jaw stays in position when pressure removed.
- Jaw moves to security clamp angled surfaces.
- Simple reverse jaws for a spreading action.
- Working parts not exposed to weld spatter.
- No long screws to bend.
- Tightening action cannot rotate workpiece.

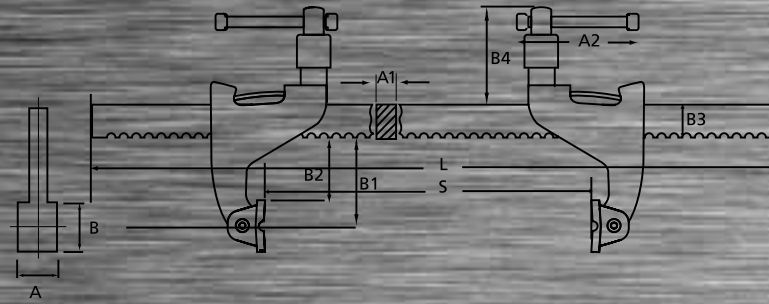

# CARVER CLAMPS

Model No.	Capacity (S)		Reach (B1)		Weight kg
	mm	Inch	mm	Inch	
T186-600	600	(24)	60	(2 3/4)	3.4
T186-900	900	(36)	60	(2 3/4)	4.4
T186-1500	1500	(60)	60	(2 3/4)	5.8
T186-2100	2100	(84)	60	(2 3/4)	7.6
T186-2400	2400	(96)	60	(2 3/4)	8.8
T321-600	600	(24)	120	(4 3/4)	3.5
T321-900	900	(36)	120	(4 3/4)	4.5
T321-1500	1500	(60)	120	(4 3/4)	5.9
T321-2100	2100	(84)	120	(4 3/4)	7.7
T321-2400	2400	(96)	120	(4 3/4)	8.9
T290-900	900	(36)	90	(3 1/2)	10.5
T290-1200	1200	(48)	90	(3 1/2)	12.1
T290-1500	1500	(60)	90	(3 1/2)	14.0
T290-2100	2100	(84)	90	(3 1/2)	18.0
T285-900	900	(36)	200	(8)	11.5
T285-1200	1200	(48)	200	(8)	13.0
T285-1500	1500	(60)	200	(8)	15.0
T285-2100	2100	(84)	200	(8)	19.0
T257-2100	2100	(84)	115	(4 1/2)	27.2
T257-2700	2700	(108)	115	(4 1/2)	32.0

Model No.	Measurements in mm							
	A	A1	A2	B	B2	B3	B4	L
T186-600	25	12	76	32	44	30	76	710
T186-900	25	12	76	32	44	30	76	1020
T186-1500	25	12	76	32	44	30	76	1625
T186-2100	25	12	76	32	44	30	76	2235
T186-2400	25	12	76	32	44	30	76	2540
T321-600	25	12	76	32	104	30	76	710
T321-900	25	12	76	32	104	30	76	1020
T321-1500	25	12	76	32	104	30	76	1625
T321-2100	25	12	76	32	104	30	76	2235
T321-2400	25	12	76	32	104	30	76	2540
T290-900	38	20	140	51	65	40	105	1070
T290-1200	38	20	140	51	65	40	105	1390
T290-1500	38	20	140	51	65	40	105	1690
T290-2100	38	20	140	51	65	40	105	2290
T285-900	38	20	140	51	180	40	105	1070
T285-1200	38	20	140	51	180	40	105	1390
T285-1500	38	20	140	51	180	40	105	1690
T285-2100	38	20	140	51	180	40	105	2290
T257-2100	51	22	187	63,5	83	52	127	2335
T257-2700	51	22	187	63,5	83	52	127	2945



Specifications are subject to review and improvement.  
Data in this publication is for information only and does not form part of any contract.