

# NC BLOCK COMPONENTS INDEX

PAGE	DATE	NAAMS CODE	DESCRIPTION
<a href="#">0-1</a>	02/12/14		NC Block Components Index
<a href="#">0-1.1</a>	02/12/14		NC Block Components Index
<a href="#">0-2</a>	02/12/14	ANI080 – ANI083	NC Blocks Blanks, I-Shaped, 3-Hole x 80
<a href="#">0-3</a>	02/12/14	ANI084 – ANI087	NC Blocks Blanks, I-Shaped, 4-Hole x 80
<a href="#">0-4</a>	02/12/14	ANI120 – ANI123	NC Blocks Blanks, I-Shaped, 3-Hole x 120
<a href="#">0-5</a>	02/12/14	ANI126 – ANI129	NC Blocks Blanks, I-Shaped, 4-Hole x 120
<a href="#">0-6</a>	02/12/14	ANL060 – ANL061	NC Blocks Blanks, L-Shaped, 3-Hole x 60
<a href="#">0-7</a>	02/12/14	ANL062 – ANL063	NC Blocks Blanks, L-Shaped, 3-Hole x 60
<a href="#">0-8</a>	02/12/14	ANL064 – ANL065	NC Blocks Blanks, L-Shaped, 4-Hole x 60
<a href="#">0-9</a>	02/12/14	ANL066 – ANL067	NC Blocks Blanks, L-Shaped, 4-Hole x 60
<a href="#">0-10</a>	02/12/14	ANL100 – ANL101	NC Blocks Blanks, L-Shaped, 3-Hole x 100
<a href="#">0-11</a>	02/12/14	ANL102 – ANL103	NC Blocks Blanks, L-Shaped, 3-Hole x 100
<a href="#">0-12</a>	02/12/14	ANL104 – ANL105	NC Blocks Blanks, L-Shaped, 4-Hole x 100
<a href="#">0-13</a>	02/12/14	ANL106 – ANL107	NC Blocks Blanks, L-Shaped, 4-Hole x 100
<a href="#">0-14</a>	02/12/14	ANR130 – ANR137	NC Blocks Blanks, Rectangular, 3-Hole
<a href="#">0-15</a>	02/12/14	ANR140 – ANR147	NC Blocks Blanks, Rectangular, 4-Hole
<a href="#">0-16</a>	02/12/14	ANR230 – ANR233	NC Blocks Blanks, Rectangular, 3-Hole
<a href="#">0-17</a>	02/12/14	ANR240 – ANR243	NC Blocks Blanks, Rectangular, 4-Hole
<a href="#">0-18</a>	07/25/08	ANI381 – ANI383 ANI391 – ANI392	NC Blocks Blanks, I-Shaped, 3-Hole x 80, 20 mm
<a href="#">0-19</a>	02/12/14	ANI384 – ANI387	NC Blocks Blanks, I-Shaped, 4-Hole x 80, 20 mm
<a href="#">0-20</a>	07/25/08	ANI421 – ANI425	NC Blocks Blanks, I-Shaped, 3-Hole x 120, 20 mm
<a href="#">0-21</a>	02/12/14	ANI426 – ANI429	NC Blocks Blanks, I-Shaped, 4-Hole x 120, 20 mm
<a href="#">0-22</a>	07/25/08	ANL361 – ANL363 ANL368 – ANL369	NC Blocks Blanks, L-Shaped, 3-Hole x 60, 20 mm
<a href="#">0-23</a>	02/12/14	ANL364 – ANL365	NC Blocks Blanks, L-Shaped, 4-Hole x 60, 20 mm
<a href="#">0-24</a>	02/12/14	ANL366 – ANL367	NC Blocks Blanks, L-Shaped, 4-Hole x 60, 20 mm
<a href="#">0-25</a>	07/25/08	ANL401 – ANL403 ANL408 – ANL409	NC Blocks Blanks, L-Shaped, 3-Hole x 100, 20 mm
<a href="#">0-26</a>	02/12/14	ANL404 – ANL405	NC Blocks Blanks, L-Shaped, 4-Hole x 100, 20 mm
<a href="#">0-27</a>	02/12/14	ANL406 – ANL407	NC Blocks Blanks, L-Shaped, 4-Hole x 100, 20 mm
<a href="#">0-28</a>	07/25/08	ANR431 – ANR437 ANR448 – ANR451	NC Blocks Blanks, Rectangular, 3-Hole, 20 mm
<a href="#">0-29</a>	02/12/14	ANR440 – ANR447	NC Blocks Blanks, Rectangular, 4-Hole, 20 mm
<a href="#">0-30</a>	07/25/08	ANR531 – ANR535	NC Blocks Blanks, Rectangular, 3-Hole, 20 mm
<a href="#">0-31</a>	02/12/14	ANR540 – ANR543	NC Blocks Blanks, Rectangular, 4-Hole, 20 mm

# NC BLOCK COMPONENTS INDEX

<b>PAGE</b>	<b>DATE</b>	<b>NAAMS CODE</b>	<b>DESCRIPTION</b>
<a href="#">0-32</a>	02/12/14	ANI206 - ANI209	NC BLANKS 20mm SERIES
<a href="#">0-33</a>	02/12/14	ANI201 - ANI204	NC BLANKS 20mm SERIES
<a href="#">0-34</a>	02/12/14	ANI216 - ANI219	NC BLANKS 20mm SERIES
<a href="#">0-35</a>	02/12/14	ANI211 - ANI214	NC BLANKS 20mm SERIES
<a href="#">0-36</a>	02/12/14	ANL215 - ANL218	NC BLANKS 20mm SERIES
<a href="#">0-37</a>	02/12/14	ANL211 - ANL212	NC BLANKS 20mm SERIES
<a href="#">0-38</a>	02/12/14	ANL221 - ANL222	NC BLANKS 20mm SERIES
<a href="#">0-39</a>	02/12/14	ANL225 - ANL228	NC BLANKS 20mm SERIES
<a href="#">0-40</a>	02/12/14	ANL311 - ANL312	NC BLANKS 20mm SERIES
<a href="#">0-41</a>	02/12/14	ANL411 - ANL412	NC BLANKS 20mm SERIES
<a href="#">0-42</a>	02/12/14	ANR600 - ANR607	NC BLANKS 20mm SERIES
<a href="#">0-43</a>	02/12/14	ANR301 - ANR308	NC BLANKS 20mm SERIES
<a href="#">0-44</a>	02/12/14	ANR320 - ANR323	NC BLANKS 20mm SERIES
<a href="#">0-45</a>	02/12/14	ANR311 - ANR314	NC BLANKS 20mm SERIES

# NC BLOCK BLANKS ANR130 THRU 137

Tolerances: METRIC

- 1 PLACE  $\pm 0.3$
- 2 PLACE  $\pm 0.03$
- 3 PLACE  $\pm 0.020$

 SURFACES TO BE FLAT, PARALLEL & PERPENDICULAR TO WITHIN 0.015 T.I.R.

MATERIAL: STEEL

NOTE: Identify with NAAMS CODE number as shown **XXX**.

Black Oxide Finish

No Black Oxide Finish to "SS Type" Components

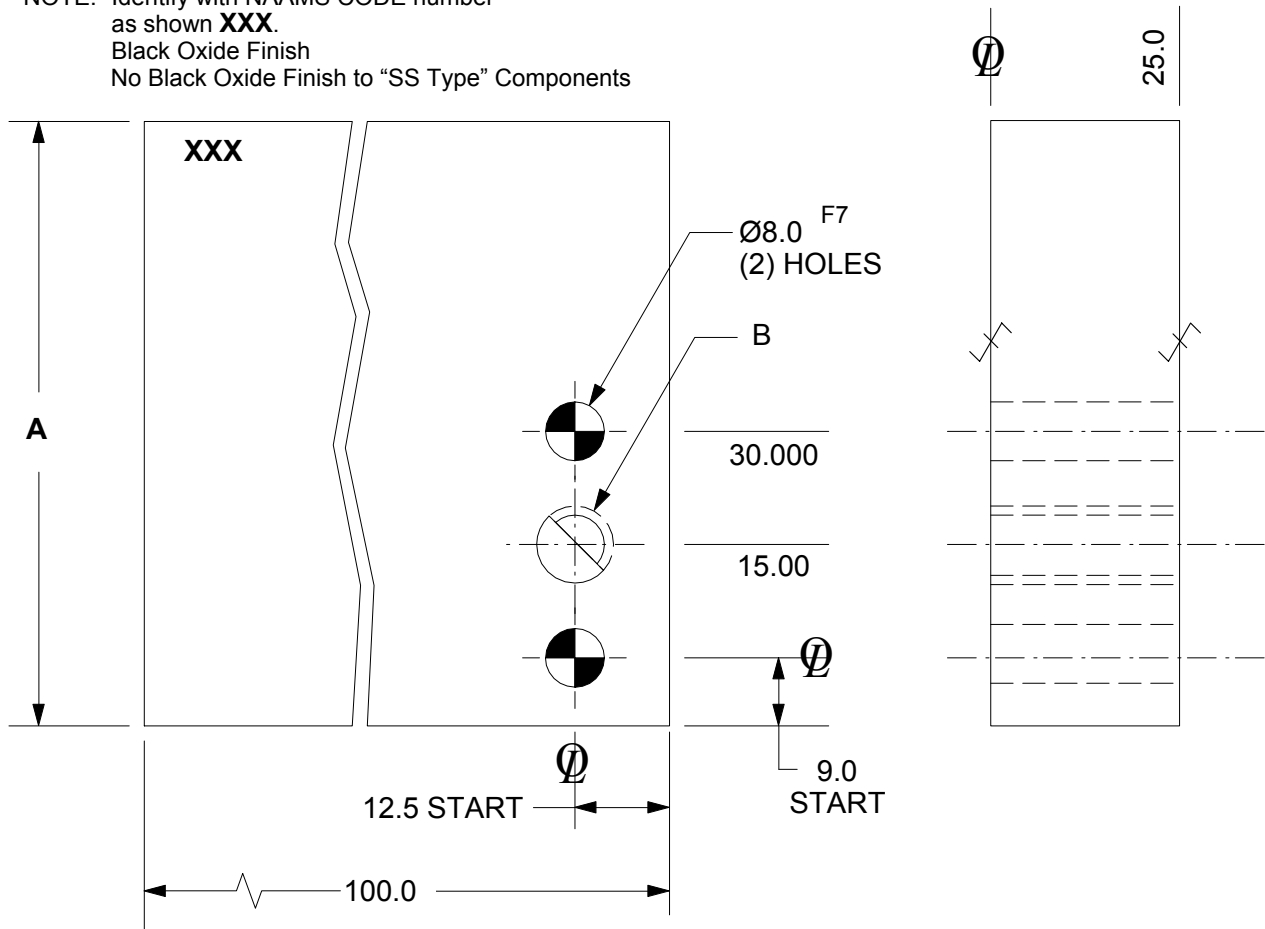

SEE PAGE B-1.1 FOR GLOBAL MATERIALS CHART

NAAMS CODE	A	B	MATERIAL	WT. kg
ANR130	80.0	M10 X 1.5	STEEL SAE 4140	1.5
ANR131	80.0	M10 X 1.5	SS type 303 or 304	1.5
ANR132	80.0	$\varnothing 11.0$	STEEL SAE 4140	1.5
ANR133	80.0	$\varnothing 11.0$	SS type 303 or 304	1.5
ANR134	120.0	M10 X 1.5	STEEL SAE 4140	2.3
ANR135	120.0	M10 X 1.5	SS type 303 or 304	2.3
ANR136	120.0	$\varnothing 11.0$	STEEL SAE 4140	2.3
ANR137	120.0	$\varnothing 11.0$	SS type 303 or 304	2.3

D

C

A

B

# NC BLOCK BLANKS ANR140 THRU 147

GLOBAL STANDARD COMPONENTS



Assembly

02/12/14

Tolerances: METRIC

1 PLACE  $\pm 0.3$

2 PLACE  $\pm 0.03$

3 PLACE  $\pm 0.020$

✓ SURFACES TO BE FLAT, PARALLEL & PERPENDICULAR TO WITHIN 0.015 T.I.R.

MATERIAL: STEEL

NOTE: Identify with NAAMS CODE number as shown **XXX**.

Black Oxide Finish

No Black Oxide Finish to "SS Type" Components

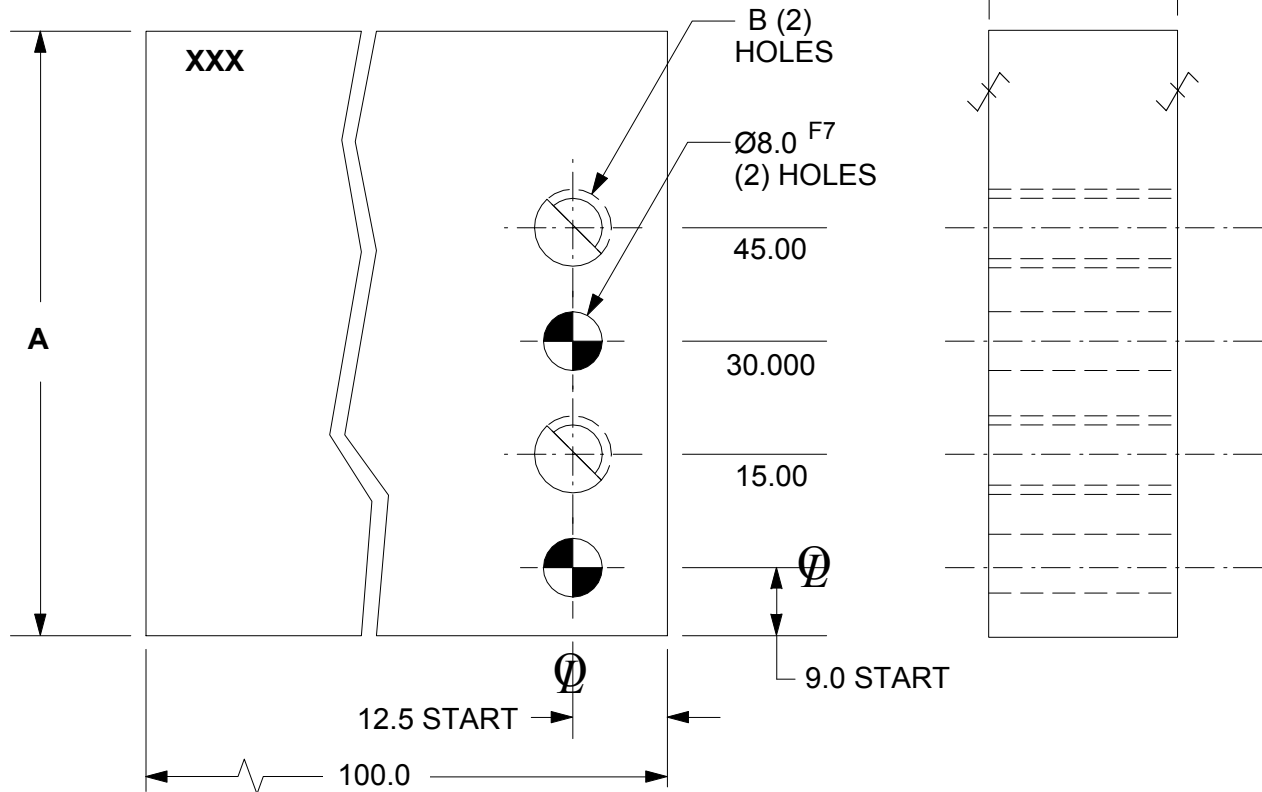

D

SEE PAGE B-1.1 FOR GLOBAL MATERIALS CHART

NAAMS CODE	A	B	MATERIAL	WT. kg
ANR140	80.0	M10 X 1.5	STEEL SAE 4140	1.5
ANR141	80.0	M10 X 1.5	SS type 303 or 304	1.5
ANR142	80.0	Ø11.0	STEEL SAE 4140	1.5
ANR143	80.0	Ø11.0	SS type 303 or 304	1.5
ANR144	120.0	M10 X 1.5	STEEL SAE 4140	2.3
ANR145	120.0	M10 X 1.5	SS type 303 or 304	2.3
ANR146	120.0	Ø11.0	STEEL SAE 4140	2.3
ANR147	120.0	Ø11.0	SS type 303 or 304	2.3

C  
A  
B

# NC BLOCK BLANKS ANR230 THRU 233

Tolerances: METRIC

- 1 PLACE  $\pm 0.3$
- 2 PLACE  $\pm 0.03$
- 3 PLACE  $\pm 0.020$

 SURFACES TO BE FLAT, PARALLEL & PERPENDICULAR TO WITHIN 0.015 T.I.R.

MATERIAL: STEEL

NOTE: Identify with NAAMS CODE number as shown **XXX**.

Black Oxide Finish

No Black Oxide Finish to "SS Type" Components

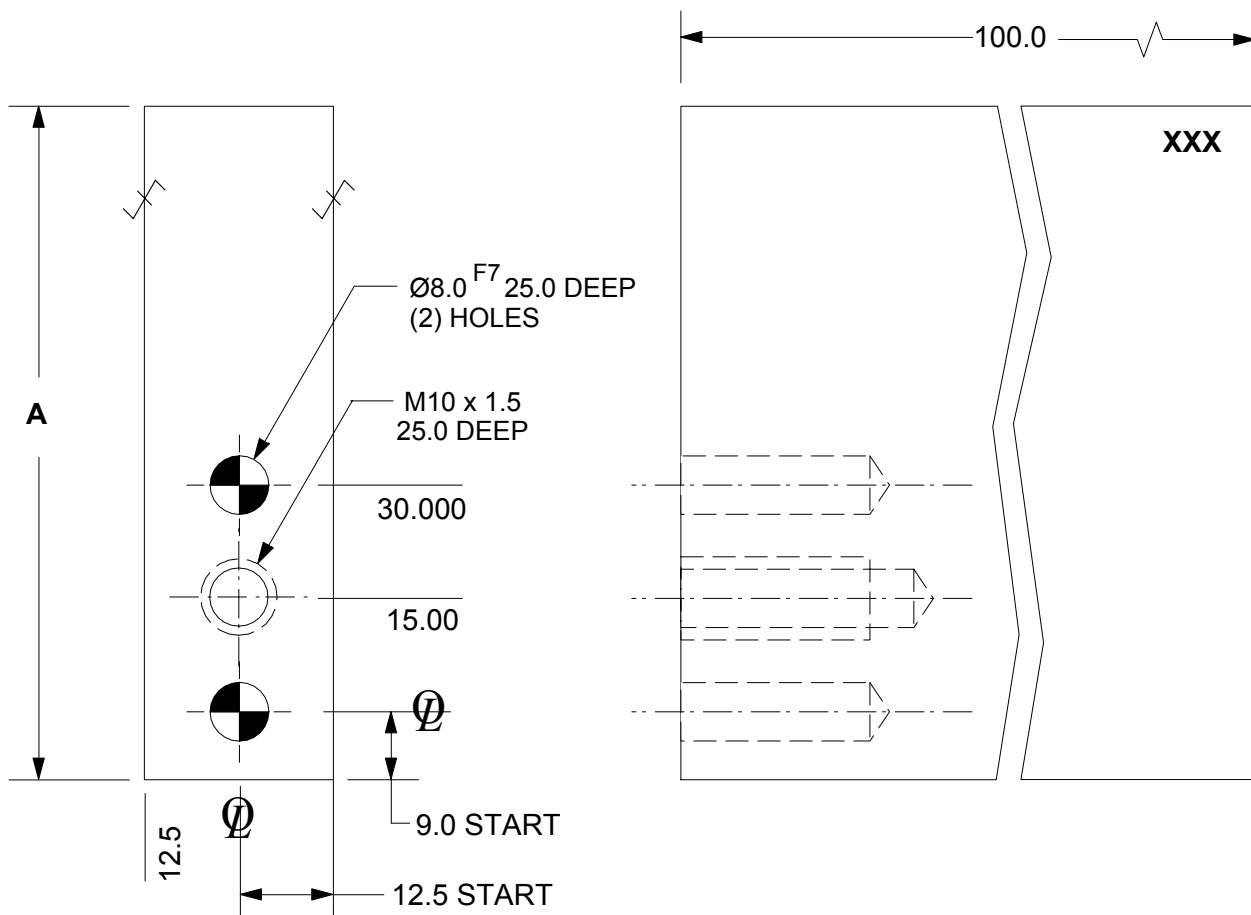

SEE PAGE B-1.1 FOR GLOBAL MATERIALS CHART

NAAMS CODE	A	MATERIAL	WT. kg
ANR230	80.0	STEEL SAE 4140	1.5
ANR231	80.0	SS type 303 or 304	1.5
ANR232	120.0	STEEL SAE 4140	2.3
ANR233	120.0	SS type 303 or 304	2.3

D

C  
A  
B

# NC BLOCK BLANKS ANR240 THRU 243

GLOBAL STANDARD COMPONENTS



Assembly

02/12/14

Tolerances: METRIC

- 1 PLACE  $\pm 0.3$
- 2 PLACE  $\pm 0.03$
- 3 PLACE  $\pm 0.020$

SURFACES TO BE FLAT, PARALLEL & PERPENDICULAR TO WITHIN 0.015 T.I.R.

MATERIAL: STEEL

NOTE: Identify with NAAMS CODE number as shown **XXX**.

Black Oxide Finish

No Black Oxide Finish to "SS Type" Components

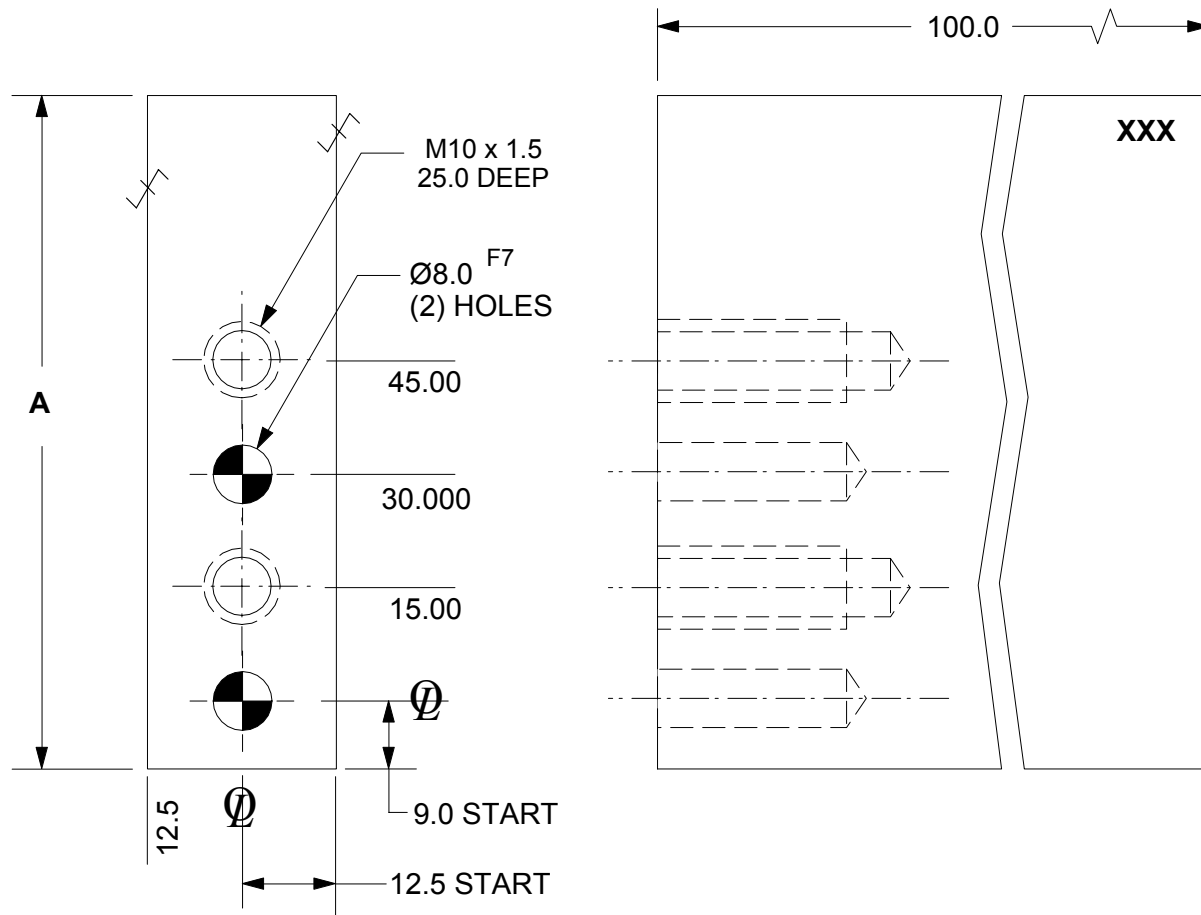

D

SEE PAGE B-1.1 FOR GLOBAL MATERIALS CHART

NAAMS CODE	A	MATERIAL	WT. kg
ANR240	80.0	STEEL SAE 4140	1.5
ANR241	80.0	SS type 303 or 304	1.5
ANR242	120.0	STEEL SAE 4140	2.3
ANR243	120.0	SS type 303 or 304	2.3

C  
A  
B

# NC BLOCK BLANKS

## 20 mm SERIES

### ANR431,433,435.437,448-451

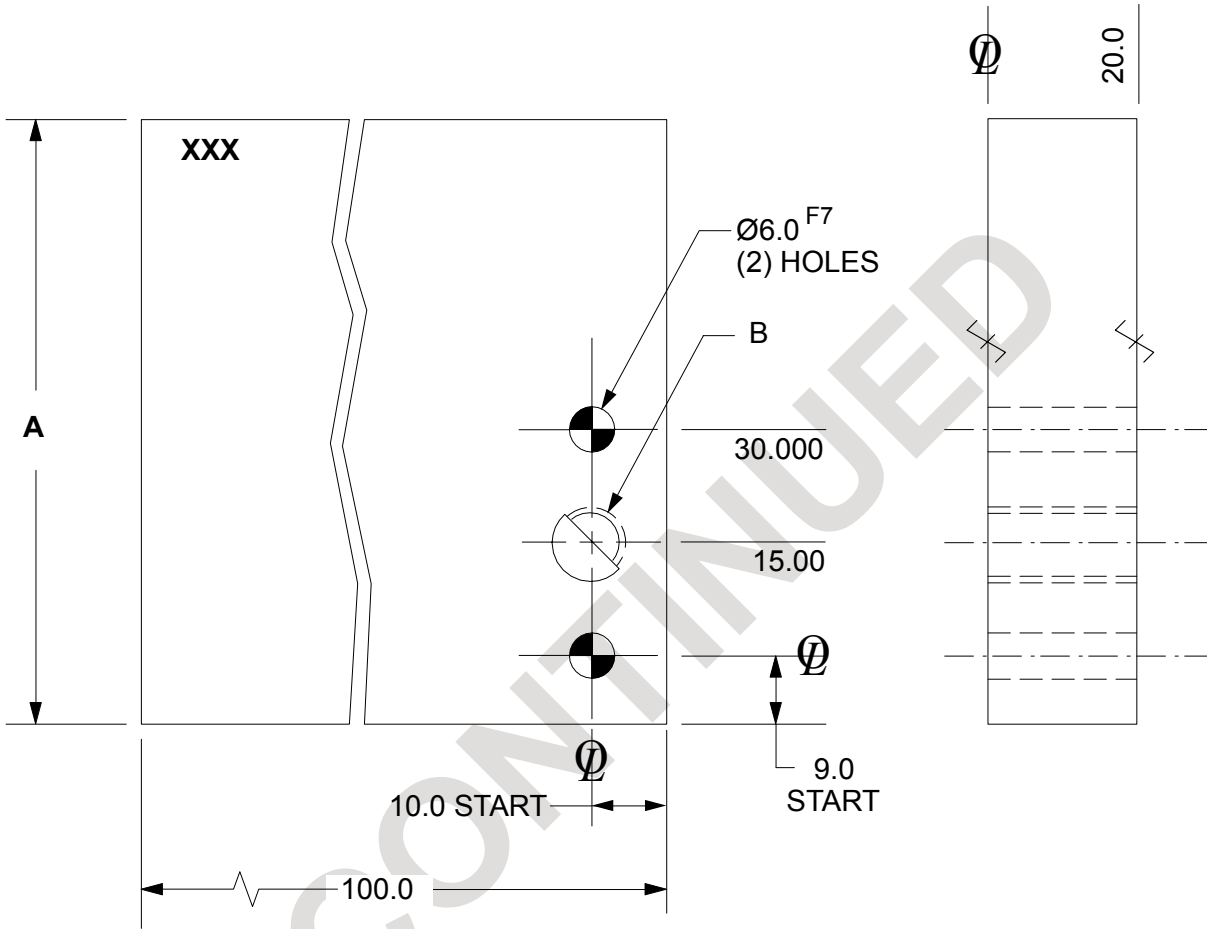

SEE PAGE B-1.1 FOR GLOBAL MATERIALS CHART

NAAMS CODE	A	B	MATERIAL	WT. kg
ANR448	80.0	M8 x 1.25	STEEL SAE 4140	1.2
ANR431	80.0	M8 x 1.25	SS type 303 or 304	1.2
ANR449	80.0	Ø 9.0	STEEL SAE 4140	1.2
ANR433	80.0	Ø 9.0	SS type 303 or 304	1.2
ANR450	120.0	M8 x 1.25	STEEL SAE 4140	1.9
ANR435	120.0	M8 x 1.25	SS type 303 or 304	1.9
ANR451	120.0	Ø 9.0	STEEL SAE4140	1.9
ANR437	120.0	Ø 9.0	SS type 303 or 304	1.9

Tolerances:

- 1 PLACE ± 0.3
- 2 PLACE ± 0.03
- 3 PLACE ± 0.020

∩ SURFACES TO BE FLAT, PARALLEL & PERPENDICULAR TO WITHIN 0.015 T.I.R.

NOTE: Identify with NAAMS CODE number as shown **XXX**.  
Black Oxide Finish

E

D

A

B

C

# NC BLOCK BLANKS

## 20 mm SERIES

### ANR440 THRU 447

Tolerances:

- 1 PLACE  $\pm 0.3$
- 2 PLACE  $\pm 0.03$
- 3 PLACE  $\pm 0.020$

 SURFACES TO BE FLAT, PARALLEL & PERPENDICULAR TO WITHIN 0.015 T.I.R.

NOTE: Identify with NAAMS CODE number as shown **XXX**.  
 Black Oxide Finish  
 No Black Oxide Finish to "SS Type" Components

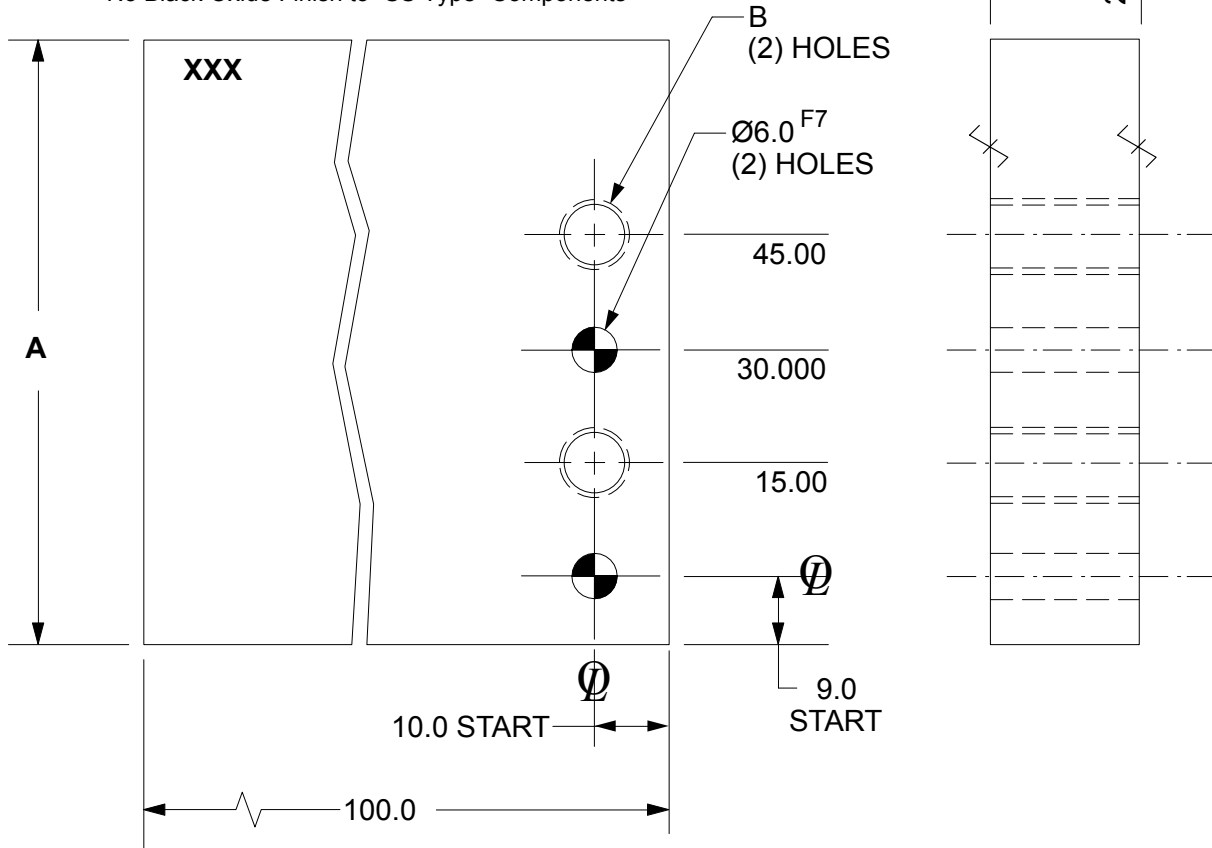

D

SEE PAGE B-1.1 FOR GLOBAL MATERIALS CHART

NAAMS CODE	A	B	MATERIAL	WT. kg
ANR440	80.0	M8 x 1.25	STEEL SAE 4140	1.2
ANR441	80.0	M8 x 1.25	SS type 303 or 304	1.2
ANR442	80.0	$\varnothing 9.0$	STEEL SAE 4140	1.2
ANR443	80.0	$\varnothing 9.0$	SS type 303 or 304	1.2
ANR444	120.0	M8 x 1.25	STEEL SAE 4140	1.9
ANR445	120.0	M8 x 1.25	SS type 303 or 304	1.9
ANR446	120.0	$\varnothing 9.0$	STEEL SAE 4140	1.9
ANR447	120.0	$\varnothing 9.0$	SS type 303 or 304	1.9

C  
A  
B



# NC BLOCK BLANKS

## 20 mm SERIES

### ANR531,533,534,535

Tolerances:

- 1 PLACE  $\pm 0.3$
- 2 PLACE  $\pm 0.03$
- 3 PLACE  $\pm 0.020$

 SURFACES TO BE FLAT, PARALLEL & PERPENDICULAR TO WITHIN 0.015 T.I.R.

NOTE: Identify with NAAMS CODE number as shown **XXX**.  
 Black Oxide Finish

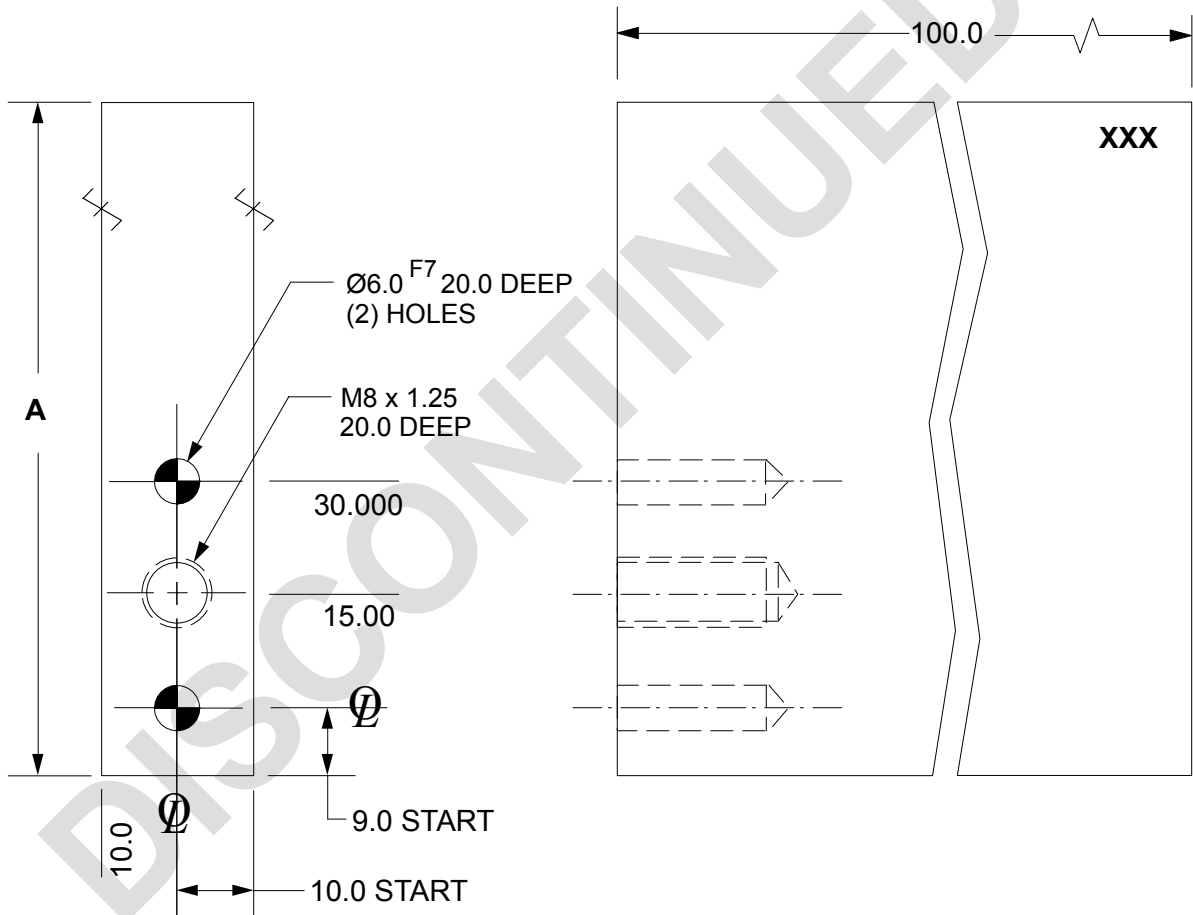

E

SEE PAGE B-1.1 FOR GLOBAL MATERIALS CHART

NAAMS CODE	A	MATERIAL	WT. kg
ANR534	80.0	STEEL SAE 4140	1.2
ANR531	80.0	SS type 303 or 304	1.2
ANR535	120.0	STEEL SAE 4140	1.9
ANR533	120.0	SS type 303 or 304	1.9

D  
A  
B  
C

# NC BLOCK BLANKS

## 20 mm SERIES

### ANR540 THRU 543

Tolerances:

- 1 PLACE  $\pm 0.3$
- 2 PLACE  $\pm 0.03$
- 3 PLACE  $\pm 0.020$

 SURFACES TO BE FLAT, PARALLEL & PERPENDICULAR TO WITHIN 0.015 T.I.R.

NOTE: Identify with NAAMS CODE number as shown **XXX**.

Black Oxide Finish

No Black Oxide Finish to "SS Type" Components

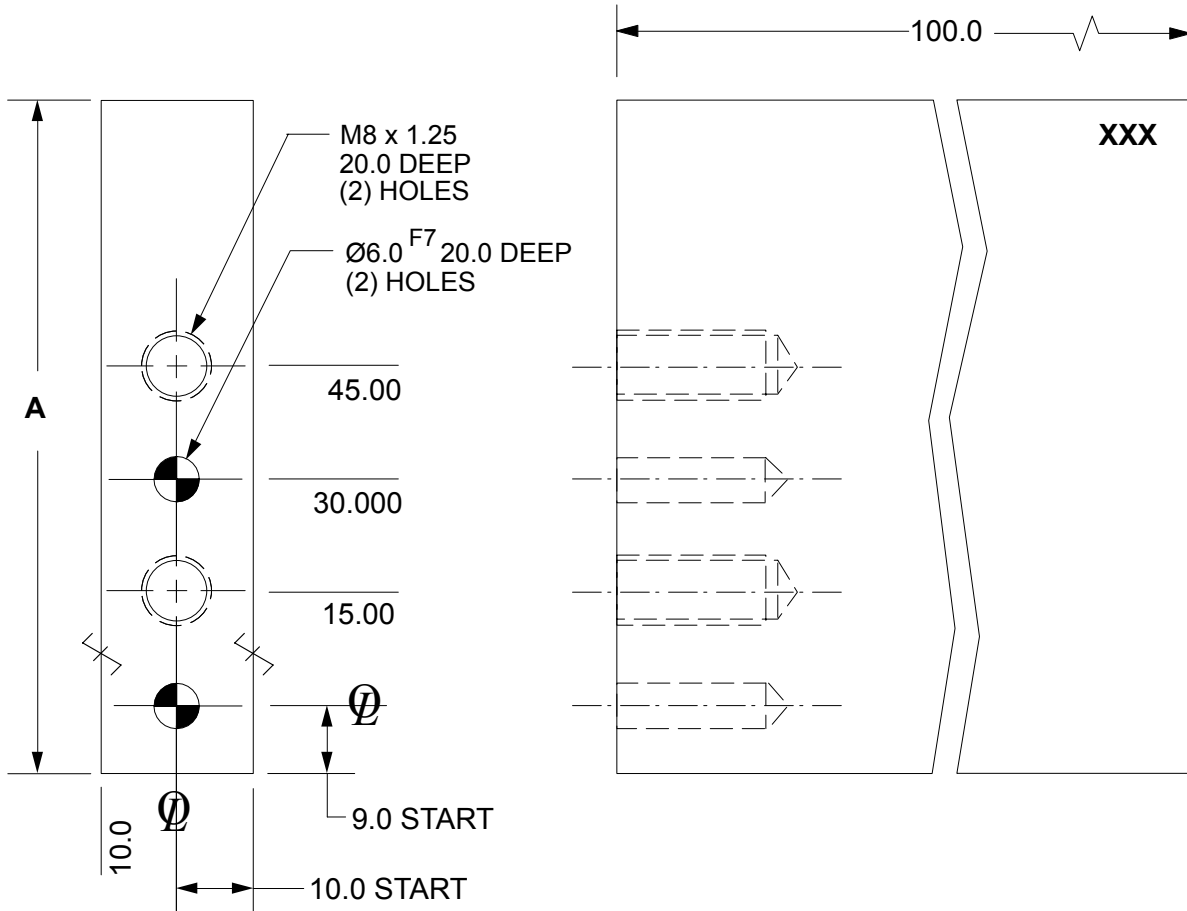

SEE PAGE B-1.1 FOR GLOBAL MATERIALS CHART

NAAMS CODE	A	MATERIAL	WT. kg
ANR540	80.0	STEEL SAE 4140	1.2
ANR541	80.0	SS type 303 or 304	1.2
ANR542	120.0	STEEL SAE 4140	1.9
ANR543	120.0	SS type 303 or 304	1.9

D

C  
A  
B

# NC BLOCK BLANKS 20 mm SERIES ANR600 THRU ANR607

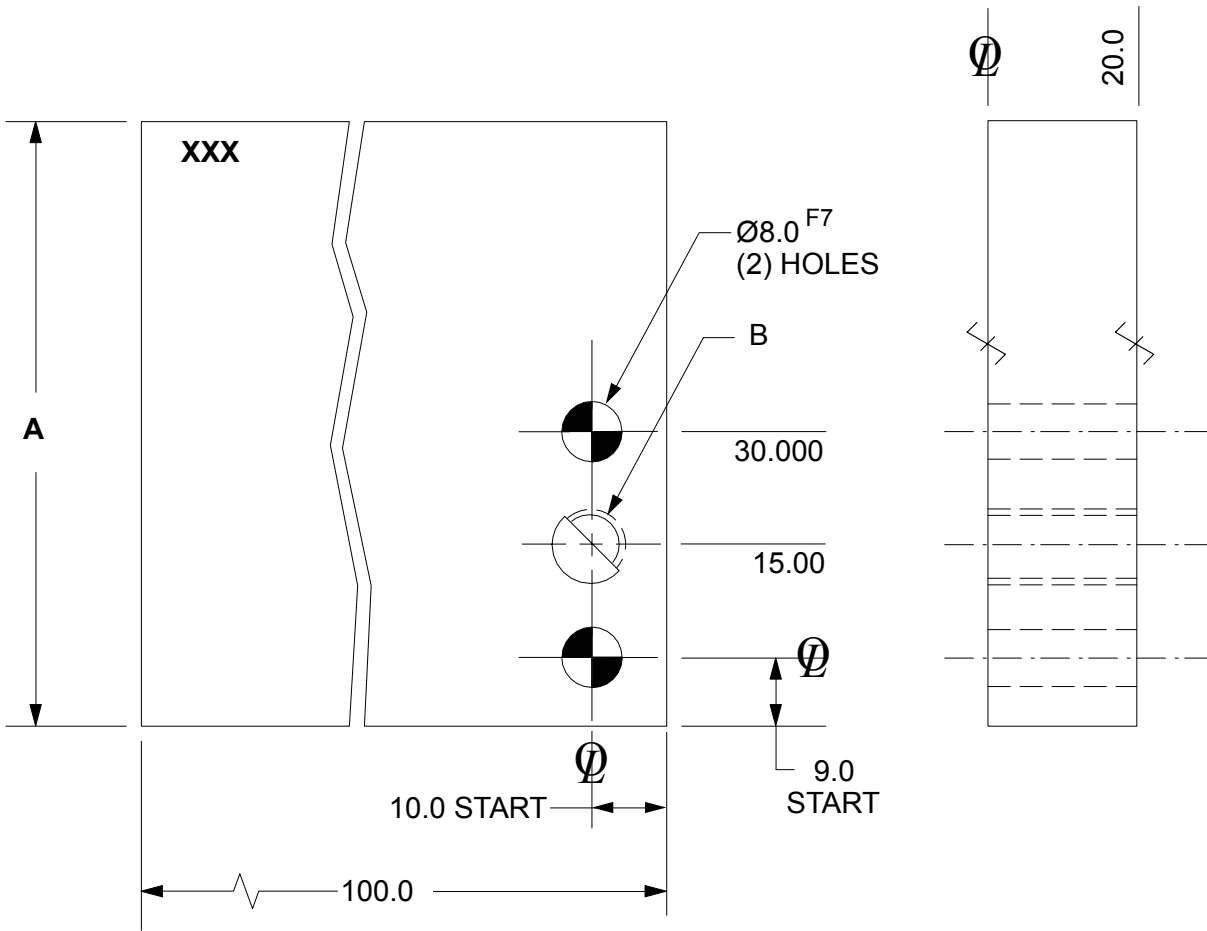

SEE PAGE B-1.1 FOR GLOBAL MATERIALS CHART

NAAMS CODE	A	B	MATERIAL	WT. kg
ANR600	80.0	M8 x 1.25	STEEL SAE 4140	1.2
ANR601	80.0	M8 x 1.25	SS type 303 or 304	1.2
ANR602	80.0	$\varnothing 9.0$	STEEL SAE 4140	1.2
ANR603	80.0	$\varnothing 9.0$	SS type 303 or 304	1.2
ANR604	120.0	M8 x 1.25	STEEL SAE 4140	1.9
ANR605	120.0	M8 x 1.25	SS type 303 or 304	1.9
ANR606	120.0	$\varnothing 9.0$	STEEL SAE4140	1.9
ANR607	120.0	$\varnothing 9.0$	SS type 303 or 304	1.9

Tolerances:

- 1 PLACE  $\pm 0.3$
- 2 PLACE  $\pm 0.03$
- 3 PLACE  $\pm 0.020$

 SURFACES TO BE FLAT, PARALLEL & PERPENDICULAR TO WITHIN 0.015 T.I.R.

NOTE: Identify with NAAMS CODE number as shown **XXX**.  
Black Oxide Finish

No Black Oxide Finish to "SS Type" Components

**A**

# NC BLOCK BLANKS 20 mm SERIES ANR301 THRU ANR308

Tolerances:

- 1 PLACE  $\pm 0.3$
- 2 PLACE  $\pm 0.03$
- 3 PLACE  $\pm 0.020$

 SURFACES TO BE FLAT, PARALLEL & PERPENDICULAR TO WITHIN 0.015 T.I.R.

NOTE: Identify with NAAMS CODE number as shown **XXX**.  
Black Oxide Finish  
No Black Oxide Finish to "SS Type" Components

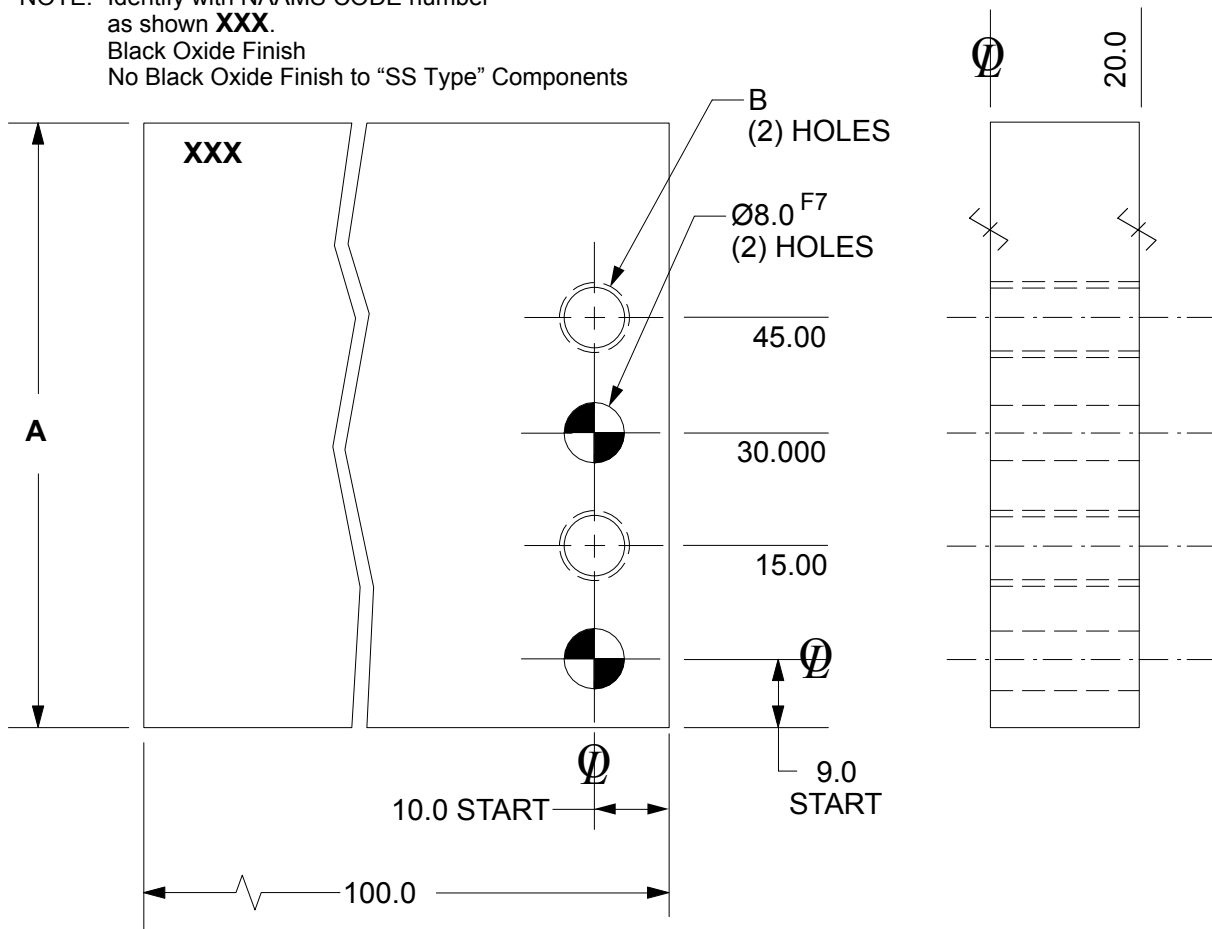

**A**

SEE PAGE B-1.1 FOR GLOBAL MATERIALS CHART

NAAMS CODE	A	B	MATERIAL	WT. kg
ANR301	80.0	M8 x 1.25	STEEL SAE 4140	1.2
ANR302	80.0	M8 x 1.25	SS type 303 or 304	1.2
ANR303	80.0	$\varnothing 9.0$	STEEL SAE 4140	1.2
ANR304	80.0	$\varnothing 9.0$	SS type 303 or 304	1.2
ANR305	120.0	M8 x 1.25	STEEL SAE 4140	1.9
ANR306	120.0	M8 x 1.25	SS type 303 or 304	1.9
ANR307	120.0	$\varnothing 9.0$	STEEL SAE 4140	1.9
ANR308	120.0	$\varnothing 9.0$	SS type 303 or 304	1.9

# NC BLOCK BLANKS 20 mm SERIES ANR320 THRU ANR323

Tolerances:

- 1 PLACE  $\pm 0.3$
- 2 PLACE  $\pm 0.03$
- 3 PLACE  $\pm 0.020$

 SURFACES TO BE FLAT, PARALLEL & PERPENDICULAR TO WITHIN 0.015 T.I.R.

NOTE: Identify with NAAMS CODE number as shown **XXX**.  
Black Oxide Finish  
No Black Oxide Finish to "SS Type" Components

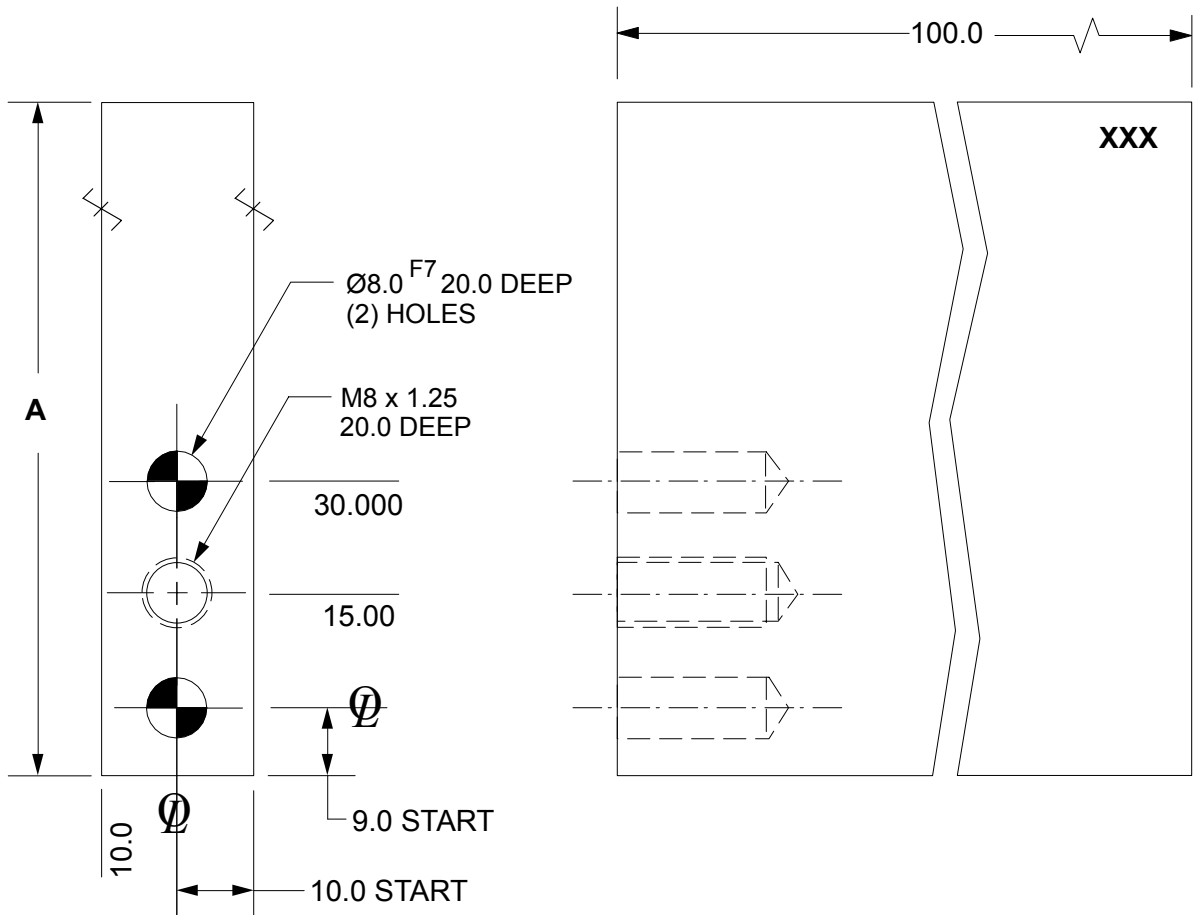

**A**

SEE PAGE B-1.1 FOR GLOBAL MATERIALS CHART

NAAMS CODE	A	MATERIAL	WT. kg
ANR320	80.0	STEEL SAE 4140	1.2
ANR321	80.0	SS type 303 or 304	1.2
ANR322	120.0	STEEL SAE 4140	1.9
ANR323	120.0	SS type 303 or 304	1.9

# NC BLOCK BLANKS 20 mm SERIES ANR311 THRU ANR314

Tolerances:

- 1 PLACE  $\pm 0.3$
- 2 PLACE  $\pm 0.03$
- 3 PLACE  $\pm 0.020$

 SURFACES TO BE FLAT, PARALLEL & PERPENDICULAR TO WITHIN 0.015 T.I.R.

NOTE: Identify with NAAMS CODE number as shown **XXX**.  
Black Oxide Finish  
No Black Oxide Finish to "SS Type" Components

**A**

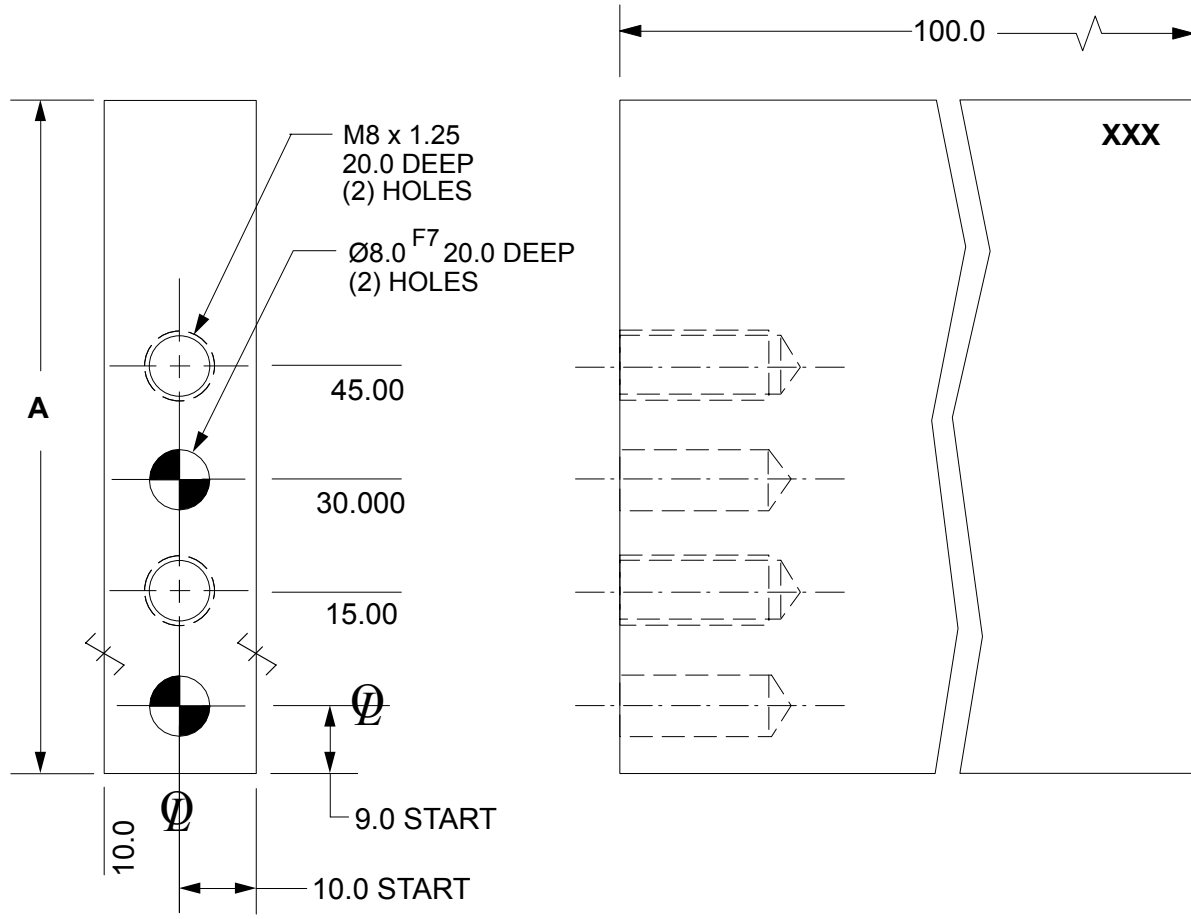

SEE PAGE B-1.1 FOR GLOBAL MATERIALS CHART

NAAMS CODE	A	MATERIAL	WT. kg
ANR311	80.0	STEEL SAE 4140	1.2
ANR312	80.0	SS type 303 or 304	1.2
ANR313	120.0	STEEL SAE 4140	1.9
ANR314	120.0	SS type 303 or 304	1.9