

# L-BLOCKS COMPONENTS INDEX

PAGE	DATE	NAAMS CODE	DESCRIPTION
<a href="#">H-1</a>	02/12/14		L-Blocks Components Index
<a href="#">H-1.1</a>	02/12/14		L-Blocks Components Index
<a href="#">H-2</a>	08/13/07	Discontinued	L-Block (Full Metric) (3 and 4-Hole)
<a href="#">H-3</a>	02/12/14	ALB020M – ALB023M	L-Block (Full Metric) (3 and 4-Hole)
<a href="#">H-4</a>	08/13/07	Discontinued	L-Block (Full Metric) (3-Hole)
<a href="#">H-5</a>	02/12/14	ALB050M – ALB061M	L-Block (Full Metric) (3-Hole)
<a href="#">H-6</a>	02/12/14	ALB070M – ALB081M	L-Block (Full Metric) (4-Hole)
<a href="#">H-7</a>	08/13/07	Discontinued	L-Block (Full Metric) (3-Hole, Wide)
<a href="#">H-8</a>	02/12/14	ALB100M – ALB103M	L-Block (Full Metric) (3-Hole, Wide)
<a href="#">H-9</a>	02/12/14	ALB110M R/L – ALB113M R/L	L-Block (Full Metric) (4-Hole, Wide)
<a href="#">H-10</a>	02/12/14	ALB115M & ALB116M	L-Block (Full Metric) (4-Hole, Wide)
<a href="#">H-11</a>	08/13/07	Discontinued	L-Block (Full Metric) (T-Shaped)
<a href="#">H-12</a>	02/12/14	ALB130M – ALB133M	L-Block (Full Metric) (T-Shaped)
<a href="#">H-13</a>	02/12/14	ALB140M – ALB151M	L-Block (Full Metric) (T-Shaped)
<a href="#">H-14</a>	08/13/07	Discontinued	L-Block (Small) (Full Metric) (3-Hole)
<a href="#">H-15</a>	08/13/07	Discontinued	L-Block (Small) (Full Metric) (4-Hole)
<a href="#">H-16</a>	08/13/07	Discontinued	L-Block (Small) (Full Metric) (3-Hole Wide)
<a href="#">H-17</a>	08/13/07	Discontinued	L-Block (Small) (Full Metric) (4-Hole Wide)
<a href="#">H-18</a>	08/13/07	Discontinued	L-Block (Small) (Full Metric) (T-Shaped)
<a href="#">H-19</a>	08/13/07	Discontinued	L-Block (Small) (Full Metric) (T-Shaped)
<a href="#">H-20</a>	08/13/07	Discontinued	L-Block (3 and 4-Hole, Inch Dimension Holes)
<a href="#">H-21</a>	02/12/14	ALB020 – ALB023	L-Block (3 and 4-Hole, Inch Dimension Holes)
<a href="#">H-22</a>	08/13/07	Discontinued	L-Block (3-Hole, Inch Dimension Holes)
<a href="#">H-23</a>	02/12/14	ALB050 – ALB061	L-Block (3-Hole, Inch Dimension Holes)
<a href="#">H-24</a>	02/12/14	ALB050 – ALB061	L-Block (4-Hole, Inch Dimension Holes)
<a href="#">H-25</a>	08/13/07	Discontinued	L-Block (3-Hole, Wide, Inch Dimension Holes)
<a href="#">H-26</a>	02/12/14	ALB100 – ALB103	L-Block (3-Hole, Wide, Inch Dimension Holes)
<a href="#">H-27</a>	02/12/14	ALB110 – ALB113	L-Block (4-Hole, Wide, Inch Dimension Holes)
<a href="#">H-28</a>	02/12/14	ALB115 – ALB116	L-Block (4-Hole, Wide, Inch Dimension Holes)

# L-BLOCKS COMPONENTS INDEX

PAGE	DATE	NAAMS CODE	DESCRIPTION
<a href="#">H-29</a>	08/13/07	Discontinued	L-Block (T-Shaped, Inch Dimension Holes)
<a href="#">H-30</a>	02/12/14	ALB130 – ALB133	L-Block (T-Shaped, Inch Dimension Holes)
<a href="#">H-31</a>	02/12/14	ALB140 – ALB151	L-Block (T-Shaped, Inch Dimension Holes)
<a href="#">H-32</a>	08/13/07	Discontinued	L-Block (Small) (3-Hole, Inch Dimension Holes)
<a href="#">H-33</a>	08/13/07	Discontinued	L-Block (Small) (4-Hole, Inch Dimension Holes)
<a href="#">H-34</a>	08/13/07	Discontinued	L-Block (Small) (Wide, Inch Dimension Holes)
<a href="#">H-35</a>	08/13/07	Discontinued	L-Block (Small) (Wide, Inch Dimension Holes)
<a href="#">H-36</a>	08/13/07	Discontinued	L-Block (Small) (T-Shaped, Inch Dimension Holes)
<a href="#">H-37</a>	08/13/07	Discontinued	L-Block (Small) (T-Shaped, Inch Dimension Holes)
<a href="#">H-38</a>	02/12/14	ALB320M – ALB323M	L-Block – 20 mm Series (Full Metric)
<a href="#">H-39</a>	03/31/10	Discontinued	L-Block – 20 mm Series (Full Metric)
<a href="#">H-40</a>	02/12/14	ALB370M – ALB381M	L-Block – 20 mm Series (Full Metric)
<a href="#">H-41</a>	09/05/12	Discontinued	L-Block – 20 mm Series (Full Metric)
<a href="#">H-42</a>	02/12/14	ALB410M – ALB413M	L-Block – 20 mm Series (Full Metric)
<a href="#">H-43</a>	02/12/14	ALB415M – ALB416M	L-Block – 20 mm Series (Full Metric)
<a href="#">H-44</a>	02/12/14	ALB430M – ALB433M	L-Block – 20 mm Series (Full Metric)
<a href="#">H-45</a>	02/12/14	ALB330M – ALB341M	L-Block – 20 mm Series (Full Metric)
<a href="#">H-46</a>	02/12/14	ALB510M - ALB513M	L-Block - 20mm Series (Full Metric)
<a href="#">H-47</a>	02/12/14	ALB521M - ALB524M	L-Block - 20mm Series (Full Metric)
<a href="#">H-48</a>	02/12/14	ALB531M - ALB532M	L-Block - 20mm Series (Full Metric)
<a href="#">H-49</a>	02/12/14	ALB551M - ALB554M	L-Block - 20mm Series (Full Metric)
<a href="#">H-50</a>	02/12/14	ALB540M - ALB543M	L-Block - 20mm Series (Full Metric)
<a href="#">H-51</a>	02/12/14	ALB560M - ALB563M	L-Block - 20mm Series (Full Metric)
<a href="#">H-52</a>	02/12/14	ALB570M - ALB573M	L-Block - 20mm Series (Full Metric)
<a href="#">H-53</a>	02/12/14	ALB580M - ALB583M	L-Block - 20mm Series (Full Metric)



# L BLOCK

## ALB070, 071, 080 and 081

GLOBAL STANDARD COMPONENTS



Assembly

02/12/14

Tolerances: METRIC

1 PLACE  $\pm 0.3$

2 PLACE  $\pm 0.03$

3 PLACE  $\pm 0.020$

✓ SURFACES TO BE FLAT, PARALLEL & PERPENDICULAR TO WITHIN 0.015mm T.I.R.

NOTE: Identify with NAAMS CODE number as shown **XXX**.

Black Oxide Finish

No Black Oxide Finish to "SS Type" Components

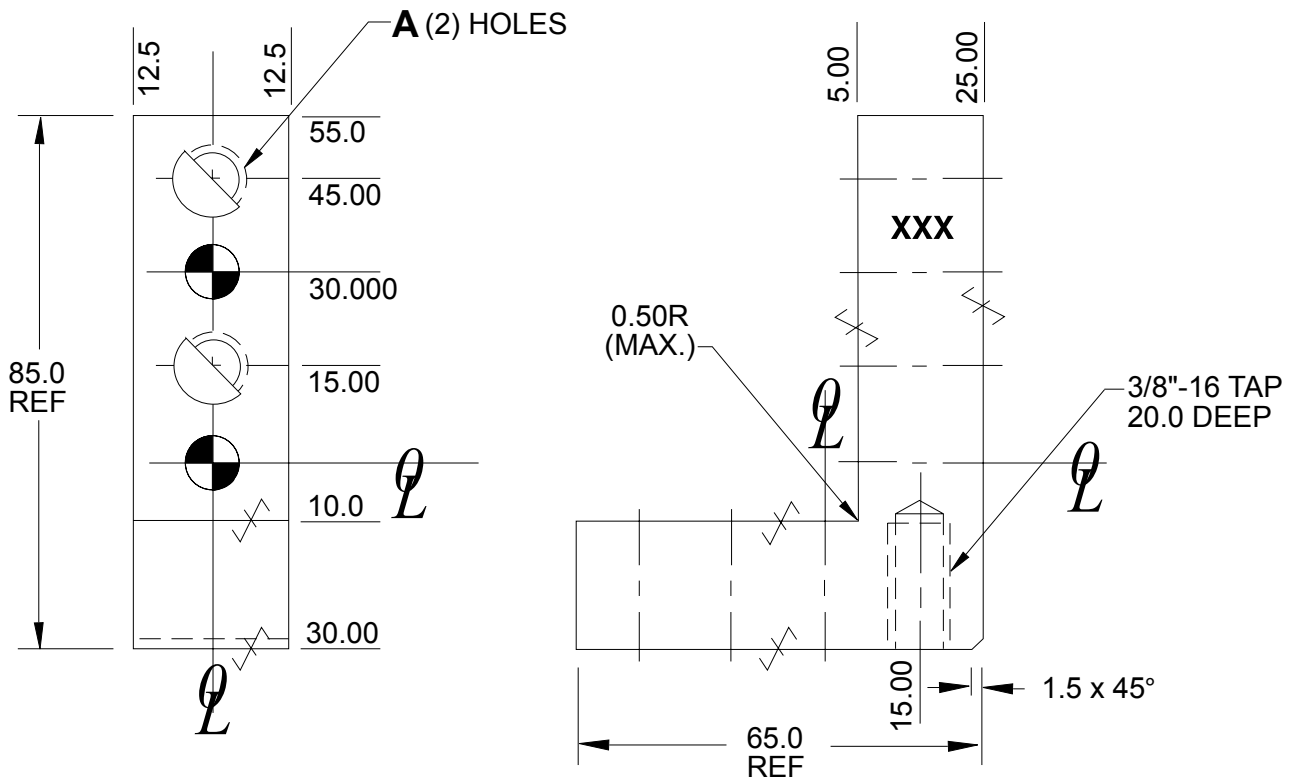
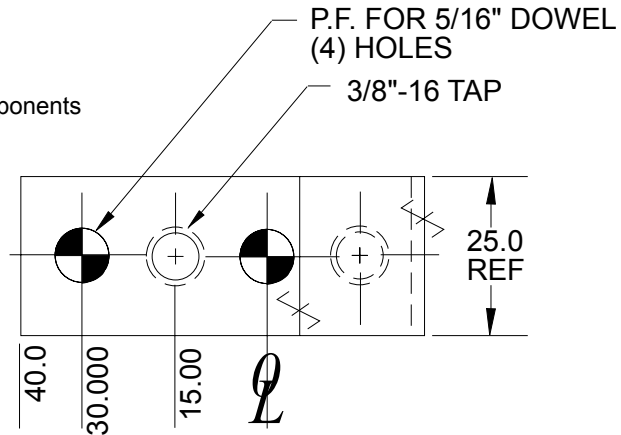

SEE PAGE B-1.1 FOR GLOBAL MATERIALS CHART

NAAMS CODE	A	MATERIAL	WT. kg
ALB070	13/32	STEEL ASTM A-36	0.45
ALB071	13/32	SS type 303 or 304	0.45
ALB080	3/8 -16 tap	STEEL ASTM A-36	0.45
ALB081	3/8 -16 tap	SS type 303 or 304	0.45

A

F

E

B

C

D

# L BLOCK – 20 mm SERIES

## ALB370M, 371M, 380M AND 381M (FULL METRIC)

GLOBAL STANDARD COMPONENTS



Assembly

02/12/14

Tolerances:

- 1 PLACE  $\pm 0.3$
- 2 PLACE  $\pm 0.03$
- 3 PLACE  $\pm 0.020$

This document is Uncontrolled when printed.

✓ SURFACES TO BE FLAT, PARALLEL & PERPENDICULAR TO WITHIN 0.015 T.I.R.

NOTE: Identify with NAAMS CODE number as shown **XXX**.  
Black Oxide Finish  
No Black Oxide Finish to "SS Type" Components

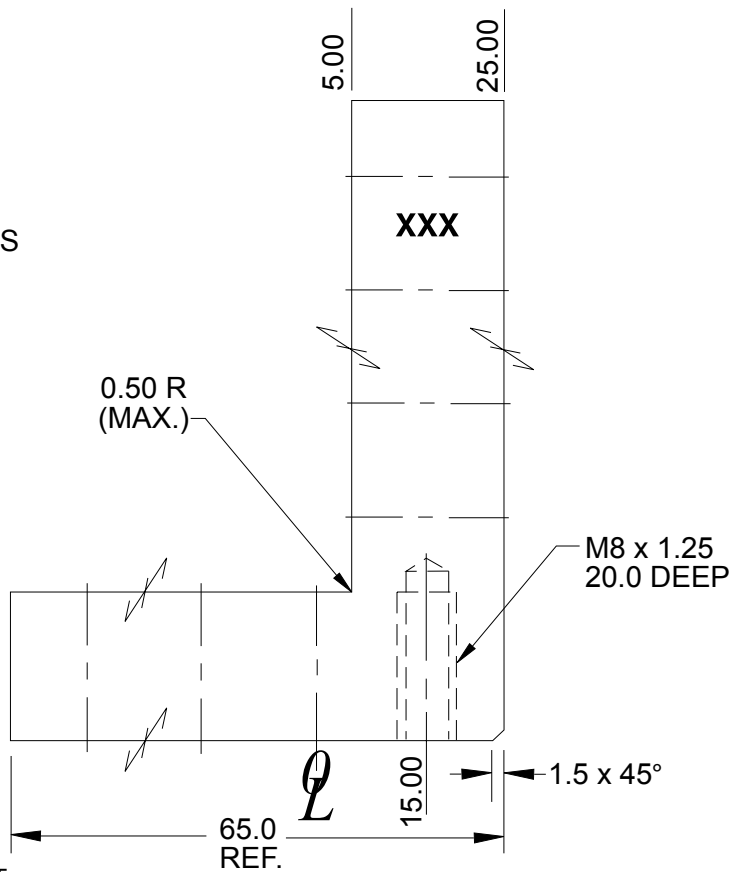
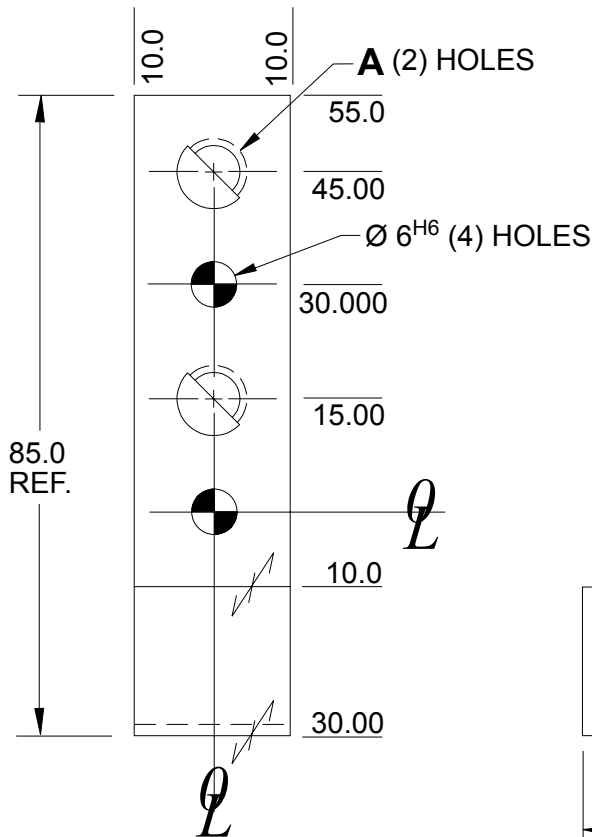
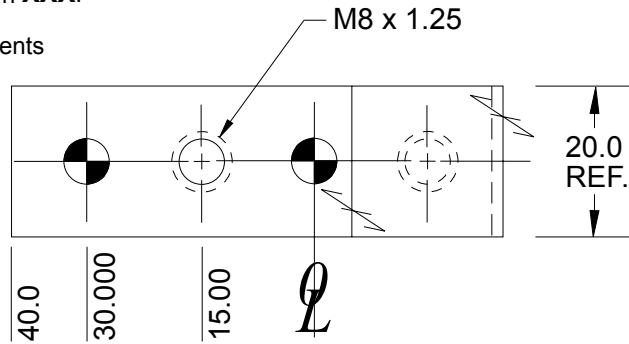

SEE PAGE B-1.1 FOR GLOBAL MATERIALS CHART

NAAMS CODE	A	MATERIAL	WT. kg
ALB380M	M8 x 1.25	STEEL ASTM A-36	0.32
ALB381M	M8 x 1.25	SS type 303 or 304	0.32
ALB370M	Ø 9.0	STEEL ASTM A-36	0.32
ALB371M	Ø 9.0	SS type 303 or 304	0.32

F  
E  
D  
A  
B  
C

# L BLOCK – 20 mm SERIES ALB510M THRU ALB513M (FULL METRIC)

GLOBAL STANDARD COMPONENTS



Assembly

02/12/14

Tolerances:

- 1 PLACE  $\pm 0.3$
- 2 PLACE  $\pm 0.03$
- 3 PLACE  $\pm 0.020$

✓ SURFACES TO BE FLAT, PARALLEL & PERPENDICULAR TO WITHIN 0.015 T.I.R.

NOTE: Identify with NAAMS CODE number as shown **XXX**.  
Black Oxide Finish  
No Black Oxide Finish to "SS Type" Components

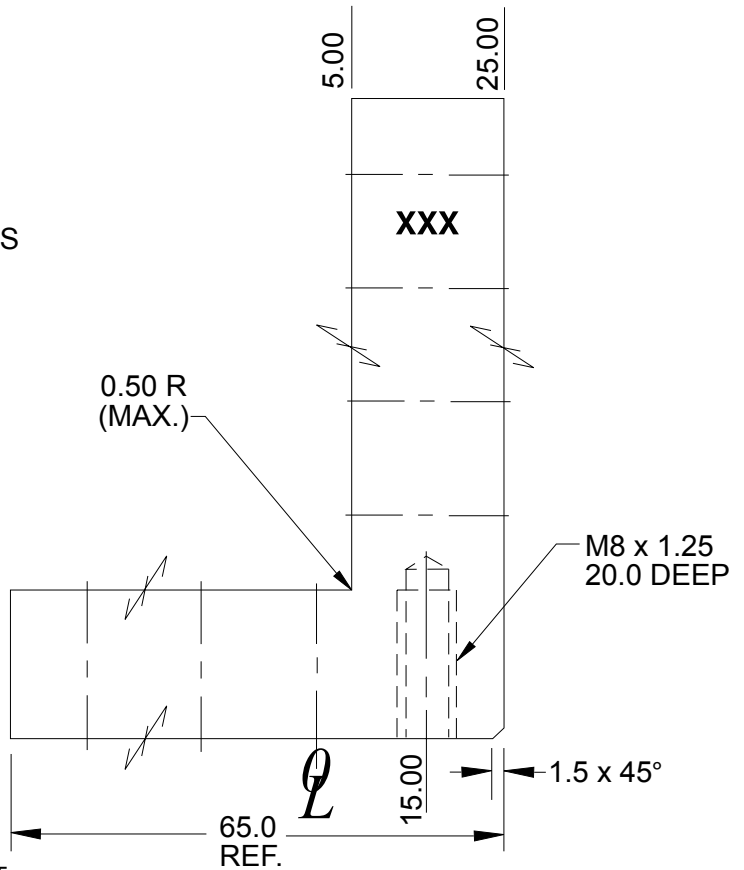
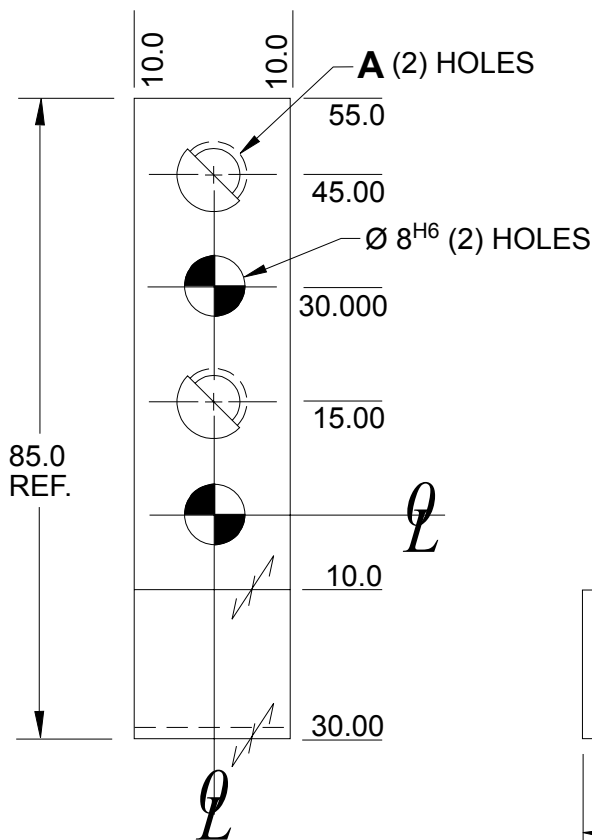
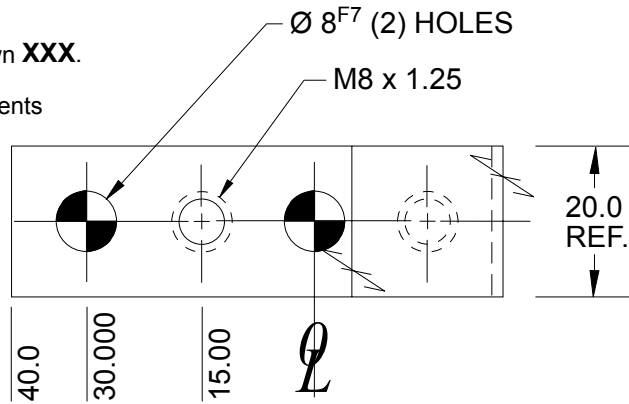

SEE PAGE B-1.1 FOR GLOBAL MATERIALS CHART

NAAMS CODE	A	MATERIAL	WT. kg
ALB510M	M8 x 1.25	STEEL ASTM A-36	0.32
ALB511M	M8 x 1.25	SS type 303 or 304	0.32
ALB512M	$\varnothing 9.0$	STEEL ASTM A-36	0.32
ALB513M	$\varnothing 9.0$	SS type 303 or 304	0.32