

L-BLOCKS COMPONENTS INDEX

PAGE	DATE	NAAMS CODE	DESCRIPTION
H-1	02/12/14		L-Blocks Components Index
H-1.1	02/12/14		L-Blocks Components Index
H-2	08/13/07	Discontinued	L-Block (Full Metric) (3 and 4-Hole)
H-3	02/12/14	ALB020M – ALB023M	L-Block (Full Metric) (3 and 4-Hole)
H-4	08/13/07	Discontinued	L-Block (Full Metric) (3-Hole)
H-5	02/12/14	ALB050M – ALB061M	L-Block (Full Metric) (3-Hole)
H-6	02/12/14	ALB070M – ALB081M	L-Block (Full Metric) (4-Hole)
H-7	08/13/07	Discontinued	L-Block (Full Metric) (3-Hole, Wide)
H-8	02/12/14	ALB100M – ALB103M	L-Block (Full Metric) (3-Hole, Wide)
H-9	02/12/14	ALB110M R/L – ALB113M R/L	L-Block (Full Metric) (4-Hole, Wide)
H-10	02/12/14	ALB115M & ALB116M	L-Block (Full Metric) (4-Hole, Wide)
H-11	08/13/07	Discontinued	L-Block (Full Metric) (T-Shaped)
H-12	02/12/14	ALB130M – ALB133M	L-Block (Full Metric) (T-Shaped)
H-13	02/12/14	ALB140M – ALB151M	L-Block (Full Metric) (T-Shaped)
H-14	08/13/07	Discontinued	L-Block (Small) (Full Metric) (3-Hole)
H-15	08/13/07	Discontinued	L-Block (Small) (Full Metric) (4-Hole)
H-16	08/13/07	Discontinued	L-Block (Small) (Full Metric) (3-Hole Wide)
H-17	08/13/07	Discontinued	L-Block (Small) (Full Metric) (4-Hole Wide)
H-18	08/13/07	Discontinued	L-Block (Small) (Full Metric) (T-Shaped)
H-19	08/13/07	Discontinued	L-Block (Small) (Full Metric) (T-Shaped)
H-20	08/13/07	Discontinued	L-Block (3 and 4-Hole, Inch Dimension Holes)
H-21	02/12/14	ALB020 – ALB023	L-Block (3 and 4-Hole, Inch Dimension Holes)
H-22	08/13/07	Discontinued	L-Block (3-Hole, Inch Dimension Holes)
H-23	02/12/14	ALB050 – ALB061	L-Block (3-Hole, Inch Dimension Holes)
H-24	02/12/14	ALB050 – ALB061	L-Block (4-Hole, Inch Dimension Holes)
H-25	08/13/07	Discontinued	L-Block (3-Hole, Wide, Inch Dimension Holes)
H-26	02/12/14	ALB100 – ALB103	L-Block (3-Hole, Wide, Inch Dimension Holes)
H-27	02/12/14	ALB110 – ALB113	L-Block (4-Hole, Wide, Inch Dimension Holes)
H-28	02/12/14	ALB115 – ALB116	L-Block (4-Hole, Wide, Inch Dimension Holes)

L-BLOCKS COMPONENTS INDEX

PAGE	DATE	NAAMS CODE	DESCRIPTION
H-29	08/13/07	Discontinued	L-Block (T-Shaped, Inch Dimension Holes)
H-30	02/12/14	ALB130 – ALB133	L-Block (T-Shaped, Inch Dimension Holes)
H-31	02/12/14	ALB140 – ALB151	L-Block (T-Shaped, Inch Dimension Holes)
H-32	08/13/07	Discontinued	L-Block (Small) (3-Hole, Inch Dimension Holes)
H-33	08/13/07	Discontinued	L-Block (Small) (4-Hole, Inch Dimension Holes)
H-34	08/13/07	Discontinued	L-Block (Small) (Wide, Inch Dimension Holes)
H-35	08/13/07	Discontinued	L-Block (Small) (Wide, Inch Dimension Holes)
H-36	08/13/07	Discontinued	L-Block (Small) (T-Shaped, Inch Dimension Holes)
H-37	08/13/07	Discontinued	L-Block (Small) (T-Shaped, Inch Dimension Holes)
H-38	02/12/14	ALB320M – ALB323M	L-Block – 20 mm Series (Full Metric)
H-39	03/31/10	Discontinued	L-Block – 20 mm Series (Full Metric)
H-40	02/12/14	ALB370M – ALB381M	L-Block – 20 mm Series (Full Metric)
H-41	09/05/12	Discontinued	L-Block – 20 mm Series (Full Metric)
H-42	02/12/14	ALB410M – ALB413M	L-Block – 20 mm Series (Full Metric)
H-43	02/12/14	ALB415M – ALB416M	L-Block – 20 mm Series (Full Metric)
H-44	02/12/14	ALB430M – ALB433M	L-Block – 20 mm Series (Full Metric)
H-45	02/12/14	ALB330M – ALB341M	L-Block – 20 mm Series (Full Metric)
H-46	02/12/14	ALB510M - ALB513M	L-Block - 20mm Series (Full Metric)
H-47	02/12/14	ALB521M - ALB524M	L-Block - 20mm Series (Full Metric)
H-48	02/12/14	ALB531M - ALB532M	L-Block - 20mm Series (Full Metric)
H-49	02/12/14	ALB551M - ALB554M	L-Block - 20mm Series (Full Metric)
H-50	02/12/14	ALB540M - ALB543M	L-Block - 20mm Series (Full Metric)
H-51	02/12/14	ALB560M - ALB563M	L-Block - 20mm Series (Full Metric)
H-52	02/12/14	ALB570M - ALB573M	L-Block - 20mm Series (Full Metric)
H-53	02/12/14	ALB580M - ALB583M	L-Block - 20mm Series (Full Metric)

L BLOCK (FULL METRIC) ALB040M, 041M, 042M AND 043M

B

Tolerances: 1 PLACE ± 0.3
2 PLACE ± 0.03
3 PLACE ± 0.020

✓ SURFACES TO BE FLAT, PARALLEL & PERPENDICULAR TO WITHIN 0.015 T.I.R.

NOTE: Identify with NAAMS CODE number as shown **XXX**.
Black Oxide Finish

A

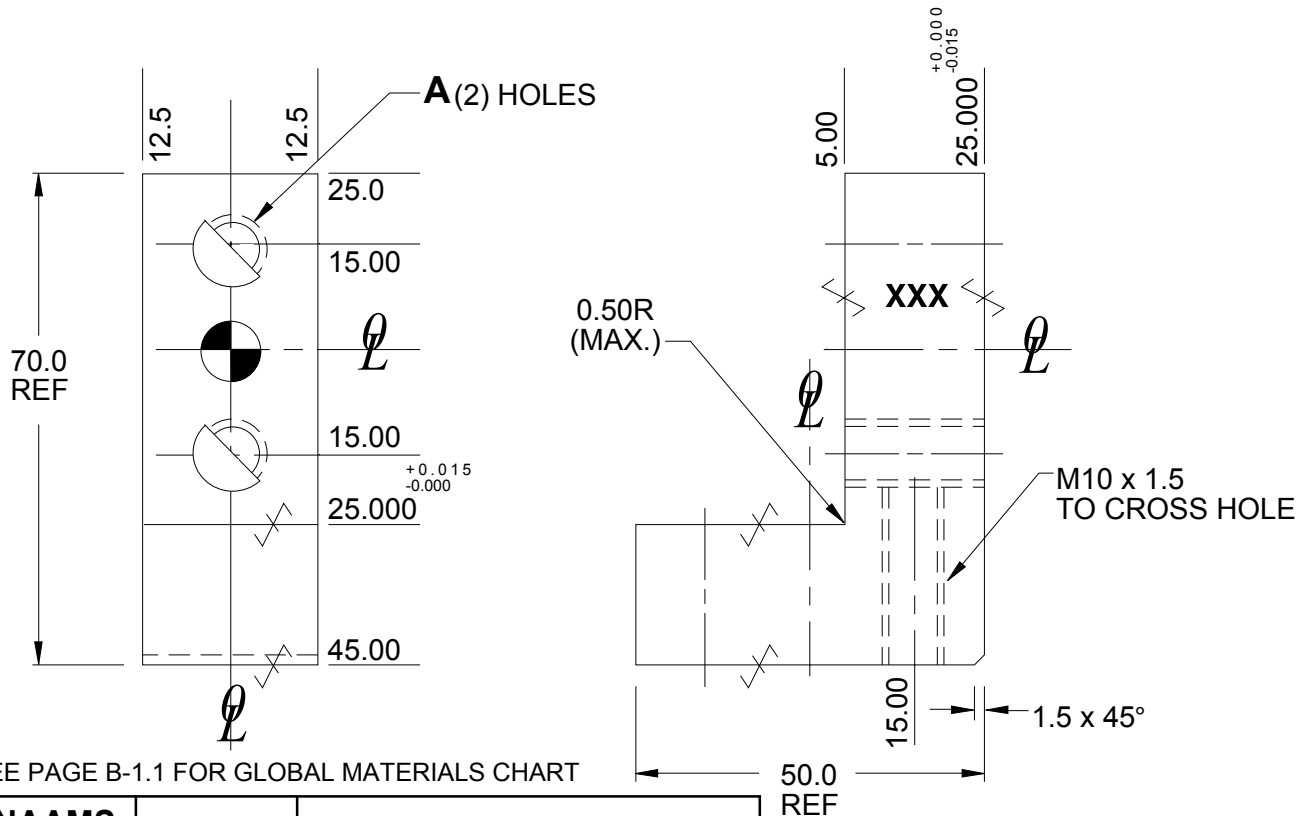
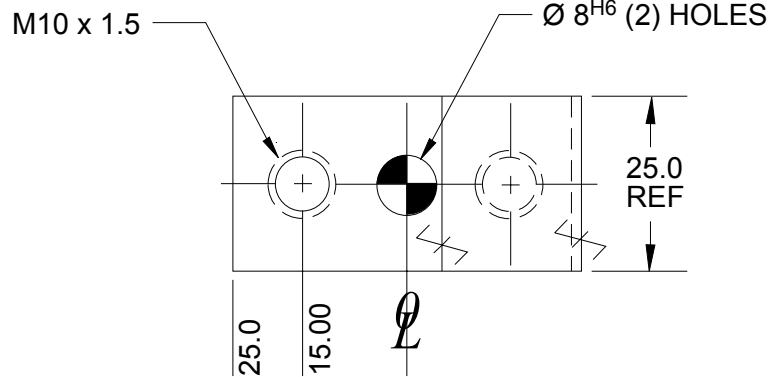

SEE PAGE B-1.1 FOR GLOBAL MATERIALS CHART

NAAMS CODE	A	MATERIAL
ALB040M	M10 x 1.5	STEEL ASTM A-36
ALB041M	M10 x 1.5	NM Stainless
ALB042M	11.0	STEEL ASTM A-36
ALB043M	11.0	NM Stainless

D

C

L BLOCK (FULL METRIC) ALB050M, 051M, 060M AND 061M

GLOBAL STANDARD COMPONENTS



Assembly

02/12/14

Tolerances: 1 PLACE ± 0.3
2 PLACE ± 0.03
3 PLACE ± 0.020

✓ SURFACES TO BE FLAT, PARALLEL & PERPENDICULAR TO WITHIN 0.015 T.I.R.

NOTE: Identify with NAAMS CODE number as shown **XXX**.

Black Oxide Finish

No Black Oxide Finish to "SS Type" Components

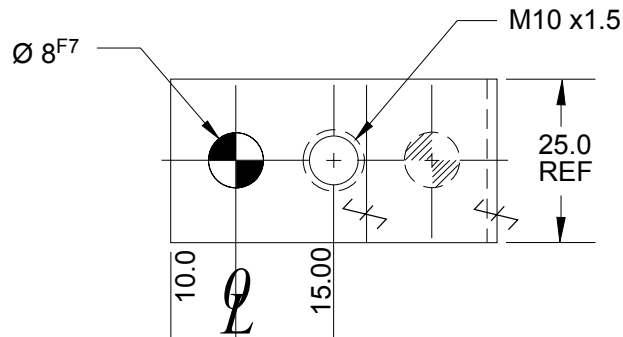

A
D
G

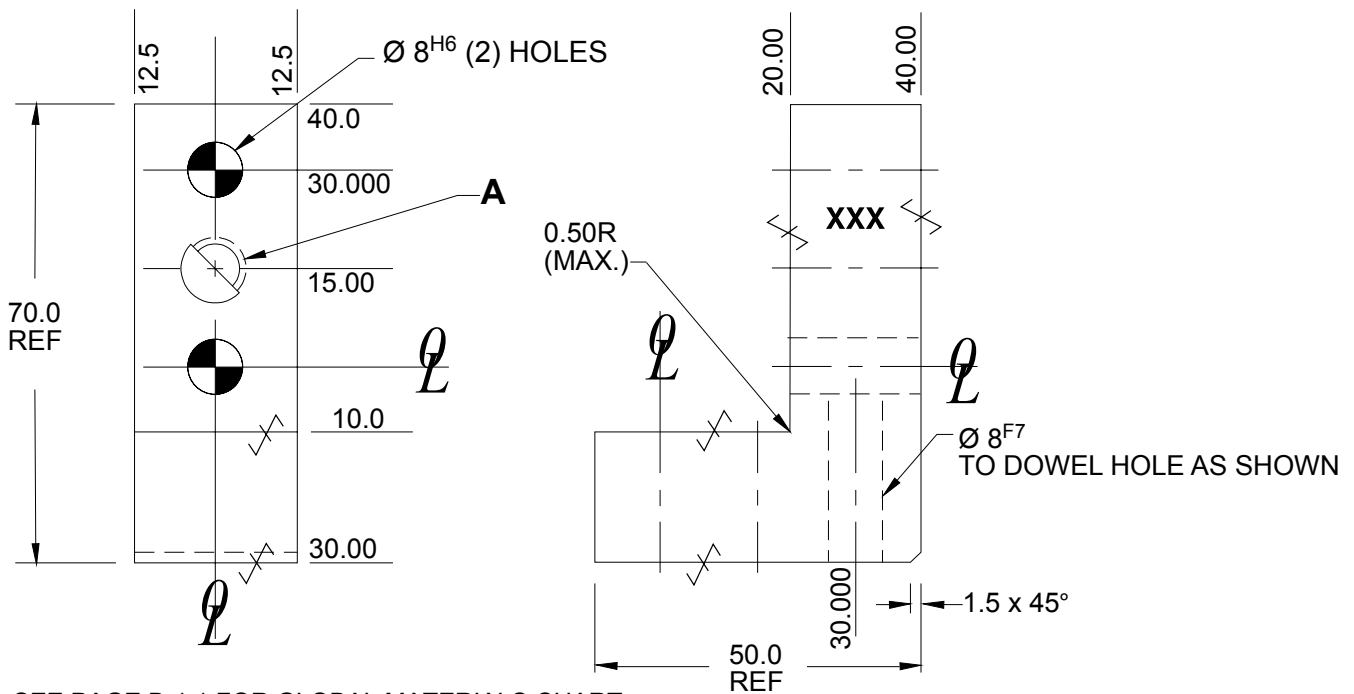

D

D

SEE PAGE B-1.1 FOR GLOBAL MATERIALS CHART

NAAMS CODE	A	MATERIAL	WT. kg
ALB050M	M10 x 1.5	STEEL ASTM A-36	0.32
ALB051M	M10 x 1.5	SS type 303 or 304	0.32
ALB060M	11.0	STEEL ASTM A-36	0.32
ALB061M	11.0	SS type 303 or 304	0.32

F
B
C
E

L BLOCK

ALB040, 041, 042 and 043

GLOBAL STANDARD COMPONENTS



Assembly

08/13/07

B

Tolerances: METRIC

1 PLACE ± 0.3

2 PLACE ± 0.03

3 PLACE ± 0.020

SURFACES TO BE FLAT, PARALLEL & PERPENDICULAR TO WITHIN 0.015mm T.I.R.

NOTE: Identify with NAAMS CODE number as shown **XXX**.

Black Oxide Finish 3/8" - 16 TAP

P.F. FOR 5/16" DOWEL (2) HOLES

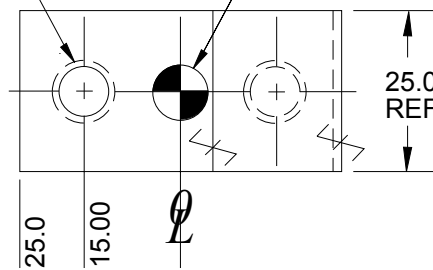

A

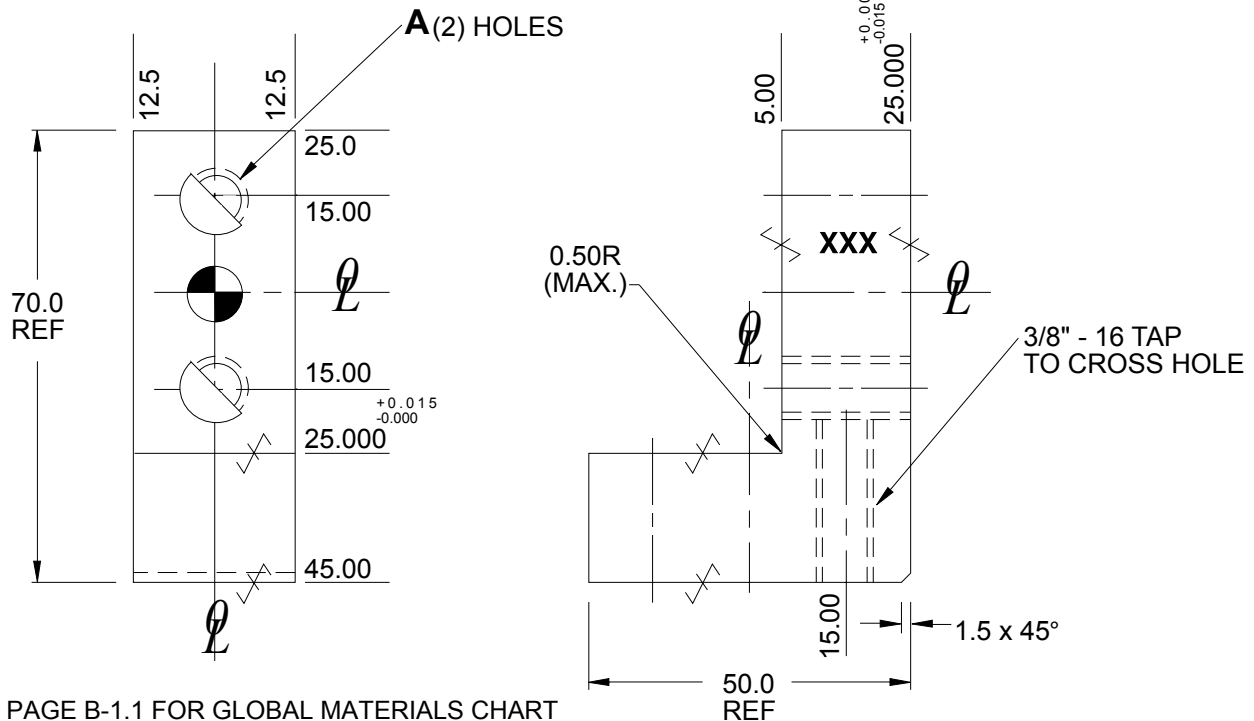

SEE PAGE B-1.1 FOR GLOBAL MATERIALS CHART

NAAMS CODE	A	MATERIAL
ALB040	3/8 -16 tap	STEEL ASTM A-36
ALB041	3/8 -16 tap	NM Stainless
ALB042	13/32	STEEL ASTM A-36
ALB043	13/32	NM Stainless

D
C

L BLOCK

ALB050, 051, 060 and 061

GLOBAL STANDARD COMPONENTS



Assembly

02/12/14

Tolerances: METRIC

1 PLACE ± 0.3

2 PLACE ± 0.03

3 PLACE ± 0.020

✓ SURFACES TO BE FLAT, PARALLEL & PERPENDICULAR TO WITHIN 0.015mm T.I.R.

NOTE: Identify with NAAMS CODE number as shown **XXX**.

Black Oxide Finish

No Black Oxide Finish to "SS Type" Components

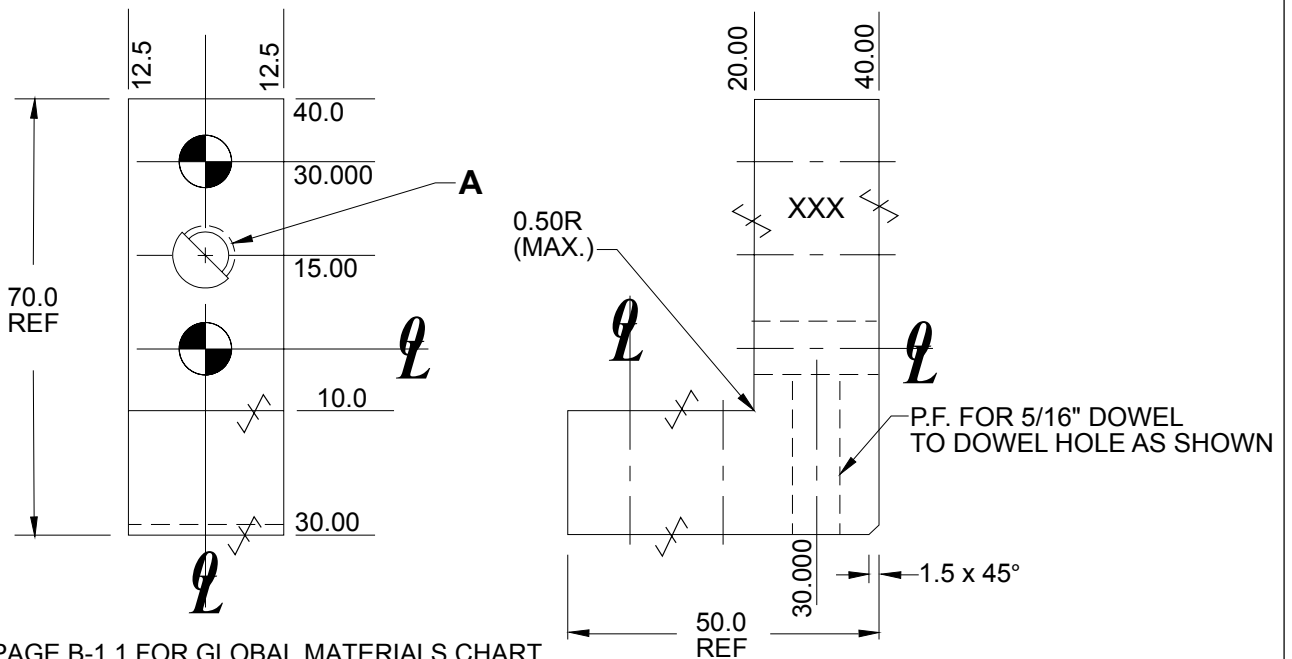
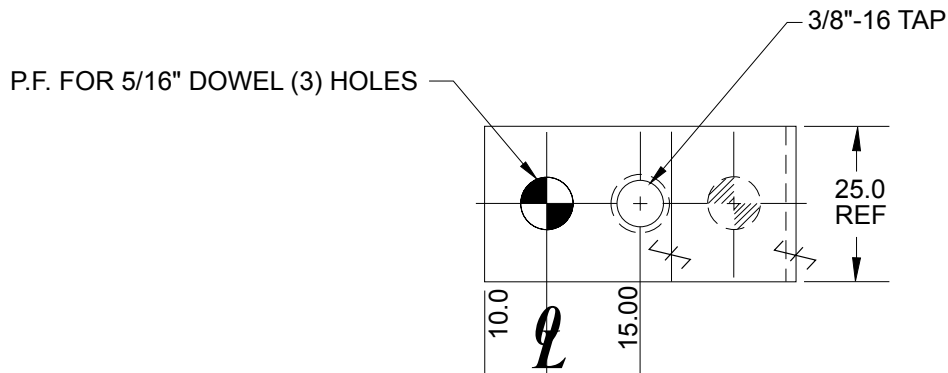

SEE PAGE B-1.1 FOR GLOBAL MATERIALS CHART

NAAMS CODE	A	MATERIAL	WT. kg
ALB050	3/8 -16 tap	STEEL ASTM A-36	0.32
ALB051	3/8 -16 tap	SS type 303 or 304	0.32
ALB060	13/32	STEEL ASTM A-36	0.32
ALB061	13/32	SS type 303 or 304	0.32

A
F

E
B
C
D

