

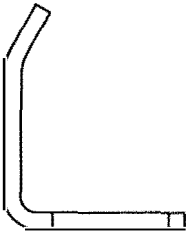
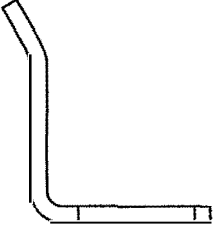

ROUGH LOCATORS (1018)

INDEX

<u>PART NUMBER</u>	<u>DESCRIPTION</u>	<u>MATERIAL</u>		<u>PAGE</u>
ARL 075R	ROUGH LOCATORS NAAMS (RIGHT)	STEEL(C1018)		1
ARL 100R		STEEL(C1018)		
ARL 125R		STEEL(C1018)		
ARL 150R		STEEL(C1018)		
ARL 175R		STEEL(C1018)		
ARL 200R		STEEL(C1018)		
ARL 225R		STEEL(C1018)		
ARL 320R		STEEL(C1018)		
ARL 075L	ROUGH LOCATORS NAAMS (LEFT)	STEEL(C1018)		2
ARL 100L		STEEL(C1018)		
ARL 125L		STEEL(C1018)		
ARL 150L		STEEL(C1018)		
ARL 175L		STEEL(C1018)		
ARL 200L		STEEL(C1018)		
ARL 225L		STEEL(C1018)		
ARL 320L		STEEL(C1018)		
ARL 145	ROUGH LOCATORS NAAMS (STRAIGHT)	STEEL(C1018)		3
ARL 170		STEEL(C1018)		
ARL 195		STEEL(C1018)		
ARL 220		STEEL(C1018)		
ARL 245		STEEL(C1018)		
ARL 270		STEEL(C1018)		
ARL 298		STEEL(C1018)		
ARL 320		STEEL(C1018)		
U ARLA 075R	ROUGH LOCATORS W/DOUBLE SLOTS (RIGHT)	STEEL(C1018)		4
U ARLA 100R		STEEL(C1018)		
U ARLA 125R		STEEL(C1018)		
U ARLA 150R		STEEL(C1018)		
U ARLA 175R		STEEL(C1018)		
U ARLA 200R		STEEL(C1018)		
U ARLA 225R		STEEL(C1018)		
U ARLA 320R		STEEL(C1018)		
U AWL 075R	ROUGH LOCATORS W/UHMW WEARPLATE (RIGHT)	STEEL(C1018)		5
U AWL 100R		STEEL(C1018)		
U AWL 125R		STEEL(C1018)		
U AWL 150R		STEEL(C1018)		
U AWL 175R		STEEL(C1018)		
U AWL 200R		STEEL(C1018)		
U AWL 225R		STEEL(C1018)		
U AWL 320R		STEEL(C1018)		

CAD FILE	
DRAWING REV.	N/A
PAGE REV.	9/1/00
REVISION	1

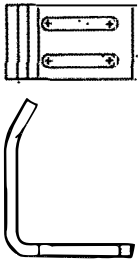
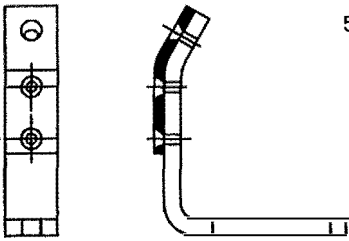
Freer Tool and Supply  
 44675 Morley Dr, Clinton Township, MI 48036  
 586-463-3200  
 Sales@Freertool.com

SECTION  
**G**

ROUGH LOCATORS (1018)

INDEX

PART NUMBER

DESCRIPTION

MATERIAL

PAGE

U AWLA 075 R ROUGH LOCATORS STEEL(C1018)  
 U AWLA 100 R W/DOUBLE SLOT STEEL(C1018)  
 U AWLA 125 R AND UHMW STEEL(C1018)  
 U AWLA 150 R WEARPLATE STEEL(C1018)  
 U AWLA 175 R (RIGHT) STEEL(C1018)  
 U AWLA 200 R STEEL(C1018)  
 U AWLA 225 R STEEL(C1018)  
 U AWLA 250 R STEEL(C1018)

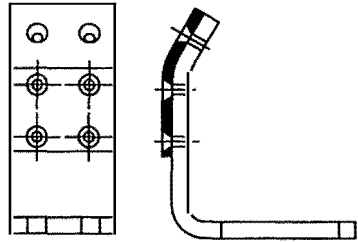

6

U AGL 175 R ROUGH LOCATORS STEEL(C1018)  
 U AGL 200 R W/GUSSET STEEL(C1018)  
 U AGL 225 R (RIGHT) STEEL(C1018)  
 U AGL 250 R STEEL(C1018)

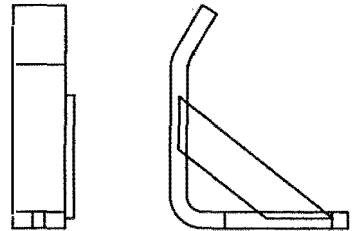

7

U AGLA 175 R ROUGH LOCATORS STEEL(C1018)  
 U AGLA 200 R W/DOUBLE SLOT STEEL(C1018)  
 U AGLA 225 R AND GUSSET STEEL(C1018)  
 U AGLA 250 R (RIGHT) STEEL(C1018)

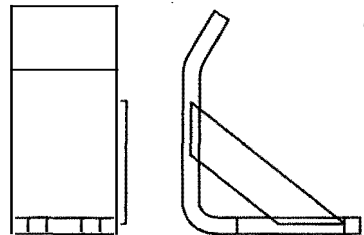

8

U AGW 175 R ROUGH LOCATORS STEEL(C1018)  
 U AGW 200 R W/GUSSET AND STEEL(C1018)  
 U AGW 225 R UHMW WEARPLATE STEEL(C1018)  
 U AGW 250 R (RIGHT) STEEL(C1018)

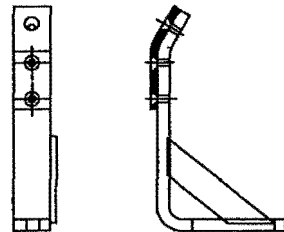

9

U AGWA 175 R ROUGH LOCATORS STEEL(C1018)  
 U AGWA 200 R W/DOUBLE SLOT STEEL(C1018)  
 U AGWA 225 R UHMW WEARPLATE STEEL(C1018)  
 U AGWA 250 R AND GUSSET STEEL(C1018)  
 (RIGHT)

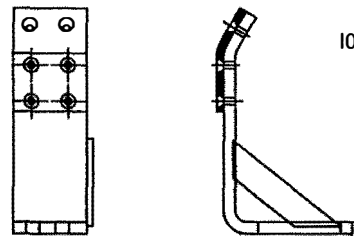

10

CAD FILE	
DRAWING REV.	N/A
PAGE REV.	9/1/00
REVISION	I

Freer Tool and Supply  
 44675 Morley Dr, Clinton Township, MI 48036  
 586-463-3200  
 Sales@Freertool.com

SECTION  
**G**

ROUGH LOCATORS (1018)

INDEX

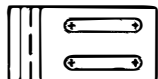
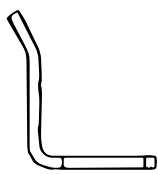
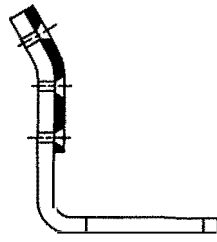
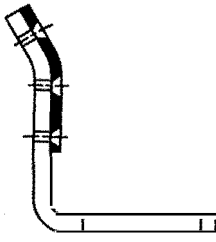
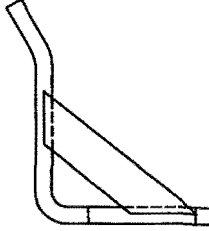
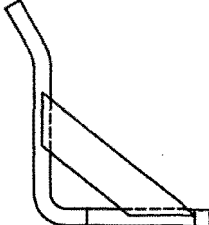
PART NUMBER	DESCRIPTION	MATERIAL		PAGE
U ARLA 075 L	ROUGH LOCATORS	STEEL(C1018)		11
U ARLA 100 L	W/DOUBLE SLOT	STEEL(C1018)		
U ARLA 125 L	(LEFT)	STEEL(C1018)		
U ARLA 150 L	STEEL(C1018)	STEEL(C1018)		
U ARLA 175 L	STEEL(C1018)	STEEL(C1018)		
U ARLA 200 L	STEEL(C1018)	STEEL(C1018)		
U ARLA 250 L	STEEL(C1018)	STEEL(C1018)		
U ARLA 250 L	STEEL(C1018)	STEEL(C1018)		
U AWL 075 L	ROUGH LOCATORS	STEEL(C1018)		12
U AWL 100 L	W/UHWM WEARPLATE	STEEL(C1018)		
U AWL 125 L	(LEFT)	STEEL(C1018)		
U AWL 150 L	STEEL(C1018)	STEEL(C1018)		
U AWL 175 L	STEEL(C1018)	STEEL(C1018)		
U AWL 200 L	STEEL(C1018)	STEEL(C1018)		
U AWL 225 L	STEEL(C1018)	STEEL(C1018)		
U AWL 250 L	STEEL(C1018)	STEEL(C1018)		
U AWLA 075 L	ROUGH LOCATORS	STEEL(C1018)		13
U AWLA 100 L	W/DOUBLE SLOT	STEEL(C1018)		
U AWLA 125 L	AND UHWM	STEEL(C1018)		
U AWLA 150 L	WEARPLATE	STEEL(C1018)		
U AWLA 175 L	(LEFT)	STEEL(C1018)		
U AWLA 200 L	STEEL(C1018)	STEEL(C1018)		
U AWLA 225 L	STEEL(C1018)	STEEL(C1018)		
U AWLA 250 L	STEEL(C1018)	STEEL(C1018)		
U AGL 175 L	ROUGH LOCATORS	STEEL(C1018)		14
U AGL 200 L	W/GUSSET	STEEL(C1018)		
U AGL 225 L	(LEFT)	STEEL(C1018)		
U AGL 250 L	STEEL(C1018)	STEEL(C1018)		
U AGLA 175 L	ROUGH LOCATORS	STEEL(C1018)		15
U AGLA 200 L	W/DOUBLE SLOT	STEEL(C1018)		
U AGLA 225 L	AND GUSSET	STEEL(C1018)		
U AGLA 250 L	(LEFT)	STEEL(C1018)		

CAD FILE	
DRAWING REV.	N/A
PAGE REV.	9/1/00
REVISION	I

Freer Tool and Supply  
 44675 Morley Dr, Clinton Township, MI 48036  
 586-463-3200  
 Sales@FreerTool.com

SECTION  
**G**

ROUGH LOCATORS (1018)

INDEX

PART NUMBER

DESCRIPTION

MATERIAL

PAGE

U AGW 175 L  
 U AGW 200 L  
 U AGW 225 L  
 U AGW 250 L

ROUGH LOCATORS  
 W/GUSSET AND  
 UHMW WEARPLATE  
 (LEFT)

STEEL(C1018)  
 STEEL(C1018)  
 STEEL(C1018)  
 STEEL(C1018)

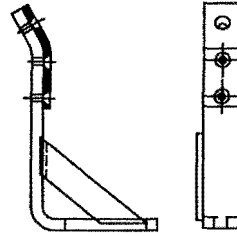

16

U AGWA 175 L  
 U AGWA 200 L  
 U AGWA 225 L  
 U AGWA 250 L

ROUGH LOCATORS  
 W/DOUBLE SLOT,  
 GUSSET AND UHMW  
 WEARPLATE  
 (LEFT)

STEEL(C1018)  
 STEEL(C1018)  
 STEEL(C1018)  
 STEEL(C1018)

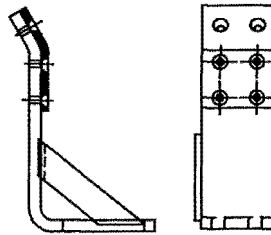

17

U ARLB 145  
 U ARLB 170  
 U ARLB 195  
 U ARLB 220  
 U ARLB 245  
 U ARLB 270  
 U ARLB 298  
 U ARLB 320

ROUGH LOCATORS  
 W/DOUBLE HOLE  
 (STRAIGHT)

STEEL(C1018)  
 STEEL(C1018)  
 STEEL(C1018)  
 STEEL(C1018)  
 STEEL(C1018)  
 STEEL(C1018)  
 STEEL(C1018)  
 STEEL(C1018)

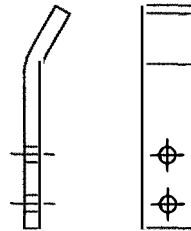

18

U ARLC 075R  
 U ARLC 100R  
 U ARLC 125R  
 U ARLC 150R  
 U ARLC 175R  
 U ARLC 200R  
 U ARLC 225R  
 U ARLC 250R

ROUGH LOCATORS  
 SHORT BASE  
 (RIGHT)

STEEL(C1018)  
 STEEL(C1018)  
 STEEL(C1018)  
 STEEL(C1018)  
 STEEL(C1018)  
 STEEL(C1018)  
 STEEL(C1018)

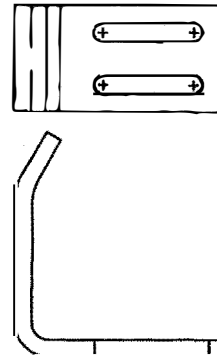

19

CAD FILE	
DRAWING REV.	N/A
PAGE REV.	9/1/00
REVISION	I

Freer Tool and Supply  
 44675 Morley Dr, Clinton Township, MI 48036  
 586-463-3200  
 Sales@Freertool.com

SECTION  
**G**

<u>PART NUMBER</u>	<u>DESCRIPTION</u>	<u>MATERIAL</u>
U-ARLC 075L	ROUGH LOCATORS SHORT BASE (LEFT)	1018 CARBON STEEL
U-ARLC 100L		
U-ARLC 125L		
U-ARLC 150L		
U-ARLC 175L		
U-ARLC 200L		
U-ARLC 225L		
U-ARLC 250L		

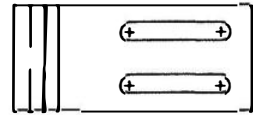

20

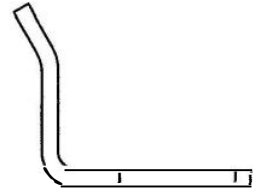

CAD FILE	
DRAWING REV.	N/A
PAGE REV.	9/1/00
REVISION	I

Freer Tool and Supply  
 44675 Morley Dr, Clinton Township, MI 48036  
 586-463-3200  
 Sales@FreerTool.com

SECTION  
**G**

# ROUGH LOCATORS (1018) ARL075R ~ ARL250R

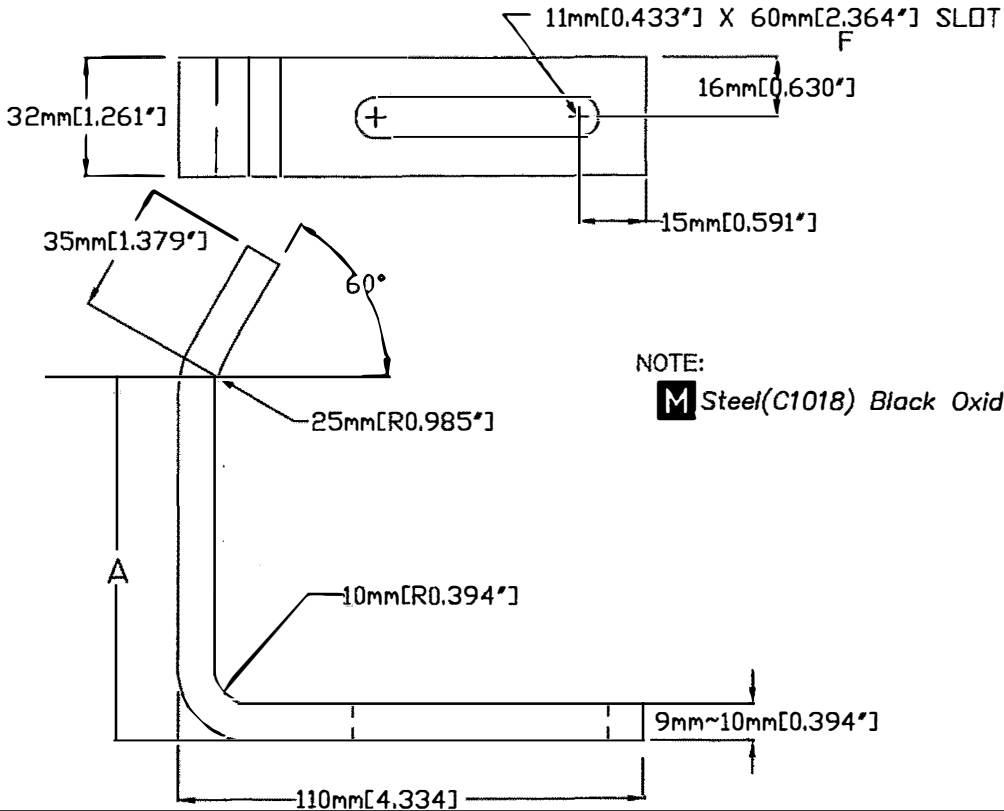

NOTE:

**M** Steel(C1018) Black Oxide Finish

## SPECIFICATIONS & PRICING:

CATALOG		FINISH		A	UNIT PRICE			
TYPE	No.	CODE	DESCRIPTION	METRIC (INCH)	BLACK OXIDE FINISH			
					QTY: 1-19	QTY: 20-49	QTY: 50-99	QTY: 100 +
ARL	075R	CB	BLACK OXIDE	75MM [2.953"]				
	100R			100MM [3.937"]				
	125R			125MM [4.921"]				
	150R			150MM [5.906"]				
	175R			175MM [6.890"]				
	200R			200MM [7.874"]				
	225R			225MM [8.858"]				
	250R			250MM [9.843"]				

### HOW TO ORDER:

CATALOG TYPE & NO. & FINISH

ARL 075R -CB

### HOW TO ORDER: ALTERATIONS

CATALOG TYPE & NO. & FINISH - ALTERATION

ARL 075R -SR -FC70

ALTERATIONS	CODE	SPECIFICATIONS	\$ / CODE
	FC	FC70 = 70MM SLOT SLOT DISTANCE TO LOCATOR END WILL BE 10MM	N/C
SAFETY RED COLOR PAINT	SR	REPLACE BLACK OXIDE FINISH WITH SAFETY RED PAINT	

NOTE:  
CHECK AVAILABILITY WHEN ORDERING  
QUANTITIES OVER 99 PIECES.

FREER TOOL AND SUPPLY, 44675 MORLEY DR, CLINTON TOWNSHIP, MI 48036, 586-463-3200

CAD FILE		PAGE
DRAWING REV. 11/13/96		G-01
PAGE REV. 9/1/00		
REVISION 1		

# ROUGH LOCATORS (1018) ARL075L ~ ARL250L

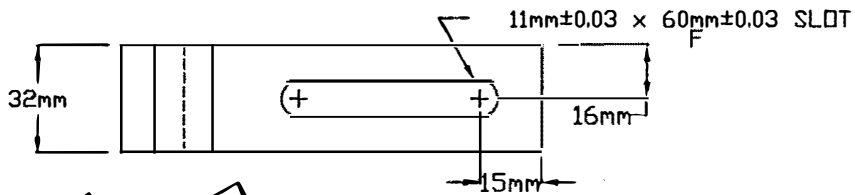

NOTE:

**M** Steel(C1018) Black Oxide Finish

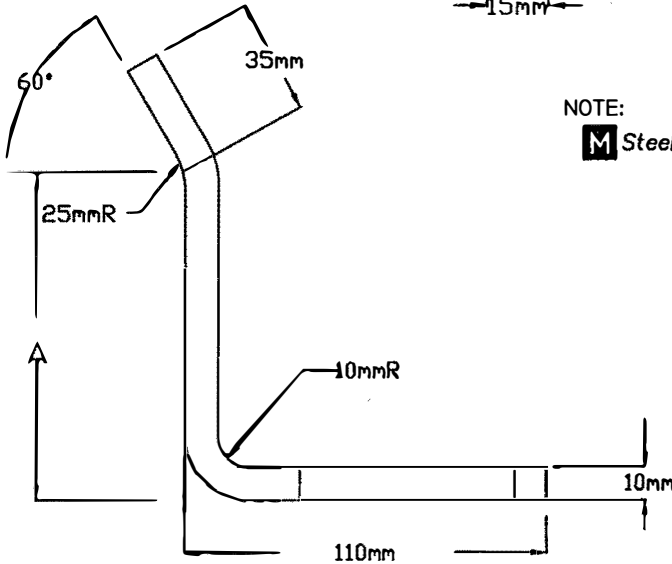

**SPECIFICATIONS & PRICING:**

CATALOG		FINISH		A	UNIT PRICE			
TYPE	No.	CODE	DESCRIPTION	METRIC (INCH)	BLACK OXIDE FINISH			
					QTY: 1-19	QTY: 20-49	QTY: 50-99	QTY: 100 +
ARL	075L	CB	BLACK OXIDE	75MM [2.953"]				
	100L			100MM [3.937"]				
	125L			125MM [4.921"]				
	150L			150MM [5.906"]				
	175L			175MM [6.890"]				
	200L			200MM [7.874"]				
	225L			225MM [8.858"]				
	250L			250MM [9.843"]				

**HOW TO ORDER:**

CATALOG TYPE & NO. & FINISH

ARL 075L -CB

**HOW TO ORDER: ALTERATIONS**

CATALOG TYPE & NO. & FINISH - ALTERATION

ARL 075L -SR -FC70

ALTERATIONS	CODE	SPECIFICATIONS	\$ / CODE
	FC	FC70 = 70MM SLOT SLOT DISTANCE TO LOCATOR END WILL BE 10MM	N/C
SAFETY RED COLOR PAINT	SR	REPLACE BLACK OXIDE FINISH WITH SAFETY RED PAINT	

NOTE:  
CHECK AVAILABILITY WHEN ORDERING  
QUANTITIES OVER 99 PIECES.

FREER TOOL AND SUPPLY, 44675 MORLEY DR, CLINTON TOWNSHIP, MI 48036, 586-463-3200

ICAD FILE	
DRAWING REV. 11/13/96	
PAGE REV. 9/1/00	
REVISION 1	

PAGE	
G-02	

# ROUGH LOCATORS (1018) ARL145 ~ ARL320

NOTE:

**M** Steel(C1018) Black Oxide Finish

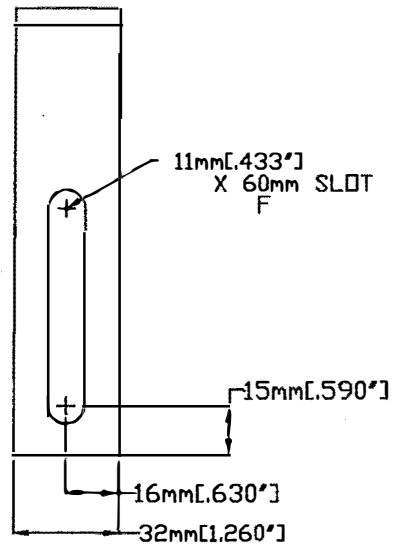
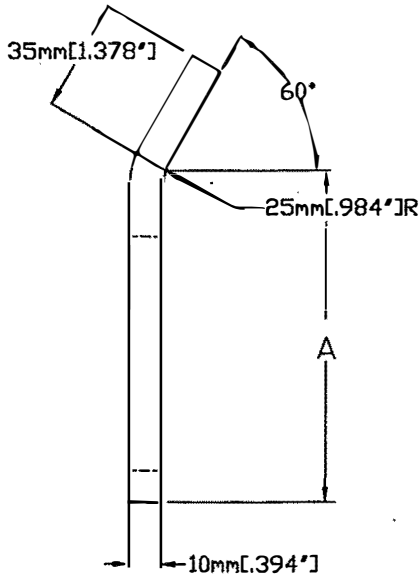

**SPECIFICATIONS & PRICING:**

CATALOG		FINISH		A	UNIT PRICE			
TYPE	No.	CODE	DESCRIPTION	METRIC (INCH)	BLACK OXIDE FINISH			
					QTY: 1-19	QTY: 20-49	QTY: 50-99	QTY: 100 +
ARL	145	CB	BLACK OXIDE	145MM [5.709"]				
	170			170MM [6.693"]				
	195			195MM [7.677"]				
	220			220MM [8.661"]				
	245			245MM [9.646"]				
	270			270MM [10.630"]				
	298			295MM [11.614"]				
	320			320MM [12.598"]				

**HOW TO ORDER:**

CATALOG TYPE & NO. & FINISH

ARL 145 -CB

**HOW TO ORDER: ALTERATIONS**

CATALOG TYPE & NO. & FINISH - ALTERATION

ARL 145 -SR -FC70

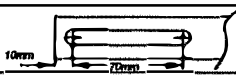
ALTERATIONS	CODE	SPECIFICATIONS	\$ / CODE
	FC	FC70 = 70MM SLOT SLOT DISTANCE TO LOCATOR END WILL BE 10MM	N/C
SAFETY RED COLOR PAINT	SR	REPLACE BLACK OXIDE FINISH WITH SAFETY RED PAINT	

NOTE:  
CHECK AVAILABILITY WHEN ORDERING  
QUANTITIES OVER 99 PIECES.

FREER TOOL AND SUPPLY, 44675 MORLEY DR, CLINTON TOWNSHIP, MI 48036, 586-463-3200

CAD FILE	
DRAWING REV. 11/13/96	
PAGE REV. 9/1/00	
REVISION 1	

PAGE

G-03



# ROUGH LOCATORS (1018) U-ARLA075R ~ U-ARLA250R

NOTE:

**M** Steel (C1018)  
Black Oxide Finish

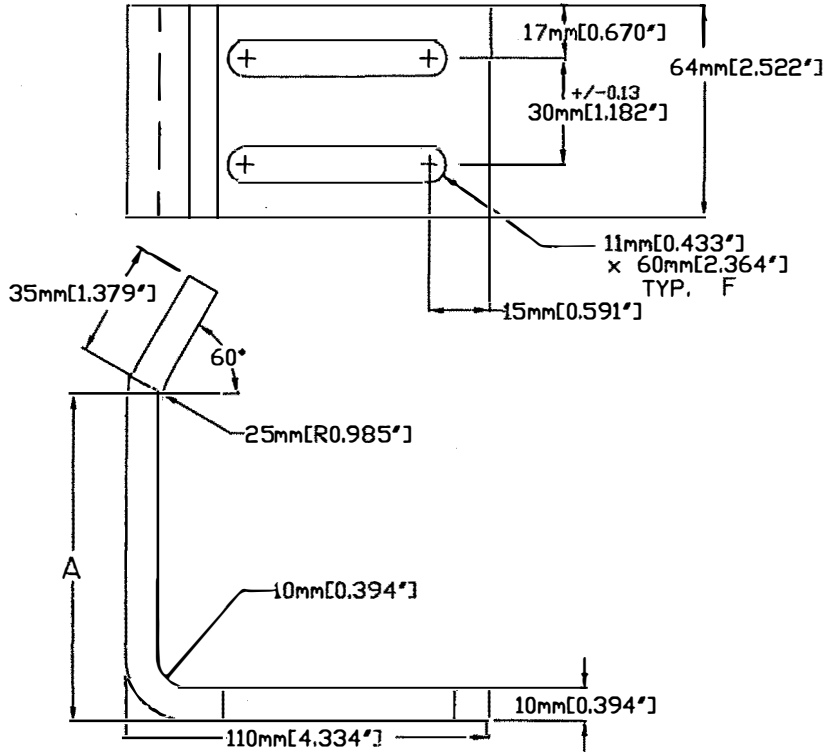

## SPECIFICATIONS & PRICING:

CATALOG		FINISH		A	UNIT PRICE		
TYPE	No.	CODE	DESCRIPTION	METRIC (INCH)			
					QTY: 1-49	QTY: 50-99	QTY: 100 +
U-ARLA	075R	CB	BLACK OXIDE	75MM [2.953"]			
	100R			100MM [3.937"]			
	125R			125MM [4.921"]			
	150R			150MM [5.906"]			
	175R			175MM [6.890"]			
	200R			200MM [7.874"]			
	225R			225MM [8.858"]			
	250R			250MM [9.843"]			

### HOW TO ORDER:

CATALOG TYPE & NO. & FINISH

U-ARLA 075R -CB

### HOW TO ORDER: ALTERATIONS

CATALOG TYPE & NO. & FINISH - ALTERATION

U-ARLA 075R -SR -FC70

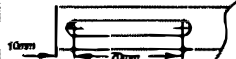
ALTERATIONS	CODE	SPECIFICATIONS	\$ / CODE
	FC	FC70 = 70MM SLOT SLOT DISTANCE TO LOCATOR END WILL BE 10MM	N/C
SAFETY RED COLOR PAINT	SR	REPLACE BLACK OXIDE FINISH WITH SAFETY RED PAINT	

NOTE:  
CHECK AVAILABILITY WHEN ORDERING  
QUANTITIES OVER 99 PIECES.

FREER TOOL AND SUPPLY, 44675 MORLEY DR. CLINTON TOWNSHIP, MI 48036, 586-463-3200

CAD FILE	
DRAWING REV. 11/13/96	
PAGE REV. 9/1/00	
REVISION 1	

PAGE	
G-04	

# ROUGH LOCATORS (1018) U-AWL075R ~ U-AWL250R

NOTE:

**M** Steel(C1018) Black Oxide Finish

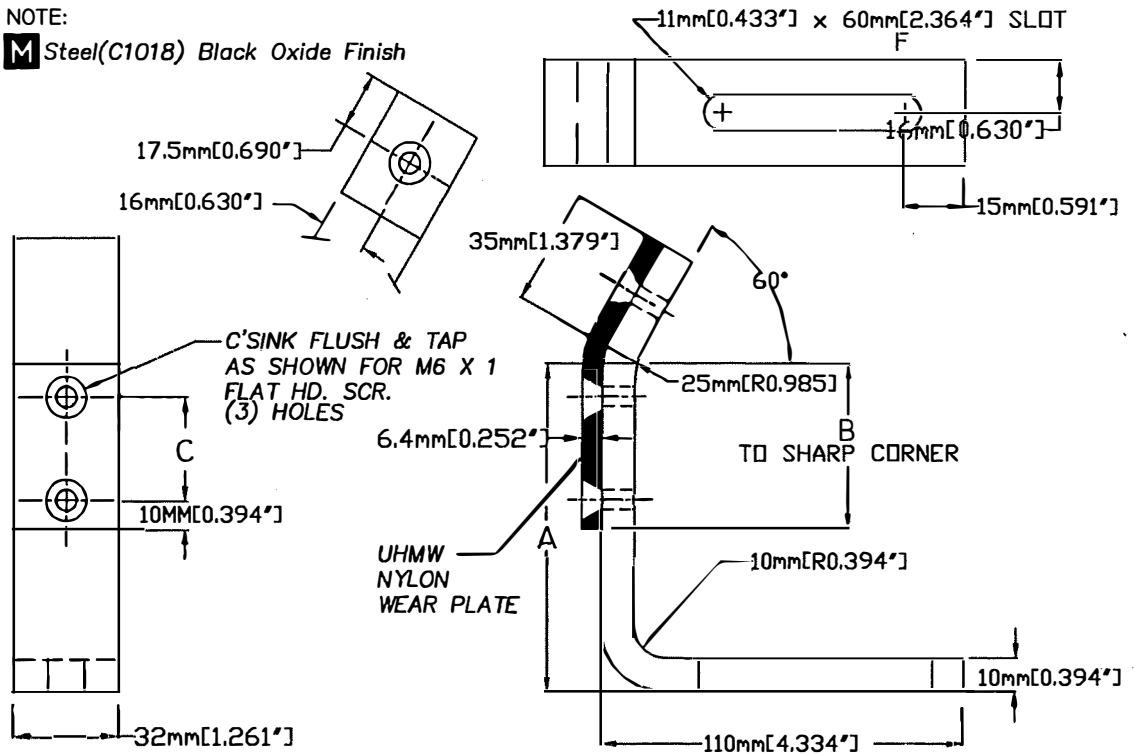

## SPECIFICATIONS & PRICING:

CATALOG		FINISH		A	B	C	UNIT PRICE		
TYPE	No.	CODE	DESCRIPTION	METRIC [INCH]	METRIC [INCH]	METRIC [INCH]	BLACK OXIDE FINISH		
							QTY: 1-49	QTY: 50-99	QTY: 100 +
U-AWL	075R	CB	BLACK OXIDE	75MM [2.953"]	50MM [1.969"]	30MM [1.181"]			
	100R			100MM [3.937"]					
	125R			125MM [4.921"]					
	150R			150MM [5.906"]	100MM [3.937"]	80MM [3.150"]			
	175R			175MM [6.890"]					
	200R			200MM [7.874"]					
	225R			225MM [8.858"]					
	250R			250MM [9.843"]					

### HOW TO ORDER:

CATALOG TYPE & NO. & FINISH

U-AWL 075R -CB

### HOW TO ORDER: ALTERATIONS

CATALOG TYPE & NO. & FINISH - ALTERATION

U-AWL 075R -SR -FC70

ALTERATIONS	CODE	SPECIFICATIONS	\$ / CODE
	FC	FC70 = 70MM SLOT SLOT DISTANCE TO LOCATOR END WILL BE 10MM	N/C
SAFETY RED COLOR PAINT	SR	REPLACE BLACK OXIDE FINISH WITH SAFETY RED PAINT	

NOTE:  
CHECK AVAILABILITY WHEN ORDERING  
QUANTITIES OVER 99 PIECES.

FREER TOOL AND SUPPLY, 44675 MORLEY DR, CLINTON TOWNSHIP, MI 48036, 586-463-3200

CAD FILE	
DRAWING REV. II/13/96	
PAGE REV. 9/1/00	
REVISION I	

PAGE

G-05

# ROUGH LOCATORS (1018) U-AWLA075R ~ U-AWLA250R

NOTE:

**M** Steel(C1018) Black Oxide Finish

11mm[0.433"] x 60mm[2.364"] SLOT  
(2)

17mm[0.670"]

C'SINK FLUSH & TAP  
AS SHOWN FOR M6 X 1  
FLAT HD. SCR.  
(6) HOLES

17.5mm[0.690"]  
17mm[0.670"]

30mm[1.182"]

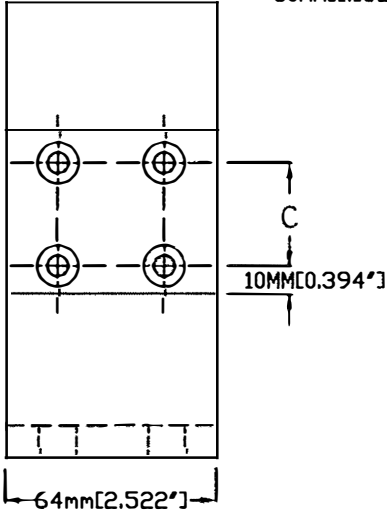
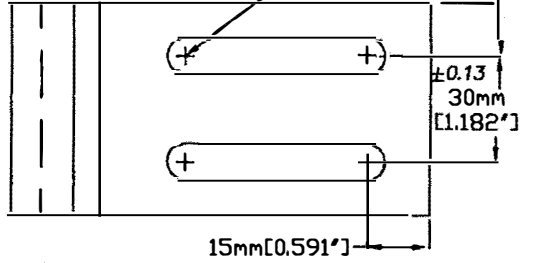

35mm[1.379"]

60°

6.4mm[0.252"]

25mm[R0.985]  
TO SHARP CORNER

UHMW  
NYLON  
WEAR PLATE

10mm[R0.394"]

10mm[0.394"]

110mm[4.334"]

## SPECIFICATIONS & PRICING:

CATALOG		FINISH		A	B	C	UNIT PRICE		
TYPE	No.	CODE	DESCRIPTION	METRIC [INCH]	METRIC [INCH]	METRIC [INCH]	BLACK OXIDE FINISH		
							QTY: 1-49	QTY: 50-99	QTY: 100 +
U-AWLA	075R	CB	BLACK OXIDE	75MM [2.953"]	50MM [1.969"]	30MM [1.181"]			
	100R			100MM [3.937"]					
	125R			125MM [4.921"]					
	150R			150MM [5.906"]					
	175R			175MM [6.890"]	100MM [3.937"]	80MM [3.150"]			
	200R			200MM [7.874"]					
	225R			225MM [8.858"]					
	250R			250MM [9.843"]					

## HOW TO ORDER:

CATALOG TYPE & NO. & FINISH

U-AWLA 075R -CB

## HOW TO ORDER: ALTERATIONS

CATALOG TYPE & NO. & FINISH - ALTERATION

U-AWLA 075R -SR -FC70

ALTERATIONS	CODE	SPECIFICATIONS	\$ / CODE
	FC	FC70 = 70MM SLOT SLOT DISTANCE TO LOCATOR END WILL BE 10MM	N/C
SAFETY RED COLOR PAINT	SR	REPLACE BLACK OXIDE FINISH WITH SAFETY RED PAINT	

NOTE:  
CHECK AVAILABILITY WHEN ORDERING  
QUANTITIES OVER 99 PIECES.

FREER TOOL AND SUPPLY, 44675 MORLEY DR, CLINTON TOWNSHIP, MI 48036, 586-463-3200

CAD FILE	
DRAWING REV. 11/13/96	
PAGE REV. 9/11/00	
REVISION	

PAGE

G-06

# ROUGH LOCATORS (1018) U-AGL175R ~ U-AGL250R

NOTE:

**M** Steel(C1018) Black Oxide Finish

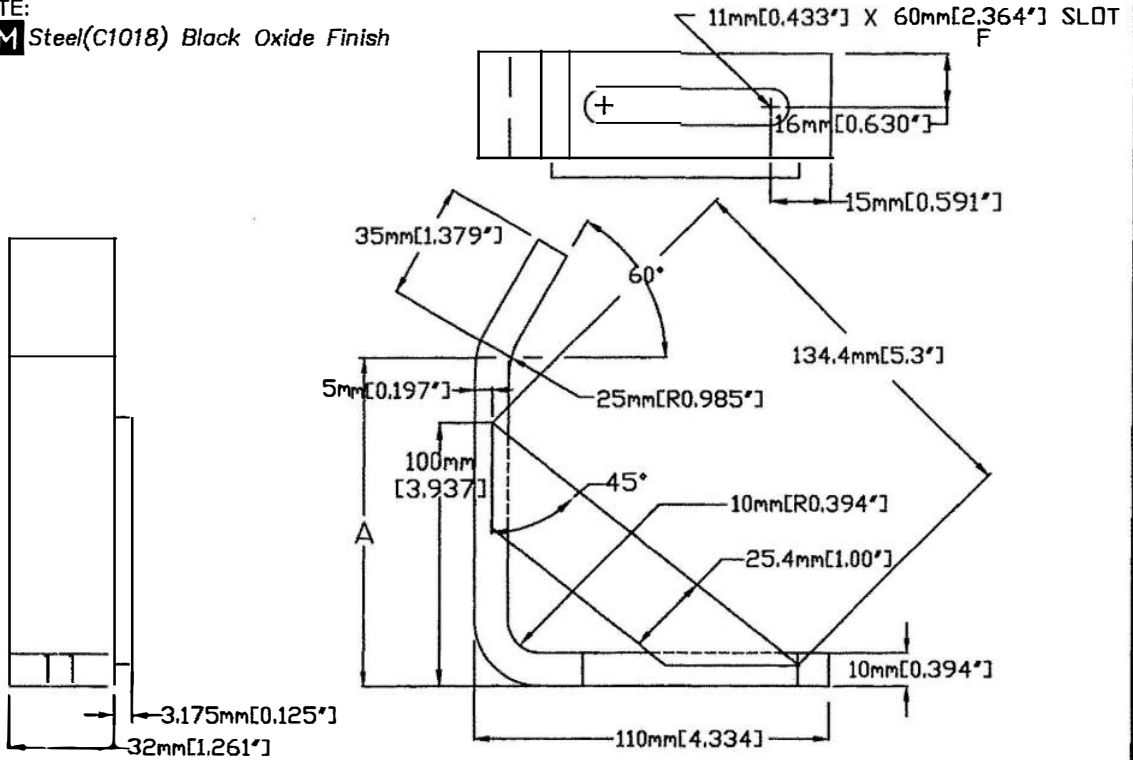

**SPECIFICATIONS & PRICING:**

CATALOG		FINISH		A	UNIT PRICE		
TYPE	No.	CODE	DESCRIPTION	METRIC (INCH)	BLACK OXIDE FINISH		
					QTY: 1-49	QTY: 50-99	QTY: 100 +
U-AGL	175R	CB	BLACK OXIDE	175MM[6.890"]			
	200R			200MM[7.874]			
	225R			225MM[8.858]			
	250R			250MM[9.843]			

**HOW TO ORDER:**

CATALOG TYPE & NO. & FINISH  
U-AGL 175R -CB

**HOW TO ORDER: ALTERATIONS**

CATALOG TYPE & NO. & FINISH - ALTERATION  
U-AGL 175R -SR -FC70

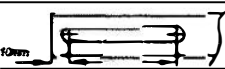
ALTERATIONS	CODE	SPECIFICATIONS	\$ / CODE
	FC	FC70 = 70MM SLOT SLOT DISTANCE TO LOCATOR END WILL BE 10MM	N/C
SAFETY RED COLOR PAINT	SR	REPLACE BLACK OXIDE FINISH WITH SAFETY RED PAINT	

NOTE:  
CHECK AVAILABILITY WHEN ORDERING  
QUANTITIES OVER 99 PIECES.

FREER TOOL AND SUPPLY, 44675 MORLEY DR. [LINTON TOWNSHIP, MI 48036, 586-463-3200

CAD FILE	
DRAWING REV.	11/13/96
PAGE REV.	9/1/00
REVISION	1

# ROUGH LOCATORS (1018) U-AGLA175R ~ U-AGLA250R

NOTE:

**M** Steel(C1018) Black Oxide Finish

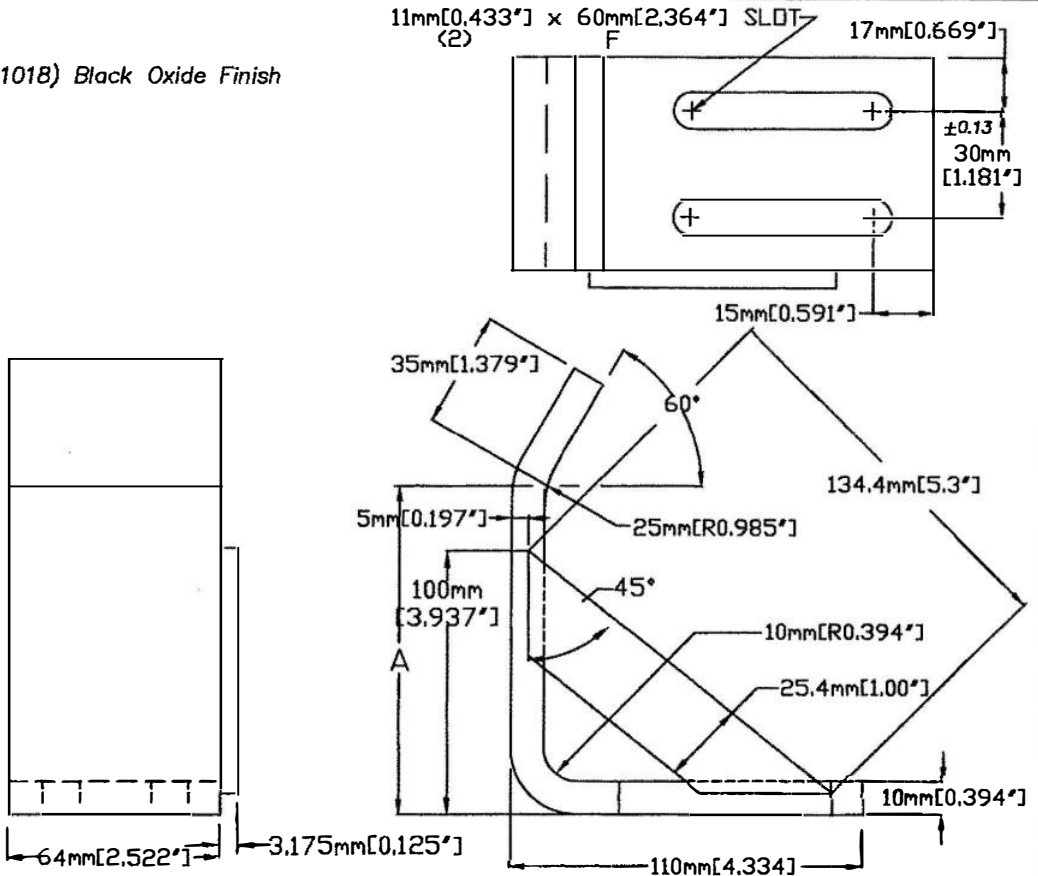

**SPECIFICATIONS & PRICING:**

CATALOG		FINISH		A	UNIT PRICE		
TYPE	No.	CODE	DESCRIPTION	METRIC (INCH)	BLACK OXIDE FINISH		
					QTY: 1-49	QTY: 50-99	QTY: 100 +
U-AGLA	175R	CB	BLACK OXIDE	175MM[6.890"]			
	200R			200MM[7.874"]			
	225R			225MM[8.858"]			
	250R			250MM[9.843"]			

**HOW TO ORDER:**

CATALOG TYPE & NO. & FINISH

U-AGLA 175R -CB

**HOW TO ORDER: ALTERATIONS**

CATALOG TYPE & NO. & FINISH - ALTERATION

U-AGLA 175R -SR -FC70

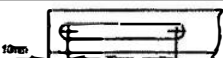
ALTERATIONS	CODE	SPECIFICATIONS	\$ / CODE
	FC	FC70 = 70MM SLOT SLOT DISTANCE TO LOCATOR END WILL BE 10MM	N/C
SAFETY RED COLOR PAINT	SR	REPLACE BLACK OXIDE FINISH WITH SAFTY RED PAINT	

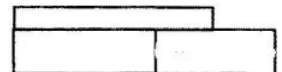

NOTE:  
CHECK AVAILABILITY WHEN ORDERING  
QUANTITIES OVER 99 PIECES.

FREEER TOOL AND SUPPLY, 44675 MORLEY DR, CLINTON TOWNSHIP, MI 48036, 586-463-3200

CAD FILE	
DRAWING REV.	11/13/96
PAGE REV.	9/1/00
REVISION	1

# ROUGH LOCATORS (1018) U-AGW075R ~ U-AGW250R

NOTE:

**M** Steel(C1018) Black Oxide Finish  
 C'SINK FLUSH & TAP  
 AS SHOWN FOR M6 X 1  
 FLAT HD. SCR.  
 (3) HOLES

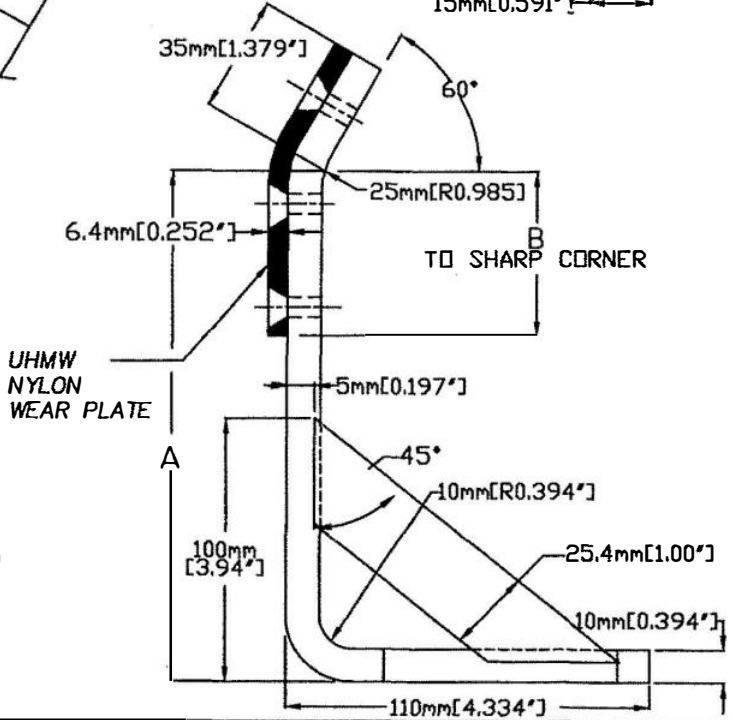
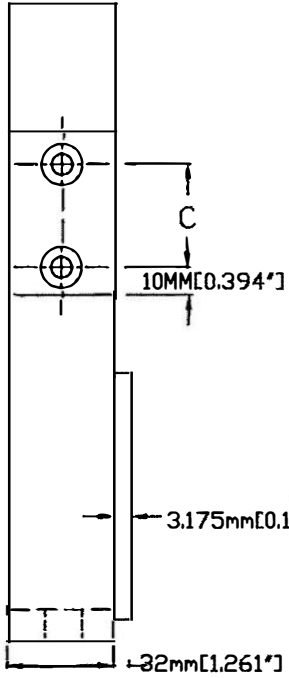
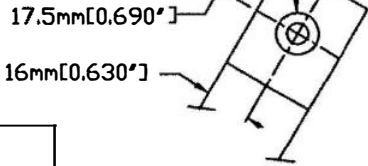
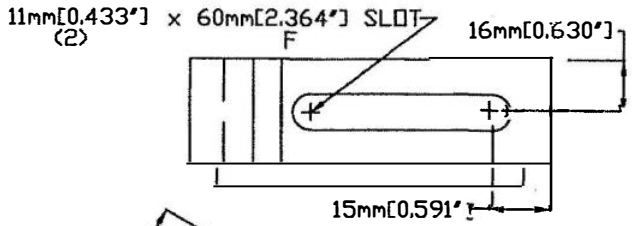

**SPECIFICATIONS & PRICING:**

CATALOG		FINISH		A	B	C	UNIT PRICE		
TYPE	No.	CODE	DESCRIPTION	METRIC [INCH]	METRIC [INCH]	METRIC [INCH]	BLACK OXIDE FINISH		
							Qty: 1-49	QTY: 50-99	QTY: 100 +
U-AGW	175R	CB	BLACK OXIDE	175MM[6.890"]	75MM [2.953"]	55MM [2.165"]			
	200R			200MM[7.874"]					
	225R			225MM[8.858"]	100MM [3.937"]	80MM [3.150"]			
	250R			250MM[9.843"]					

**HOW TO ORDER:**

[CATALOG TYPE & NO. & FINISH]

U-AGW 175R -CB

**HOW TO ORDER: ALTERATIONS**

[CATALOG TYPE & NO. & FINISH - ALTERATION]

U-AGW 175R -SR -FC70

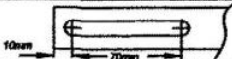
ALTERATIONS	CODE	SPECIFICATIONS	\$ / CODE
	FC	FC70 = 70MM SLOT SLOT DISTANCE TO LOCATOR END WILL BE 10MM	N/C
SAFETY RED COLOR PAINT	SR	REPLACE BLACK OXIDE FINISH WITH SAFETY RED PAINT	

NOTE:  
 CHECK AVAILABILITY WHEN ORDERING  
 QUANTITIES OVER 99 PIECES.

FREEER TOOL AND SUPPLY, 44675 MORLEY DR, CLINTON TOWNSHIP, MI 48036, 586-4 63-3 200

CAD FILE	
DRAWING REV. 11/13/96	
PAGE REV. 9/1/00	
REVISION I	

# ROUGH LOCATORS (1018) U-AGWA075R ~ U-AGWA250R

NOTE:

Steel(C1018) Black Oxide Finish

11mm[0.433"] x 60mm[2.364"] SLOT-  
(2)

17mm[0.670"]

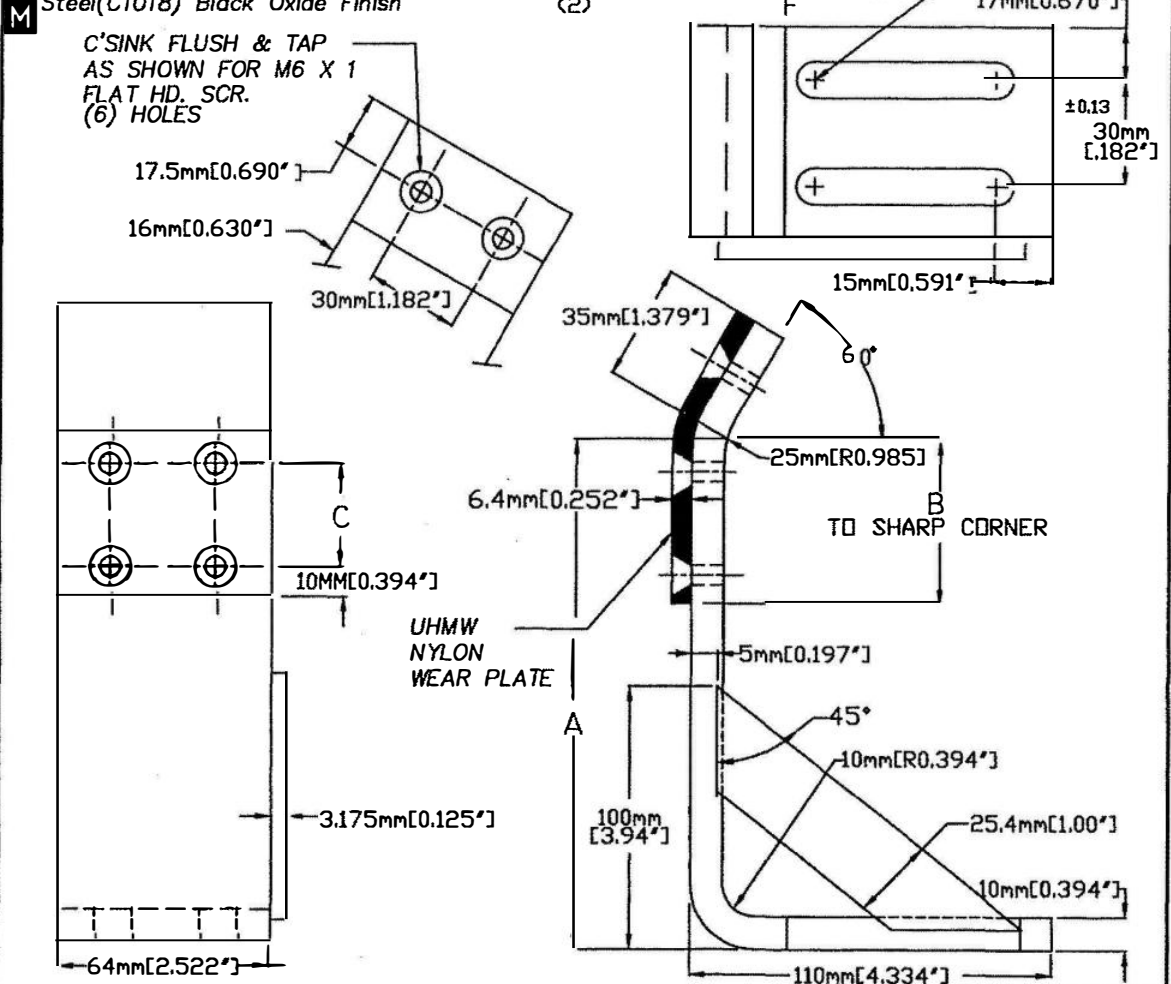

## SPECIFICATIONS & PRICING:

CATALOG		FINISH		A	B	C	UNIT PRICE		
TYPE	No.	CODE	DESCRIPTION	METRIC [INCH]	METRIC [INCH]	METRIC [INCH]	BLACK OXIDE FINISH		
							QTY: 1-49	QTY: 50-99	QTY: 100 +
U-AGWA	175R	CB	BLACK OXIDE	175MM[6.890"]	75MM [2.953"]	55MM [2.165"]			
	200R			200MM[7.874"]					
	225R			225MM[8.858"]	100MM [3.937"]	80MM [3.150"]			
	250R			250MM[9.843"]					

HOW TO ORDER:

[CATALOG TYPE & NO. & FINISH]

U-AGWA 175R -CB

HOW TO ORDER: ALTERATIONS

[CATALOG TYPE & NO. & FINISH - ALTERATION]

U-AGWA 175R -SR -FC70

ALTERATIONS	CODE	SPECIFICATIONS	\$ / CODE
	FC	FC70 = 70MM SLOT SLOT DISTANCE TO LOCATOR END WILL BE 10MM	N/C
SAFETY RED COLOR PAINT	SR	REPLACE BLACK OXIDE FINISH WITH SAFETY RED PAINT	

NOTE:  
CHECK AVAILABILITY WHEN ORDERING  
QUANTITIES OVER 99 PIECES.

FREER TOOL AND SUPPLY, 44675 MORLEY DR, CLINTON TOWNSHIP, MI 48036, 586-463-3200

CAD FILE  
DRAWING REV. 11/13/96

PAGE REV. 9/1/00  
REVISION 1

PAGE

G-10

# ROUGH LOCATORS (1018) U-ARLA075L ~ U-ARLA250L

NOTE:

**M** Steel (C1018)  
Black Oxide Finish

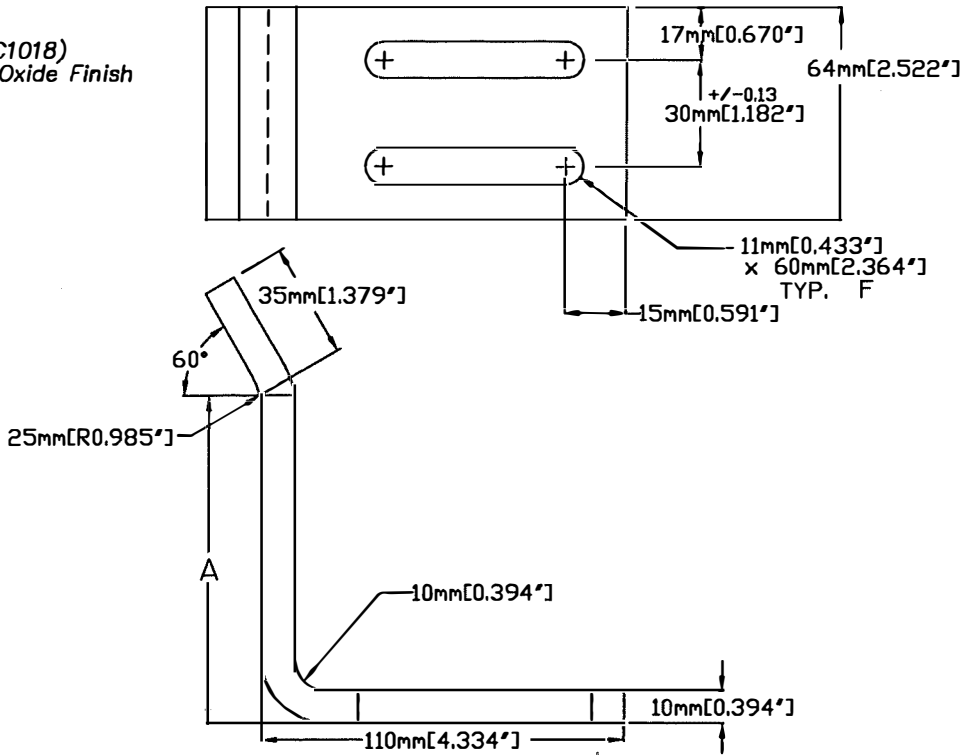

**SPECIFICATIONS & PRICING:**

CATALOG		FINISH		A	UNIT PRICE		
TYPE	No.	CODE	DESCRIPTION	METRIC (INCH)	BOTH PLAIN & BLACK OXIDE FINISH		
					QTY: 1-49	QTY: 50-99	QTY: 100 +
U-ARLA	075L	CB	BLACK OXIDE	75MM [2.953"]			
	100L			100MM [3.937"]			
	125L			125MM [4.921"]			
	150L			150MM [5.906"]			
	175L			175MM [6.890"]			
	200L			200MM [7.874"]			
	225L			225MM [8.858"]			
	250L			250MM [9.843"]			

**HOW TO ORDER:**

CATALOG TYPE & NO. & FINISH

U-ARLA 075L -CB

**HOW TO ORDER: ALTERATIONS**

CATALOG TYPE & NO. & FINISH - ALTERATION

U-ARLA 075L -SR -FC70

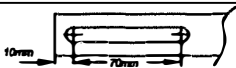
ALTERATIONS	CODE	SPECIFICATIONS	\$ / CODE
	FC	FC70 = 70MM SLOT SLOT DISTANCE TO LOCATOR END WILL BE 10MM	N/C
SAFETY RED COLOR PAINT	SR	REPLACE BLACK OXIDE FINISH WITH SAFETY RED PAINT	

NOTE:  
CHECK AVAILABILITY WHEN ORDERING  
QUANTITIES OVER 99 PIECES.

FREER TOOL AND SUPPLY, 44675 MORLEY DR. CLINTON TOWNSHIP, MI 48036. 586-463-3200

CAD FILE	
DRAWING REV. 11/13/96	
PAGE REV. 9/1/00	
REVISION 1	

PAGE

G-II



# ROUGH LOCATORS (1018) U-AWL075L ~ U-AWL250L

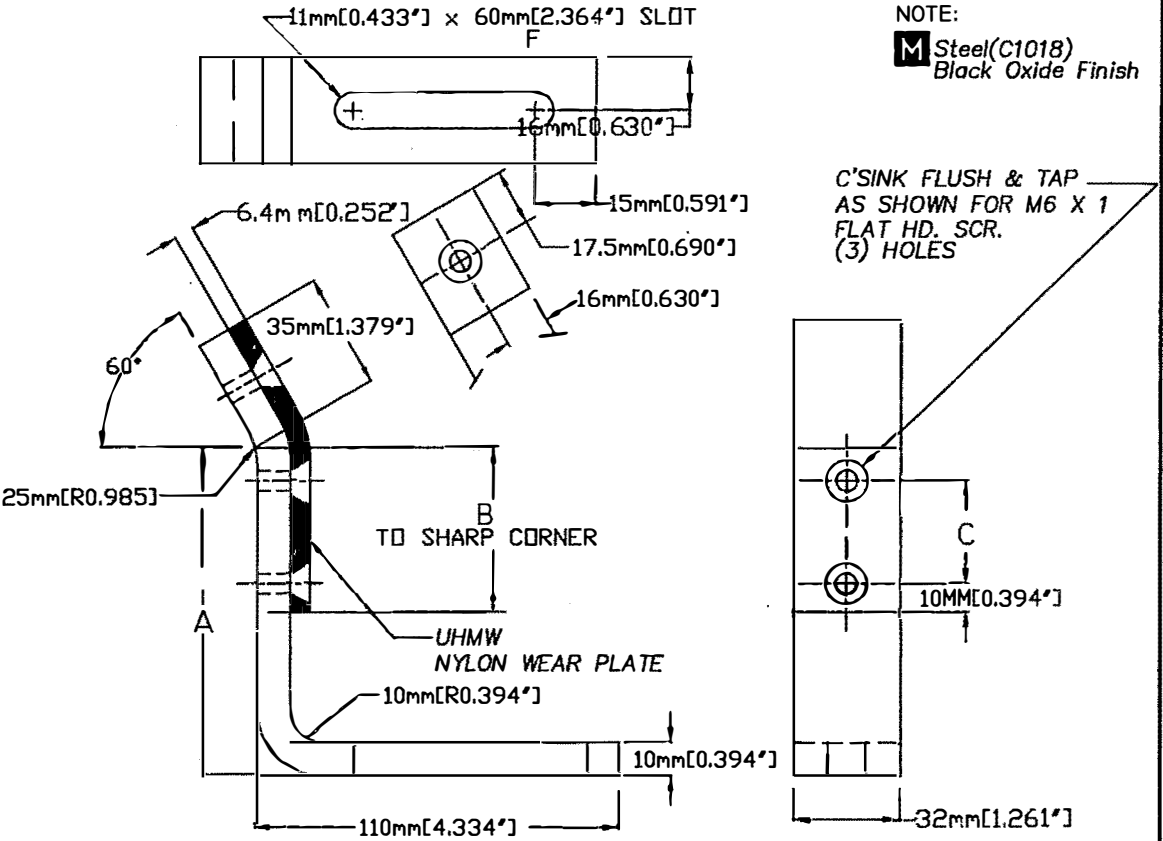

**SPECIFICATIONS & PRICING:**

CATALOG		FINISH		A	B	C	UNIT PRICE		
TYPE	No.	CODE	DESCRIPTION	METRIC [INCH]	METRIC [INCH]	METRIC [INCH]	BLACK OXIDE FINISH		
							QTY: 1-49	QTY: 50-99	QTY: 100 +
U-AWL	075L	CB	BLACK OXIDE	75MM [2.953"]	50MM [1.969"]	30MM [1.181"]			
	100L			100MM [3.937"]					
	125L			125MM [4.921"]					
	150L			150MM [5.906"]					
	175L			175MM [6.890"]	100MM [3.937"]	80MM [3.150"]			
	200L			200MM [7.874"]					
	225L			225MM [8.858"]					
	250L			250MM [9.843"]					

**HOW TO ORDER:**

CATALOG TYPE & NO. & FINISH

U-AWL 075L -CB

**HOW TO ORDER: ALTERATIONS**

CATALOG TYPE & NO. & FINISH - ALTERATION

U-AWL 075L -SR -FC70

ALTERATIONS	CODE	SPECIFICATIONS	\$ / CODE
	FC	FC70 = 70MM SLOT SLOT DISTANCE TO LOCATOR END WILL BE 10MM	N/C
SAFETY RED COLOR PAINT	SR	REPLACE BLACK OXIDE FINISH WITH SAFETY RED PAINT	

**NOTE:**  
 CHECK AVAILABILITY WHEN ORDERING  
 QUANTITIES OVER 99 PIECES.

FREER TOOL AND SUPPLY 44675 MORLEY DR CLINTON TOWNSHIP MI 48036 586 463 3200

CAD FILE	
DRAWING REV. 11/13/96	
PAGE REV. 9/1/00	
REVISION 1	

PAGE  
G-12

# ROUGH LOCATORS (1018) U-AWLA075L ~ U-AWLA250L

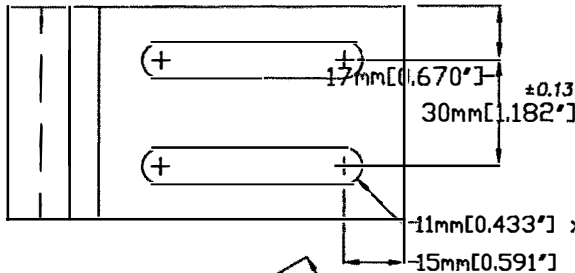

NOTE:  
**M** Steel (C1018)  
 Black Oxide Finish

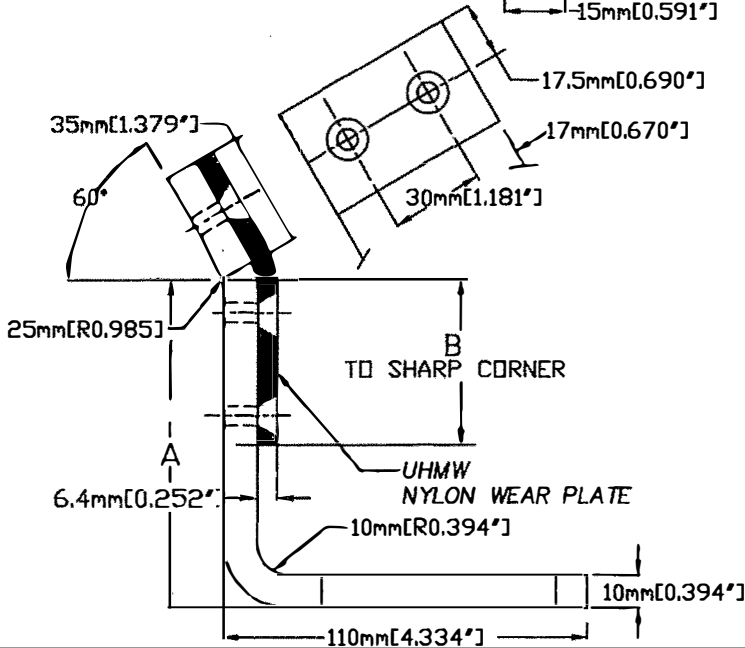

C'SINK FLUSH & TAP  
 AS SHOWN FOR M6 X 1  
 FLAT HD. SCR.  
 (6) HOLES

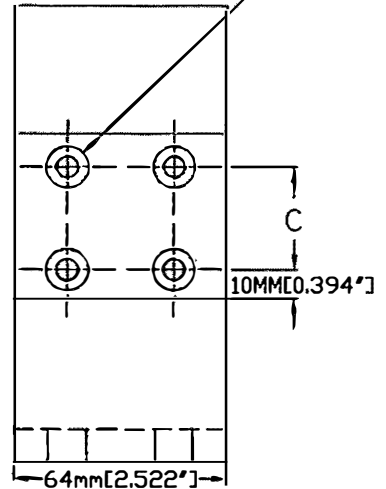

## SPECIFICATIONS & PRICING:

CATALOG		FINISH		A	B	C	UNIT PRICE		
TYPE	No.	CODE	DESCRIPTION	METRIC [INCH]	METRIC [INCH]	METRIC [INCH]	BLACK OXIDE FINISH		
							QTY: 1-49	QTY: 50-99	QTY: 100 +
U-AWLA	075L	CB	BLACK OXIDE	75MM [2.953"]	50MM [1.969"]	30MM [1.181"]			
	100L			100MM [3.937"]					
	125L			125MM [4.921"]					
	150L			150MM [5.906"]	100MM [3.937"]	80MM [3.150"]			
	175L			175MM [6.890"]					
	200L			200MM [7.874"]					
	225L			225MM [8.858"]					
	250L			250MM [9.843"]					

### HOW TO ORDER:

CATALOG TYPE & NO. & FINISH

U-AWLA 075L -CB

### HOW TO ORDER: ALTERATIONS

CATALOG TYPE & NO. & FINISH - ALTERATION

U-AWLA 075L -SR -FC70

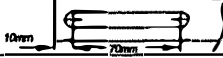
ALTERATIONS	CODE	SPECIFICATIONS	\$ / CODE
	FC	FC70 = 70MM SLOT SLOT DISTANCE TO LOCATOR END WILL BE 10MM	N/C
SAFETY RED COLOR PAINT	SR	REPLACE BLACK OXIDE FINISH WITH SAFETY RED PAINT	

NOTE:  
 CHECK AVAILABILITY WHEN ORDERING  
 QUANTITIES OVER 99 PIECES.

FREER TOOL AND SUPPLY, 44675 MORLEY DR, CLINTON TOWNSHIP, MI 48036, 586-463-3200

CAD FILE	
DRAWING REV. 11/13/96	
PAGE REV. 9/1/00	
REVISION	

PAGE

G-13

# ROUGH LOCATORS (1018) U-AGL175L ~ U-AGL250L

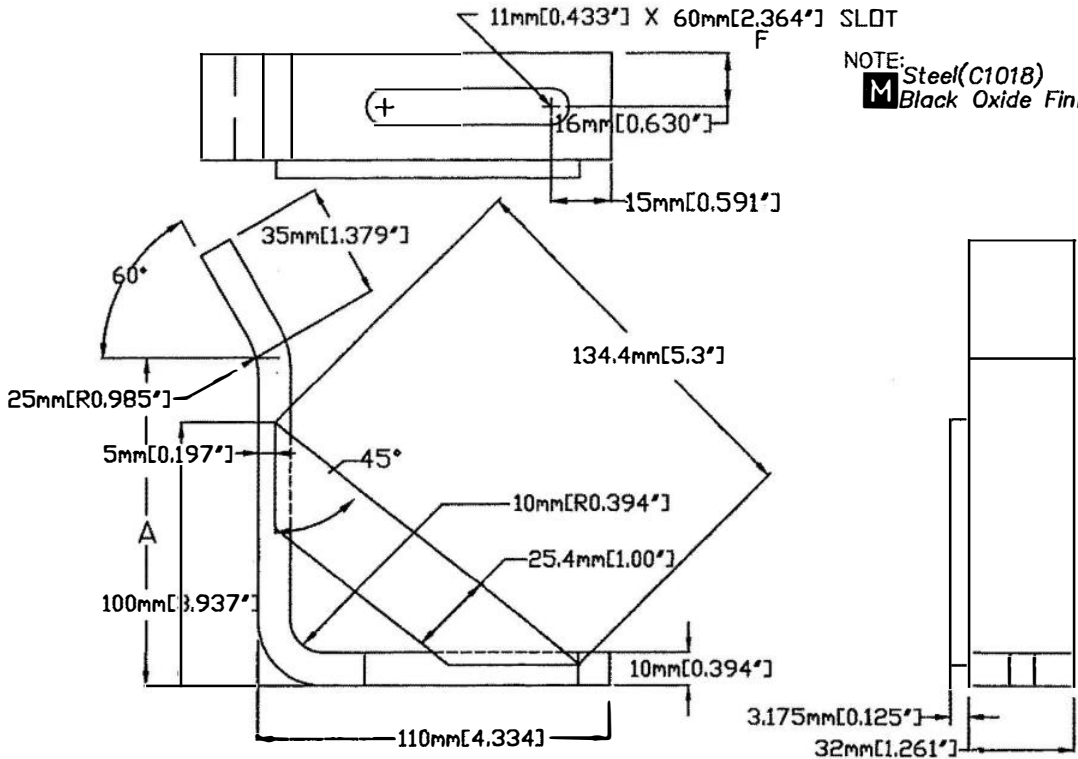

NOTE: **M** Steel (C1018)  
Black Oxide Finish

### SPECIFICATIONS & PRICING:

CATALOG		FINISH		A	UNIT PRICE		
TYPE	No.	CODE	DESCRIPTION	METRIC (INCH)	BLACK OXIDE FINISH		
					QTY: 1-49	QTY: 50-99	QTY: 100 +
U-AGL	175L	CB	BLACK OXIDE	175MM[6.890"]			
	200L			200MM[7.874"]			
	225L			225MM[8.858"]			
	250L			250MM[9.843"]			

#### HOW TO ORDER:

CATALOG TYPE & NO. & FINISH

U-AGL 175L -CB

#### HOW TO ORDER: ALTERATIONS

CATALOG TYPE & NO. & FINISH - ALTERATION

U-AGL 175L -SR -FC70

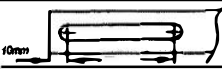
ALTERATIONS	CODE	SPECIFICATIONS	\$ / CODE
	FC	FC70 = 70MM SLOT SLOT DISTANCE TO LOCATOR END WILL BE 10MM	N/C
SAFETY RED COLOR PAINT	SR	REPLACE BLACK OXIDE FINISH WITH SAFETY RED PAINT	

NOTE:  
CHECK AVAILABILITY WHEN ORDERING  
QUANTITIES OVER 99 PIECES.

FREE TOOL AND SUPPLY, 44675 MDRLEY DR, CLINTON TOWNSHIP, MI 48036, 586-463-3200

CAD FILE	
DRAWING REV.	

# ROUGH LOCATORS (1018) U-AGLA175L ~ U-AGLA250L

11mm[0.433"] x 60mm[2.364"] SLOT  
(2)  
F

17mm[0.670"]

NOTE:

**M** Steel (C1018)  
Black Oxide Finish

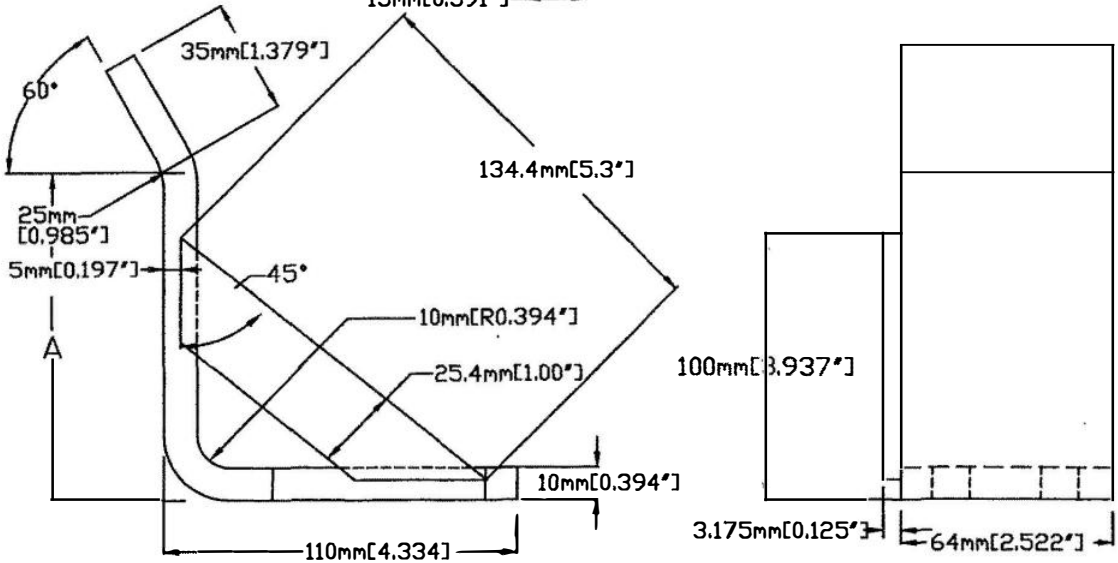
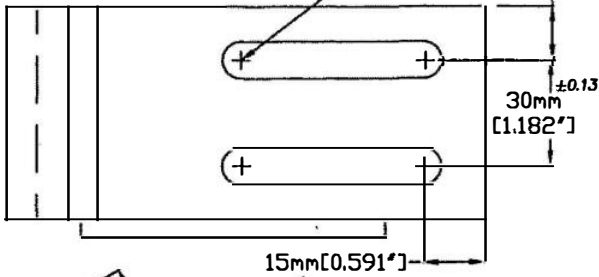

## SPECIFICATIONS & PRICING:

CATALOG		FINISH		A	UNIT PRICE		
TYPE	No.	CODE	DESCRIPTION	METRIC (INCH)	BLACK OXIDE FINISH		
					QTY: 1-49	QTY: 50-99	QTY: 100 +
U-AGLA	175L	CB	BLACK OXIDE	175MM[6.890"]	31.00	30.44	28.61
	200L			200MM[7.874"]			
	225L			225MM[8.858"]			
	250L			250MM[9.843"]			

### HOW TO ORDER:

CATALOG TYPE & NO. & FINISH

U-AGLA 175L -CB

### HOW TO ORDER: ALTERATIONS

CATALOG TYPE & NO. & FINISH - ALTERATION

U-AGLA 175L -SR -FC70

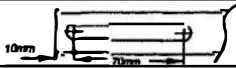
ALTERATIONS	CODE	SPECIFICATIONS	\$ / CODE
	FC	FC70 = 70MM SLOT SLOT DISTANCE TO LOCATOR END WILL BE 10MM	N/C
SAFETY RED COLOR PAINT	SR	REPLACE BLACK OXIDE FINISH WITH SAFETY RED PAINT	4.00

NOTE:  
CHECK AVAILABILITY WHEN ORDERING  
QUANTITIES OVER 99 PIECES.

FREER TOOL AND SUPPLY, 44675 MORLEY DR. [LINTON TOWNSHIP, MI 48036, 586-463-3200

CAD FILE	
DRAWING REV.	11/13/96
PAGE REV.	9/1/00
REVISION	1

PAGE

G-15

# ROUGH LOCATORS (1018) U-AGW175L ~ U-AGW250L

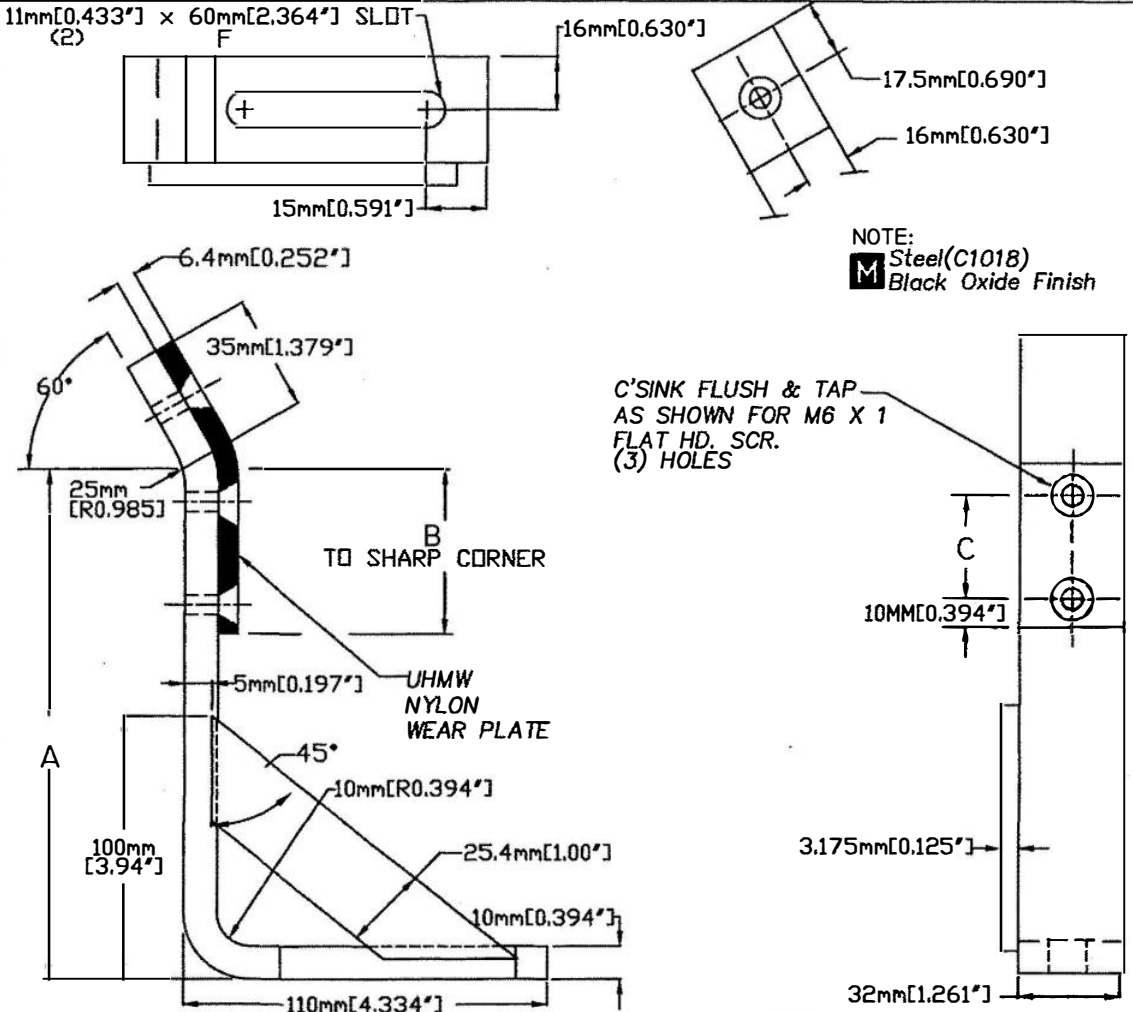

## SPECIFICATIONS & PRICING:

CATALOG		FINISH		A	B	C	UNIT PRICE		
TYPE	No.	CODE	DESCRIPTION	METRIC [INCH]	METRIC [INCH]	METRIC [INCH]	BLACK OXIDE FINISH		
							QTY: 1-49	QTY: 50-99	QTY: 100 +
U-AGW	175L	CB	BLACK OXIDE	175MM[6.890"]	75MM [2.953"]	55MM [2.165"]			
	200L			200MM[7.874"]					
	225L			225MM[8.858"]	100MM [3.937"]	80MM [3.150"]			
	250L			250MM[9.843"]					

## HOW TO ORDER:

CATALOG TYPE & NO. & FINISH  
U-AGW 175L -CB

## HOW TO ORDER: ALTERATIONS

CATALOG TYPE & NO. & FINISH - ALTERATION  
U-AGW 175L -SR -FC70

ALTERATIONS	CODE	SPECIFICATIONS	\$ / CODE
10mm	FC	FC70 = 70MM SLOT SLOT DISTANCE TO LOCATOR END WILL BE 10MM	N/C
SAFETY RED COLOR PAINT	SR	REPLACE BLACK OXIDE FINISH WITH SAFETY RED PAINT	

NOTE:  
CHECK AVAILABILITY WHEN ORDERING  
QUANTITIES OVER 99 PIECES.

FREER TOOL AND SUPPLY, 44675 MORLEY DR, CLINTON TOWNSHIP, MI 48036, 586-463-3200

CAD FILE	
DRAWING REV.	11/13/96
PAGE REV.	9/1/00
REVISION	

PAGE

G-16

# ROUGH LOCATORS (1018) U-AGWAI75L ~ U-AGWA250L

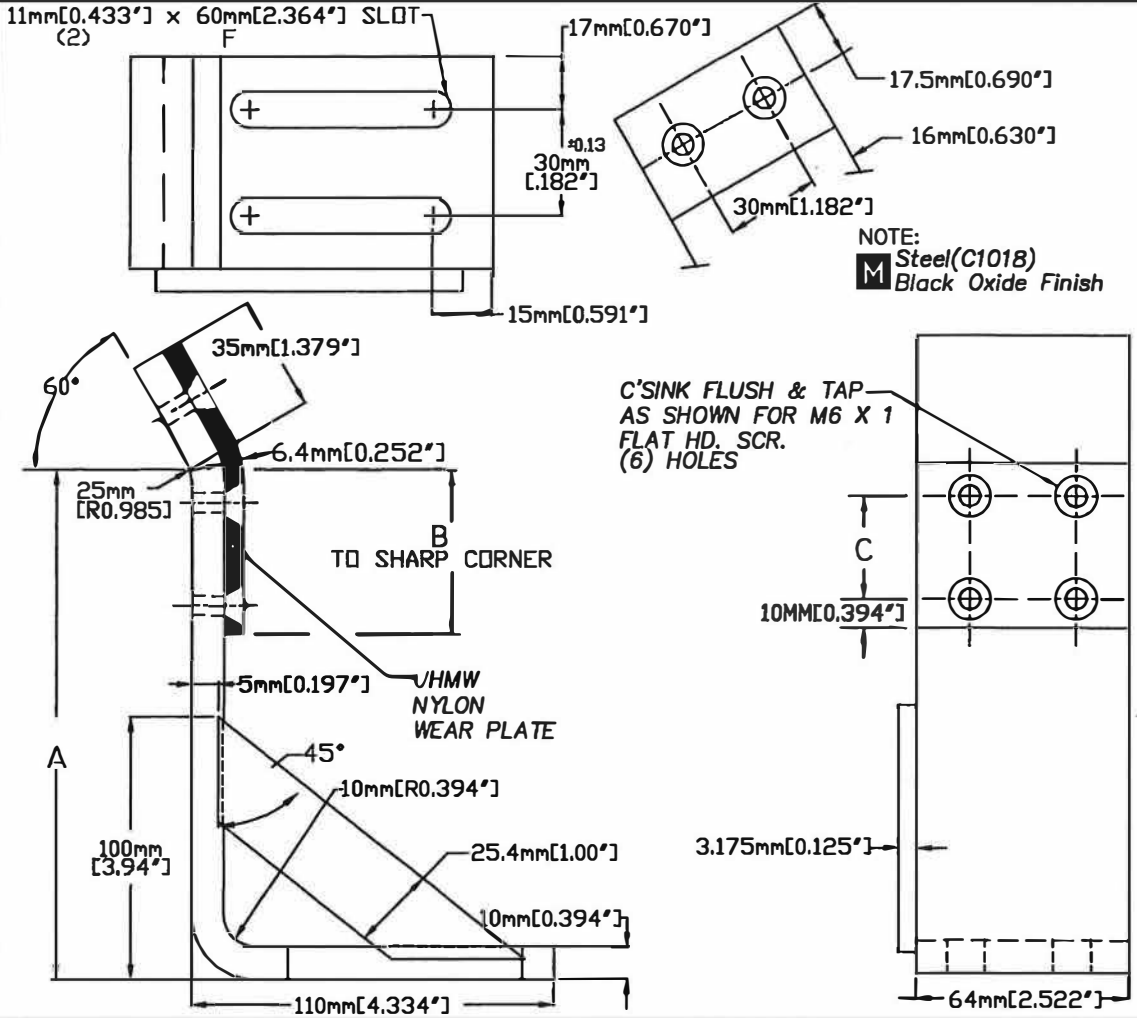

**NOTE:**  
 Steel (C1018)  
 Black Oxide Finish

**SPECIFICATIONS & PRICING:**

CATALOG		FINISH		A	B	C	UNIT PRICE		
TYPE	No.	CODE	DESCRIPTION	METRIC [INCH]	METRIC [INCH]	METRIC [INCH]	BLACK OXIDE FINISH		
							QTY: 1-49	QTY: 50-99	QTY: 100 +
U-AGWA	175L	CB	BLACK OXIDE	175MM [6.890"]	75MM [2.953"]	55MM [2.165"]			
	200L			200MM [7.874"]					
	225L			225MM [8.858"]	100MM [3.937"]	80MM [3.150"]			
	250L			250MM [9.843"]					

**HOW TO ORDER:**  
CATALOG TYPE & NO. & FINISH  
 U-AGWA 175L -CB

**HOW TO ORDER: ALTERATIONS**  
CATALOG TYPE & NO. & FINISH - ALTERATION  
 U-AGWA 175L -SR -FC70

ALTERATIONS	CODE	SPECIFICATIONS	\$ / CODE
	FC	FC70 = 70MM SLOT SLOT DISTANCE TO LOCATOR END WILL BE 10MM	N/C
SAFETY RED COLOR PAINT	SR	REPLACE BLACK OXIDE FINISH WITH SAFETY RED PAINT	

**NOTE:**  
 CHECK AVAILABILITY WHEN ORDERING  
 QUANTITIES OVER 99 PIECES.

FREER TOOL AND SUPPLY, 44675 MORLEY DR. CLINTON TOWNSHIP, MI 48036. 586-463-3200

# ROUGH LOCATORS (1018) U-ARLB140 ~ U-ARLB320

NOTE:

**M** Steel(C1018)  
Black Oxide Finish

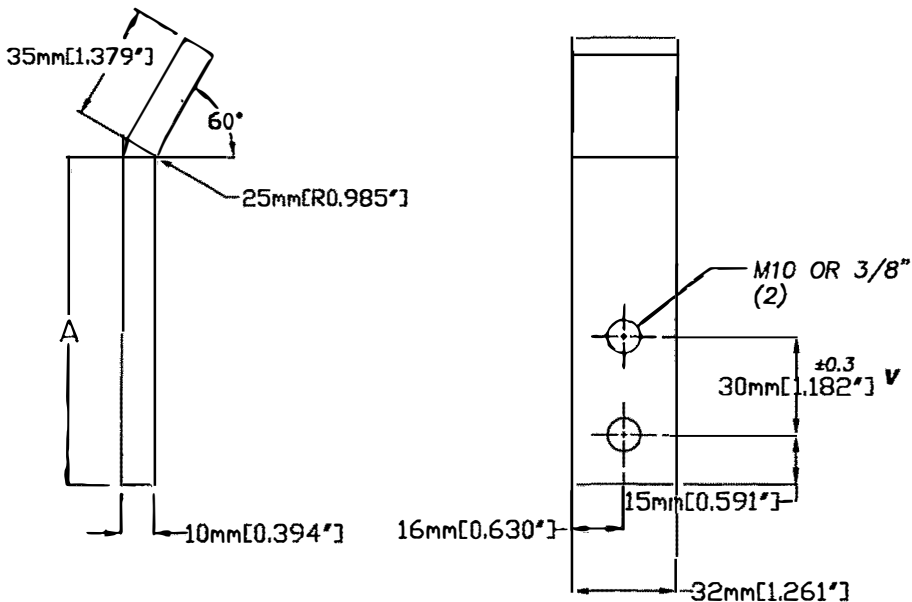

**SPECIFICATIONS & PRICING:**

CATALOG		FINISH		A	UNIT PRICE			
TYPE	NO.	CODE	DESCRIPTION	METRIC (INCH)	BLACK OXIDE FINISH			
					QTY: 1-19	QTY: 20-49	QTY: 50-99	QTY: 100 +
U-ARLB	145	CB	BLACK OXIDE	145MM[5.709"]				
	170			170MM[6.693"]				
	195			195MM [7.683"]				
	220			220MM[8.661"]				
	245			245MM[9.646"]				
	270			270MM[10.630"]				
	298			298MM[11.732"]				
	320			320MM[12.598"]				

**HOW TO ORDER:**

CATALOG TYPE & NO. & FINISH

U-ARLB 145 -CB

**HOW TO ORDER: ALTERATIONS**

CATALOG TYPE & NO. & FINISH - ALTERATION

U-ARLB 145 -SR -FC70

ALTERATIONS	CODE	SPECIFICATIONS	\$ / CODE
	VC	VC45 = 45MM SLOT SLOT DISTANCE TO LOCATOR END WILL BE 15MM	N/C
SAFETY RED COLOR PAINT	SR	REPLACE BLACK OXIDE FINISH WITH SAFETY RED PAINT	

NOTE:  
CHECK AVAILABILITY WHEN ORDERING  
QUANTITIES OVER 99 PIECES.

FREER TOOL AND SUPPLY, 44675 MORLEY DR, CLINTON TOWNSHIP, MI 48036, 586-463-3200

CAD FILE	
DRAWING REV. 11/13/96	
PAGE REV. 9/1/00	
REVISION	

PAGE

G-18

# ROUGH LOCATORS (1018) U-ARLC075R ~ U-ARLC250R

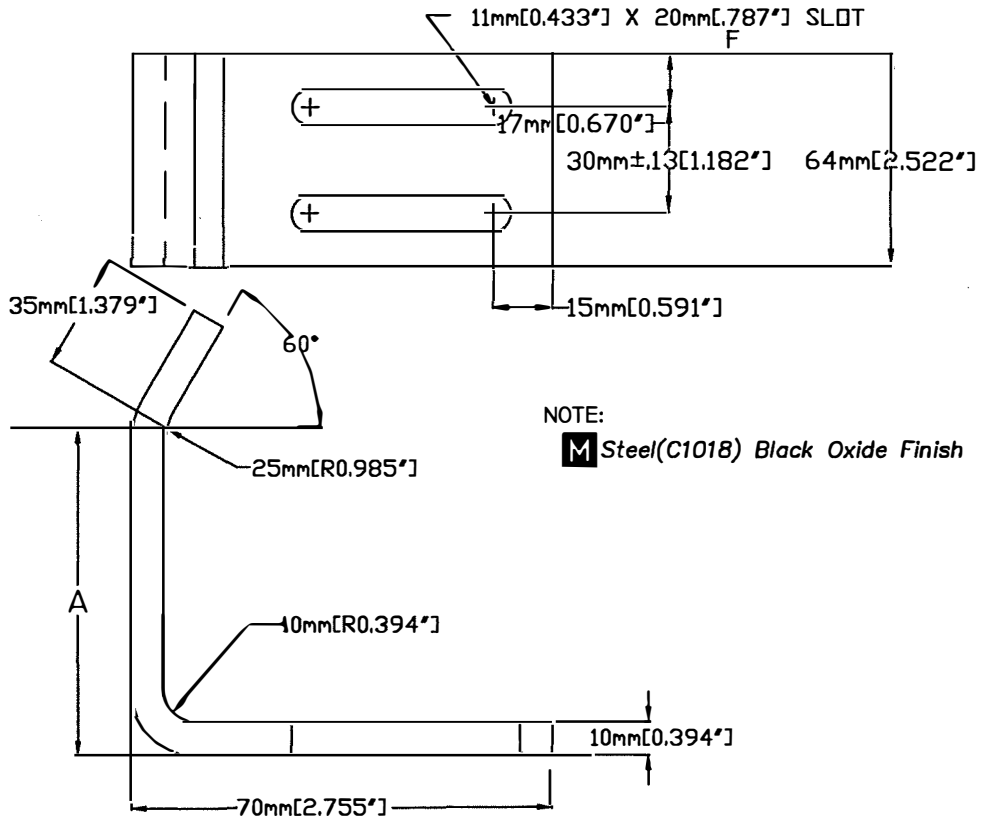

NOTE:

**M** Steel(C1018) Black Oxide Finish

## SPECIFICATIONS & PRICING:

CATALOG		FINISH		A	UNIT PRICE		
TYPE	No.	CODE	DESCRIPTION	METRIC (INCH)	QTY: 1-49	QTY: 50-99	QTY: 100+
U-ARLC	075R	CB	BLACK OXIDE	75MM [2.953"]			
	100R			100MM [3.937"]			
	125R			125MM [4.921"]			
	150R			150MM [5.906"]			
	175R			175MM [6.890"]			
	200R			200MM [7.874"]			
	225R			225MM [8.858"]			
	250R			250MM [9.843"]			

### HOW TO ORDER:

CATALOG TYPE & NO. & FINISH

U-ARL 075R -CB

### HOW TO ORDER: ALTERATIONS

CATALOG TYPE & NO. & FINISH - ALTERATION

U-ARL 075R -CB -FC70

NOTE:  
CHECK AVAILABILITY WHEN ORDERING  
QUANTITIES OVER 99 PIECES.

ALTERATIONS	CODE	SPECIFICATIONS	\$ / CODE
	FC	FC70 = 70MM SLOT SLOT DISTANCE TO LOCATOR END WILL BE 10MM	N/C
SAFETY RED COLOR PAINT	SR	REPLACE BLACK OXIDE FINISH WITH SAFETY RED PAINT	

FREE TOOL AND SUPPLY, 44675 MORLEY DR, CLINTON TOWNSHIP, MI 48036, 586-463-3200

CAD FILE	
DRAWING REV.	11/13/96
PAGE REV.	9/1/00
REVISION	1

PAGE

G-19



# ROUGH LOCATORS (1018) U-ARLC075L ~ U-ARLC250L

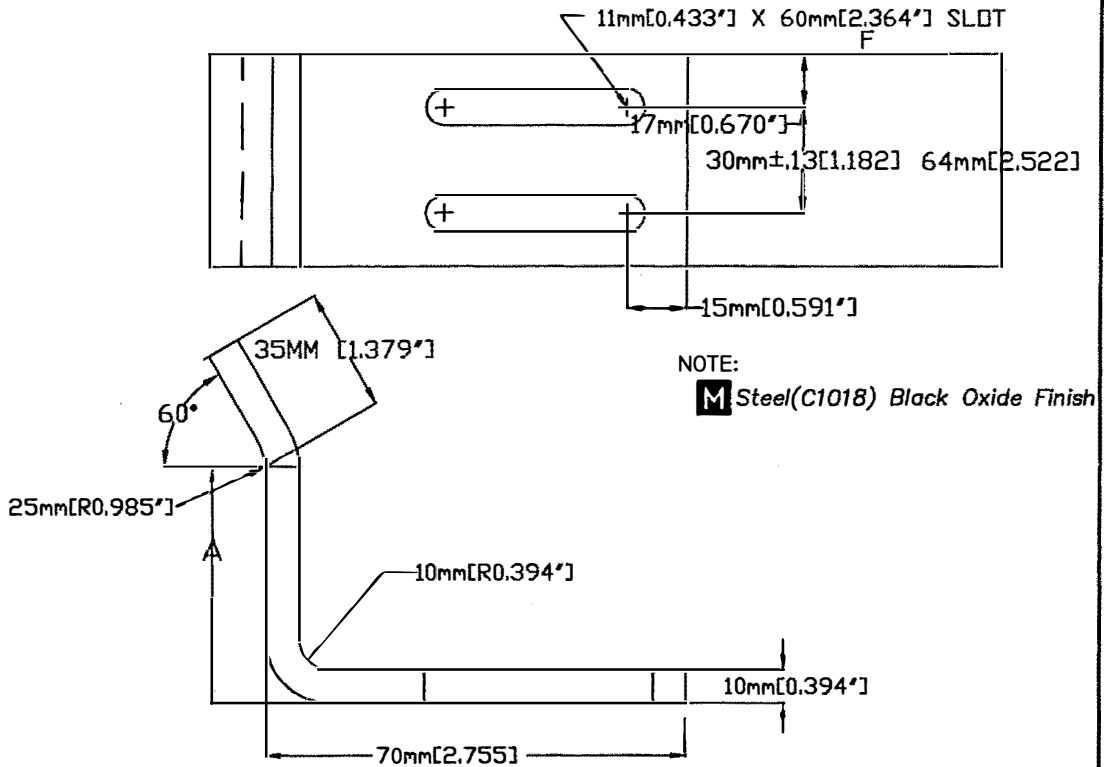

## SPECIFICATIONS & PRICING:

CATALOG		FINISH		A	UNIT PRICE		
TYPE	No.	CODE	DESCRIPTION	METRIC (INCH)	QTY: 1-49	QTY: 50-99	QTY: 100+
U-ARLC	075L	CB	BLACK OXIDE	75MM [2.953"]			
	100L			100MM [3.937"]			
	125L			125MM [4.921"]			
	150L			150MM [5.906"]			
	175L			175MM [6.890"]			
	200L			200MM [7.874"]			
	225L			225MM [8.858"]			
	250L			250MM [9.843"]			

### HOW TO ORDER:

CATALOG TYPE & NO. & FINISH  
 U-ARLC 075L -CB

### HOW TO ORDER: ALTERATIONS

CATALOG TYPE & NO. & FINISH - ALTERATION  
 U-ARLC 075L -CB -FC70

NOTE:  
 CHECK AVAILABILITY WHEN ORDERING  
 QUANTITIES OVER 99 PIECES.

ALTERATIONS	CODE	SPECIFICATIONS	\$ / CODE
	FC	FC70 = 70MM SLOT SLOT DISTANCE TO LOCATOR END WILL BE 10MM	N/C
SAFETY RED COLOR PAINT	SR	REPLACE BLACK OXIDE FINISH WITH SAFETY RED PAINT	

FREER TOOL AND SUPPLY, 44675 MORLEY DR. CLINTON TOWNSHIP, MI 48036. 586-463-3200

CAD FILE	
DRAWING REV. 11/13/96	
PAGE REV. 9/1/00	
REVISION 1	

PAGE	
G-20	