

STOP BLOCKS INDEX

PAGE	DATE	NAAMS CODE	DESCRIPTION
L-1	05/25/12		Stop Blocks Index
L-2	05/25/12	ASC018 – ASC091	Stop Blocks Crowned
L-3	05/25/12	ASF018 – ASF091	Stop Blocks Flat
L-4	04/07/15	ASF001	Stop Block Flat
L-5	04/07/15	ASF002	Stop Block Flat

STOP BLOCKS CROWNED

Tolerances: METRIC

1 PLACE ± 0.3

2 PLACE ± 0.03

Identify with NAAMS CODE number as shown **XXX**.

Black Oxide Finish.

MATERIAL: STEEL SAE 1060 – Flame Harden Cross-Hatched
Surface 3.0 DEEP MIN. Rc 55-60.

SEE PAGE B-1.1 FOR GLOBAL MATERIALS CHART

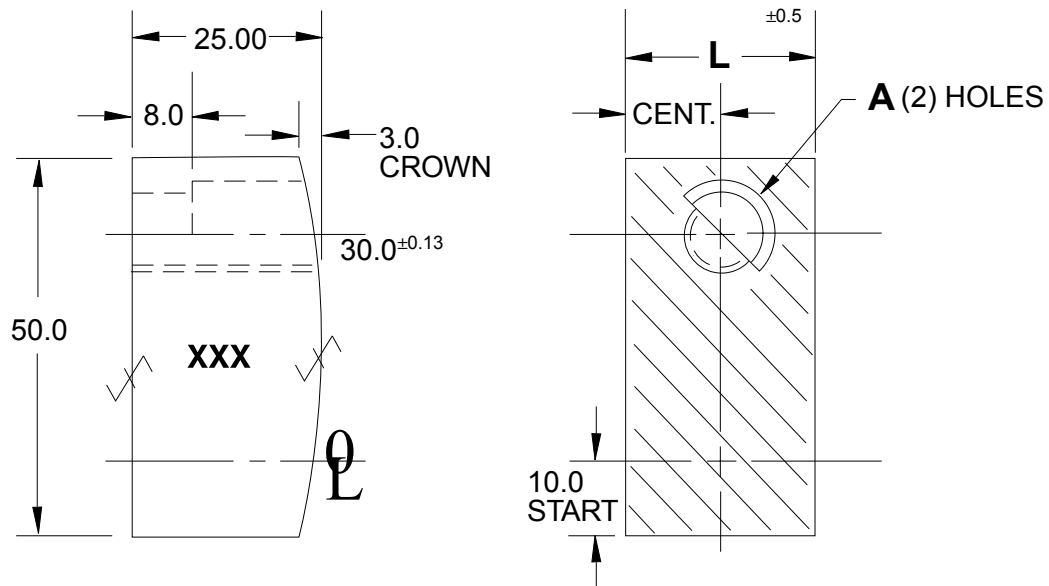

NAAMS CODE	L	A
ASC018	20	Drill & C/Bore for M8 Soc Hd Scr
ASC019	20	M8 x 1.25
ASC020	25	Drill & C/Bore for M10 Soc Hd Scr
ASC021	25	M10 x 1.5
ASC060	60	Drill & C/Bore for M10 Soc Hd Scr
ASC061	60	M10 x 1.5
ASC090	90	Drill & C/Bore for M10 Soc Hd Scr
ASC091	90	M10 x 1.5

A
B

D

C