

# METRIC MASTER BLOCK AMB003



Assembly

08/13/07

Tolerances: 1 PLACE  $\pm 0.3$   
2 PLACE  $\pm 0.03$   
3 PLACE  $\pm 0.01$

STK: 1-1/2" x 2-1/8" x 75 LG.

SAE 01 OIL-HARDENING COLD-WORK TOOL STEEL  
HARDEN 50-55 R.C. & GRIND, BLACK OXIDE FINISH

• ALL DIMENSIONS ARE mm.

• SURFACES TO BE FLAT, PARALLEL, AND PERPENDICULAR TO WITHIN 0.005 T.I.R.

•  $\varnothing 6.350$  HOLES TO BE PERPENDICULAR TO SURFACE WITHIN 0.005 T.I.R.

• ALL GROUND SURFACES ARE TO BE 0.4 MICROMETERS.

SEE PAGE B-1.1 FOR GLOBAL MATERIALS CHART

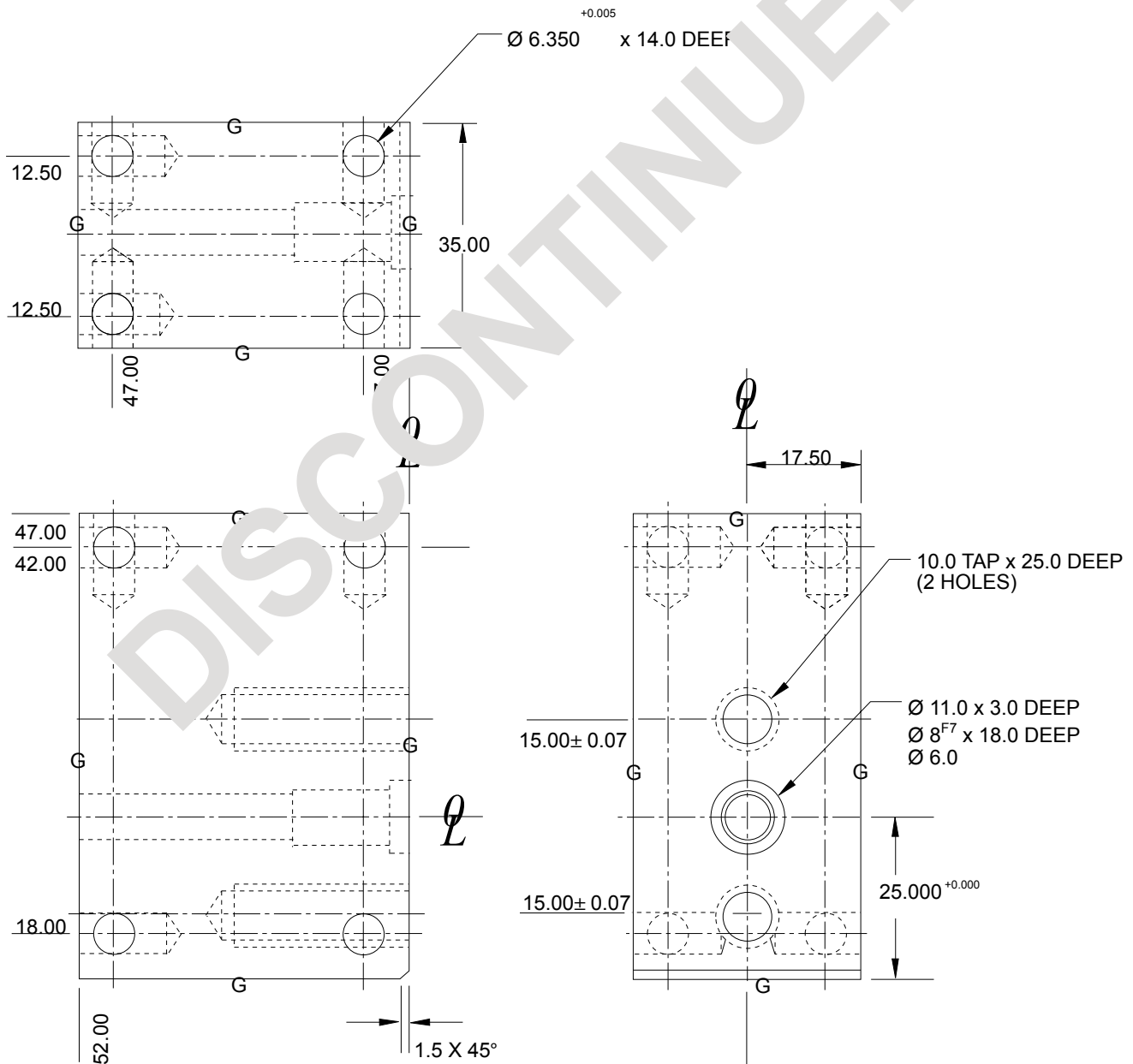

B

A

A