

METRIC MASTER BLOCK AMB001

GLOBAL STANDARD COMPONENTS



Assembly

08/13/07

Tolerances: 1 PLACE ± 0.3
2 PLACE ± 0.03
3 PLACE ± 0.01

STK: 1-1/2" x 2-1/8" x 75 LG.
SAE O1 OIL-HARDENING COLD-WORK TOOL STEEL
HARDEN 50-55 R.C. & GRIND, BLACK OXIDE FINISH

- ALL DIMENSIONS ARE mm.
 - SURFACES TO BE FLAT, PARALLEL, AND PERPENDICULAR TO WITHIN 0.005 T.I.R.
 - $\varnothing 6.350$ HOLES TO BE PERPENDICULAR TO SURFACE WITHIN 0.005 T.I.R.
 - ALL GROUND SURFACES ARE TO BE 0.4 MICROMETERS.
- SEE PAGE B-1.1 FOR COORDINATE MATERIALS CHART

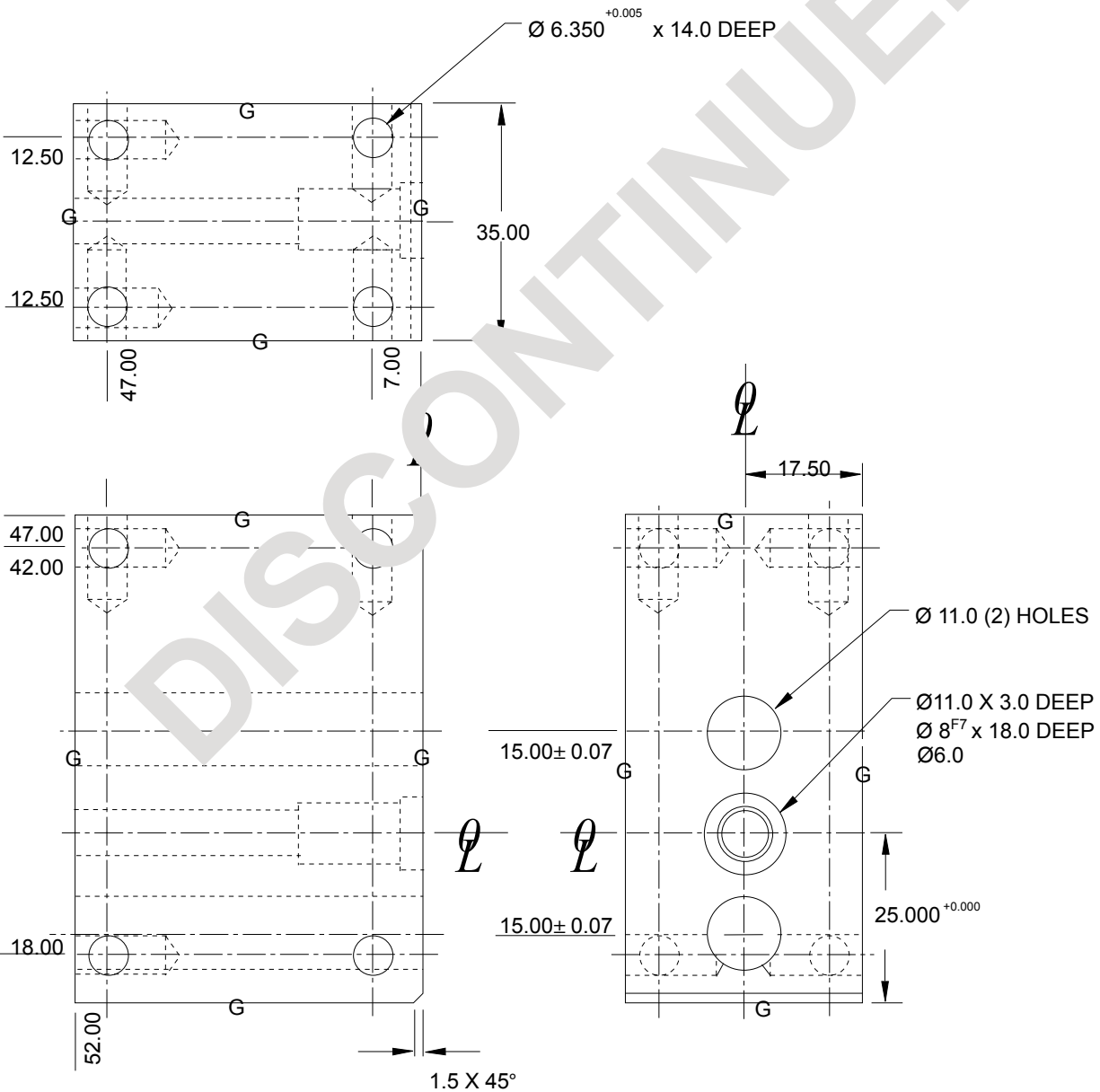

B

A

A