

Series 2005 Product Overview

Features:

- Increased handle clearance reduces pinch points
- Mounting pattern interchangeable with Model 205 with 3 times the holding capacity

Applications:

- Assembly
- Closures

Also Available:

See page 8.1 for accessories
Accommodates M4 or #8 spindle accessory

Covered under one year or more U.S./International Patents

2005-U
U-Bar



2005-S
Solid Bar



Series 2005 Technical Information

Model	Max. Holding Capacity	Clamp Bar Opening (+10°)	Handle Opening (+10°)	Weight	Accessories (Supplied)	
					Spindle Assembly	Flanged Washers
2005-U	800 N [180 lbf]	74°	62°	0,05kg [0.10lb]	205208-M	105106
2005-S	450 N [100 lbf]					--

Series 2005 Holding Capacities

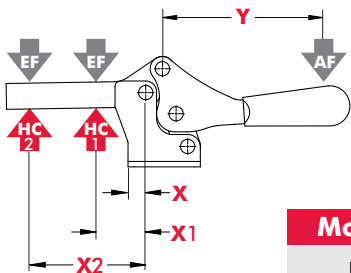

Model	X	X1	X2	Y	±HC1	±HC2	±EF(X1):AF	±EF(X2):AF
U	[0.48]	[0.62] 15,8	[1.05] 26,7	[1.20]	[180lbf.] 800N	[120lbf.] 530N	5:1	2.5:1
S	12,2	--	[1.15] 29,2	30,5	--	[100lbf.] 450N	--	

Dimensions shown "mm [inch]" ± HC = Holding Capacity, EF = Exerting Force, AF = Applied Force
Refer to page 20.5 for additional information.



Series 2005 Standard Clamp Dimensions -U/-S

2005-U
U-Bar

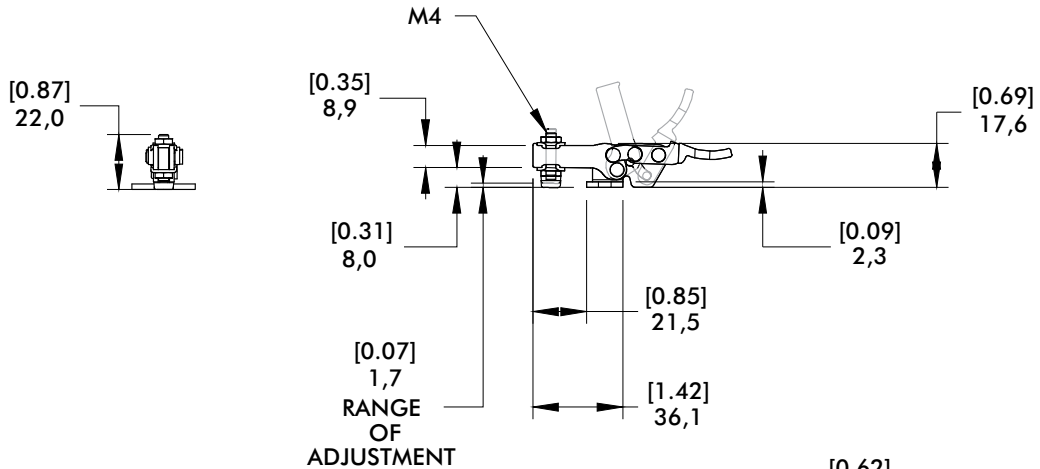
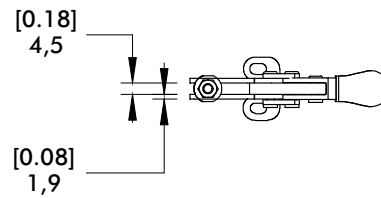

2005-S
Solid Bar

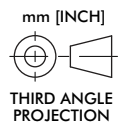
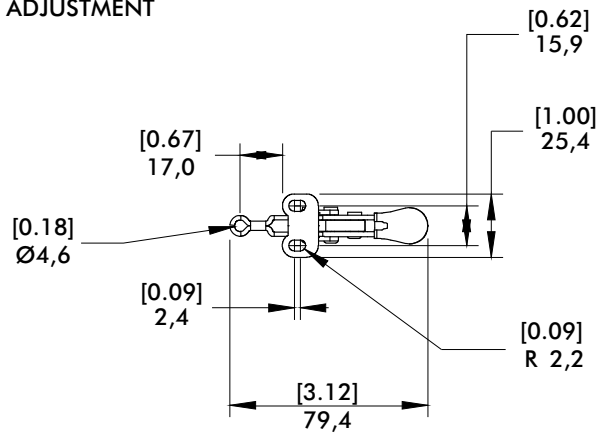

Courtesy of CMA/Flodyne/Hydradyne • Motion Control • Hydraulic • Pneumatic • Electrical • Mechanical • (800) 426-5480 • www.cmaf.h.com