

Lateral Plungers - smooth, with seal, with female thread - INCH

2B150.1120



Product Description

To be used for positioning and applying pressure, e.g. during painting and sandblasting. Sealed against chips and dirt.

Material

Seal

- CR

Body

- Aluminium

Threaded washer

- Steel, blackened

Spring

- Stainless steel

Assembly

Formula for calculating the center distance for the mounting hole:

$$l_0 = z/2 + w + x,$$

l_0 = center distance,

y = workpiece height,

w = workpiece length,

x = stroke,

z = stop diameter

Calculation dimension x for workpieces: $x =$

$$d_2/2 - s$$

Installation by pressing in.

Characteristic

Light spring load = spring from stainless steel

More information

Notes

Individual set screws can be screwed in the plate with threaded hole.

Further products

- Eccentric Mounting Bushings, for lateral plungers, smooth - INCH

Drawing

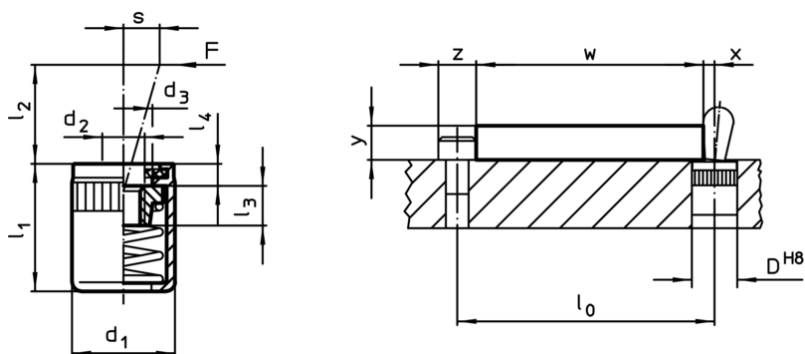

Order information

Dimensions		Spring load F max. ¹⁾ [lb]	d ₃ +0,008 [mm]	l ₁ -0,04	Dimensions			Stroke s [inch]	Location hole D H8 [inch]	max. [°F]	oz	Art. No.
d ₁	d ₂				l ₂	l ₃	l ₄					
[inch]	[inch]				[inch]							
7/16	8-32	4,5	0,248	0,43	0,1	0,177	0,063	0,063	7/16	230	0,082	2B150.1120

¹⁾ statistical average value

Accessories

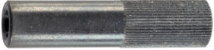
	Dimensions d ₁ [inch]	 [oz]	Art. No.
assembly tool			
	7/16	1,749	22150.0831