

## Lateral Plungers· smooth, without seal, with female thread - INCH

2B150.1041



### Product Description

To be used for positioning and applying pressure, e.g. during painting and sandblasting.

#### Material

##### Body

- Aluminium

##### Threaded washer

- Steel, blackened

##### Spring

- Steel, blackened

#### Assembly

Formula for calculating the center distance for the mounting hole:

$$l_0 = z/2 + w + x,$$

$l_0$  = center distance,

$y$  = workpiece height,

$w$  = workpiece length,

$x$  = stroke,

$z$  = stop diameter

Calculation dimension  $x$  for workpieces:  $x = d_2/2 - s$

Installation by pressing in.

#### Characteristic

Standard spring load = spring from steel, blackened

#### More information

#### Notes

Individual set screws can be screwed in the plate with threaded hole.

#### Further products

- Eccentric Mounting Bushings, for lateral plungers, smooth - INCH

### Drawing

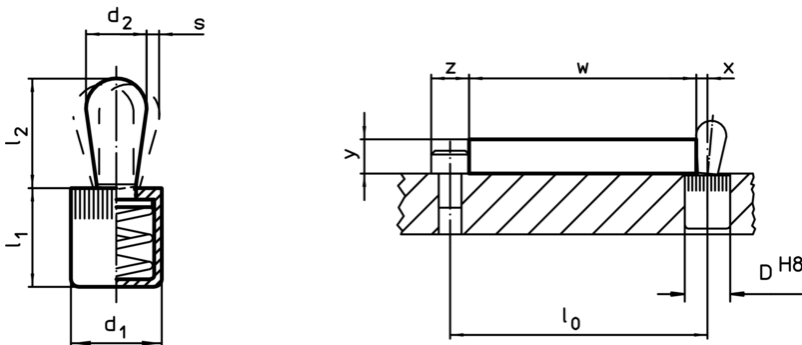



### Order information

Dimensions		Spring load F max. <sup>1)</sup> ~ [lb]	d <sub>3</sub> +0,008	l <sub>1</sub> -0,04	Dimensions			Stroke s [inch]	Location hole D H8 [inch]	max. [°F]	oz	Art. No.
d <sub>1</sub> [inch]	d <sub>2</sub> [inch]				l <sub>2</sub> [inch]	l <sub>3</sub> [inch]	l <sub>4</sub> [inch]					
5/8	1/4-20	34	0,409	0,669	0,453	0,295	0,067	0,126	5/8	482	0,321	2B150.1041

<sup>1)</sup> statistical average value

Accessories

	Dimensions d <sub>1</sub> [inch]	 [oz]	Art. No.
assembly tool			
	5/8	3,749	22150.0833