

Lateral Plungers with plastic spring and pin - INCH

2B150.0326



Product Description

To be used for positioning and applying pressure, e.g. during painting and sandblasting.

Material

- Body**
- Aluminium
- Spring**
- Plastic
- Pin**
- Stainless steel

Assembly

Installation by pressing in.
Formula for calculating the center distance for the mounting hole:
 $l_0 = z/2 + w + x$,
 l_0 = center distance,
 y = workpiece height,
 w = workpiece length,
 x = coordinate dimension,
 s = stroke,
 z = stop diameter
Calculation dimension x :
 y greater than or equal to $l_2 - d_2/2$, then $x = d_2/2 - s$
or
 y smaller than $l_2 - d_2/2$, then $x = d_2/2 - s - [(l_2 - d_2/2 - y) * 0,123]$

Characteristic

Standard spring load = red spring

Drawing

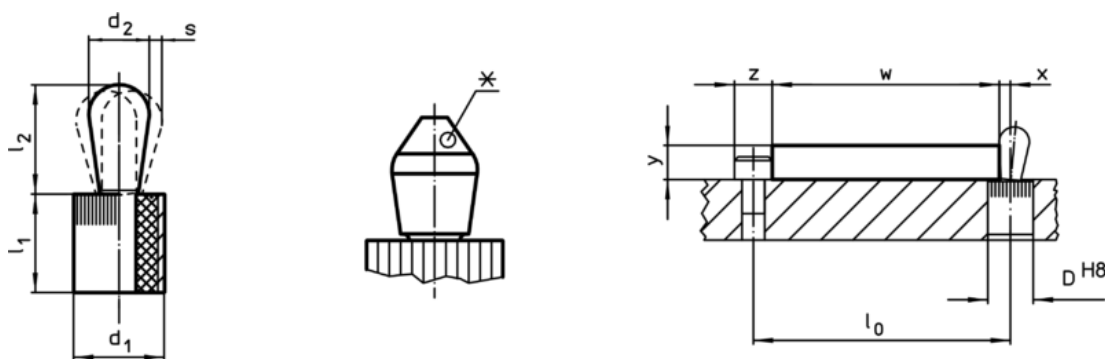

*some sizes (see chart) have a deviating pin shape

Order information

Dimensions		Spring load F max. ¹⁾ ~ [lb]	Dimensions		Stroke s [inch]	Location hole D H8 [inch]	max. [°F]	oz	Art. No.
d ₁ [inch]	d ₂ [inch]		l ₁ -0,03 [inch]	l ₂ ±0,02 [inch]					
7/16	0,236	6,7	0,374	0,406	0,04	0,438	212	0,124	2B150.0326

¹⁾ statistical average value

Accessories

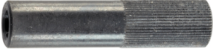
	Dimensions d ₁ [inch]	 [oz]	Art. No.
assembly tool			
	7/16	1,749	22150.0831