

## Lateral Plungers with plastic spring and pin - INCH

### 2B150.0226



#### Product Description

To be used for positioning and applying pressure, e.g. during painting and sandblasting.

#### Material

##### Body

- Aluminium

##### Spring

- Plastic

##### Pin

- Steel, case-hardened, blackened

#### Assembly

Installation by pressing in.

Formula for calculating the center distance for the mounting hole:

$$l_0 = z/2 + w + x,$$

$l_0$  = center distance,

$y$  = workpiece height,

$w$  = workpiece length,

$x$  = coordinate dimension,

$s$  = stroke,

$z$  = stop diameter

Calculation dimension  $x$ :

$y$  greater than or equal to  $l_2 - d_2/2$ , then  $x =$

$$d_2/2 - s$$

or

$y$  smaller than  $l_2 - d_2/2$ , then  $x =$

$$d_2/2 - s - [(l_2 - d_2/2 - y) * 0,123]$$

#### Characteristic

Standard spring load = red spring

#### Drawing

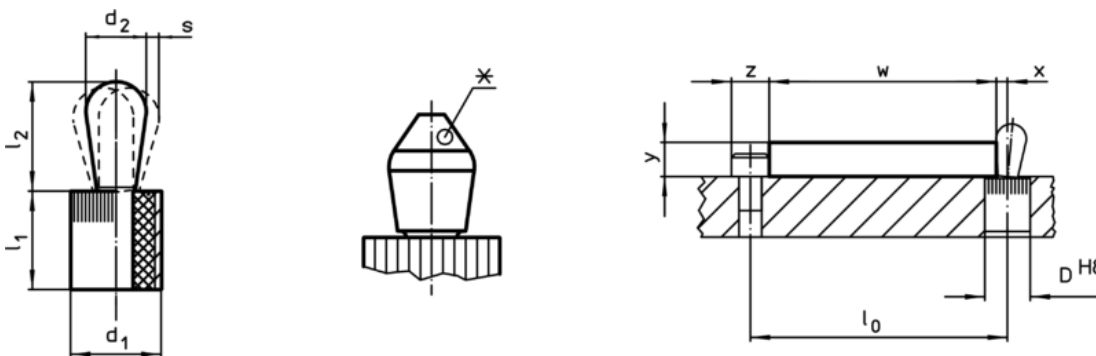

\*some sizes (see chart) have a deviating pin shape

#### Order information

Dimensions		Spring load F max. <sup>1)</sup> ~ [lb]	Dimensions		Stroke s [inch]	Location hole D H8 [inch]	max. [°F]	oz	Art. No.
d <sub>1</sub> [inch]	d <sub>2</sub> [inch]		l <sub>1</sub> -0,03 [inch]	l <sub>2</sub> ±0,02 [inch]					
7/16	0,236	6,7	0,374	0,406	0,04	0,438	212	0,121	2B150.0226

<sup>1)</sup> statistical average value

Accessories

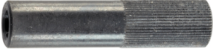
	Dimensions d <sub>1</sub> [inch]	 [oz]	Art. No.
assembly tool			
	7/16	1,749	22150.0831