

Tapered Shaft Hubs with lock nut

25050.0125

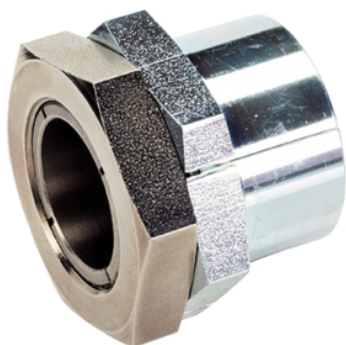

Product Description

It is a self-centering and non-floating tapered shaft hub in corrosion-protected design with a hexagon nut and a lock nut.

The rotational accuracy is 0,03 mm.

By using tapered shaft hubs, all shaft-hub joints of machine elements such as sprocket wheels, gear wheels, belt pulleys, cams, levers etc. can be easily and efficiently established.

Material

External part

- Steel, zinc-plated by galvanization

Inner part

- Steel, nickel-plated

Nut

- Steel, nickel-plated

Assembly

The lock nut at the outer part facilitates locking of the shaft-hub joint if freely rotating shafts are involved. For mounting, a crescent wrench (thickness max. l_2-l_3) is used.

More information

References

Mounting instructions, mounting arrangements and technical data will be found on the following pages.

Drawing

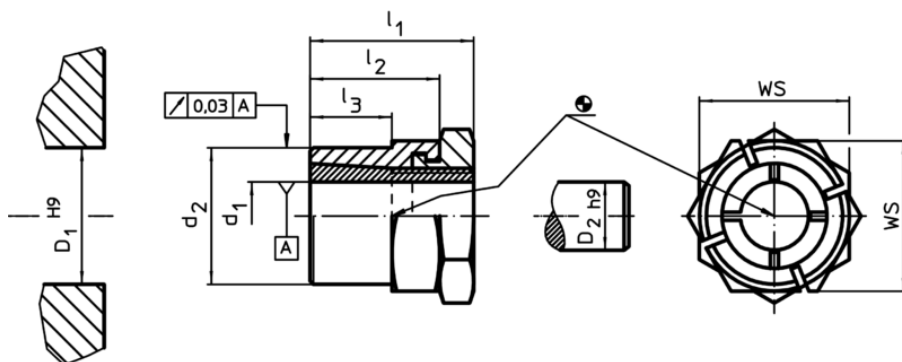

Order information

Dimensions					WS [mm]	Tightening torque of the nut T_A max. [Nm]	Transferable torque M max. [Nm]	Transferable thrust load F_a max. [kN]	Surface pressure shaft p_w max. [N/mm ²]	Surface pressure hub p_n max. [N/mm ²]	Hub bore D_1 H9 [mm]	Shaft diameter D_2 h9 [mm]	[g]	Art. No.
d_1	d_2	l_1	l_2	l_3										
25	38	41	30	20	46	250	397	31,8	173	122	38	25	310	25050.0125

Accessories

WS [mm]	[g]	Art. No.
special fork wrench		
46	612	25050.0846

Application example

