

Tapered Shaft Hubs• no lock nut

25050.0009



Product Description

By using tapered shaft hubs, all shaft-hub joints of machine elements such as sprocket wheels, gear wheels, belt pulleys, cams, levers etc. can be easily and efficiently established. It is a self-centering and non-floating tapered shaft hub in corrosion-protected design with a hexagon nut. The rotational accuracy is 0,03 mm.

Material

External part

- Steel, zinc-plated by galvanization

Inner part

- Steel, nickel-plated

Nut

- Steel, nickel-plated

More information

References

Mounting instructions, mounting arrangements and technical data will be found on the following pages.

Drawing

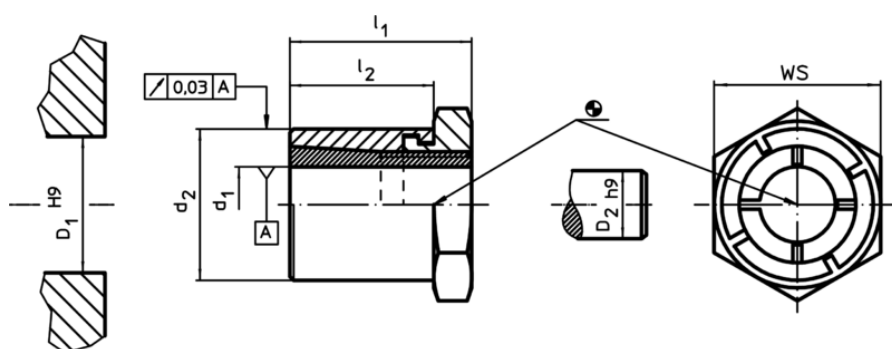

Order information

Dimensions				WS	Tightening torque of the nut T_A max.	Transferable torque M max.	Transferable thrust load F_a max.	Surface pressure shaft p_w max.	Surface pressure hub p_N max.	Hub bore D_1 H9	Shaft diameter D_2 h9	Art. No.	
d_1	d_2	l_1	l_2										
[mm]				[mm]	[Nm]	[Nm]	[kN]	[N/mm ²]	[N/mm ²]	[mm]	[mm]	[g]	
9	20	24	19	22	34,9	43,7	9,7	245	115	20	9	47	25050.0009

Accessories

WS	Art. No.
[mm]	[g]
special fork wrench	
22	115
	25050.0822

Application example

