

Palm Grips with axial bearing
24700.0063



Product Description

Advantages of axial bearing:

- Double clamping force with same grip size, by reducing the surface friction.
- Protection of workpiece by a fixed locating surface.
- Little setting due to higher pre-clamping force of bolt resp. thread.

Material

Handle

- Thermoplastic PA

Inner part

- Steel, nitrided, blackened

Drawing

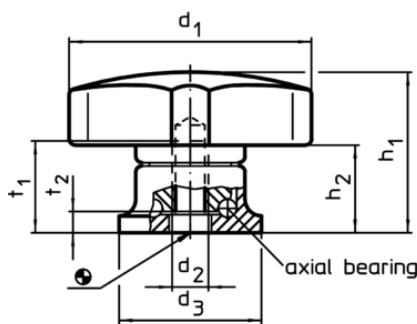

picture 1

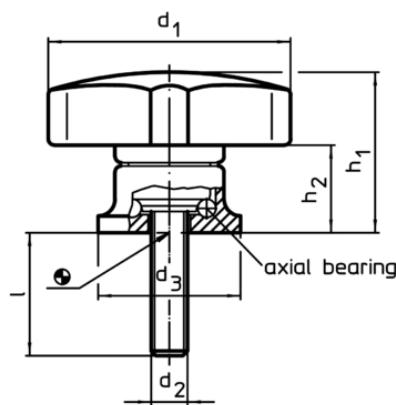

picture 2

Order information

Dimensions							max. [°C]	[g]	Art. No.
d ₁	d ₂	d ₃	h ₁ ~ [mm]	h ₂ ~	t ₁ min.	t ₂			
with female thread – picture 1									
63	M10	30	41	26,5	18	5,4	80	111	24700.0063

Application example

